

Democratic and Popular Republic of Algeria  
Ministry of Higher Education and Scientific Research

**M'HAMED BOUGARA UNIVERSITY - BOUMERDÈS**



Faculty of Technology  
Department of Electrical Systems Engineering

Course:  
**Power Electronics**

Third Year Bachelor's Degree in Electrotechnics

Prepared by: **Dr. Aimad BOUDOUDA**  
Associate Professor

# Contents

Introduction.....	1
-------------------	---

## CHAPTER 1

### Introduction to power electronics

1. Introduction.....	2
2. Classification of power electronics.....	3
3. Power semiconductor switches used in power electronics.....	4
3.1 Static V-I characteristics of semiconductors .....	4
3.2 Classifications of power semiconductor devices.....	4
3.3 Dynamic characteristic (Switching Modes).....	9
3.4 Losses in semiconductor components .....	10
4. Combining semiconductor components .....	11
5. Limits and applications of power semiconductors.....	12

## CHAPTER 2

### AC-DC conversion (Rectifiers)

1. Introduction.....	14
2. Basic definitions .....	14
2.1 Mean value.....	14
2.2 Root mean square value (RMS).....	14
2.3 Form factor.....	15
2.4 Ripple Factor.....	15
2.5 Distortion factor of a rectifier (DF).....	15
2.6 Displacement factor of a rectifier (DPF).....	16
2.7 Power factor of rectifier (PF).....	16
3. Uncontrolled rectifiers (Using diodes).....	16
3.1 Single-phase half-wave rectifier.....	16
3.2 Single-phase full-wave rectifier .....	20
3.3 Three-phase half-wave rectifier .....	22
3.4 Three-phase full-wave rectifier.....	23
4. Controlled rectifiers (Using Thyristors).....	25
4.1 Single-phase half-wave rectifier.....	25
4.2 Single-phase full-wave rectifier .....	28
4.3 Three-phase half-wave rectifier .....	30
4.4 Three-phase full-wave rectifier.....	32
5. Problems.....	34

**CHAPTER 3****AC-AC conversion (Dimmer)**

1. Introduction.....	43
2. Single-phase AC voltage controller.....	43
3. Cyclo-converters.....	46

**CHAPTER 4****DC-DC conversion (Choppers)**

1. Introduction.....	49
2. Buck converter .....	50
3. Boost converter.....	52
4. Buck-Boost converter .....	53
5. Problems.....	55

**CHAPTER 5****DC-AC conversion (Inverters)**

1. Introduction.....	60
2. Single-phase voltage inverters.....	61
2.1 Half-Bridge single-phase inverter.....	61
2.2 Single-phase Full-Bridge inverter.....	62
2.3 Different types of control for the single-phase inverter.....	62
a) Symmetrical control (full wave).....	62
b) Phase-shifted control.....	63
c) Pulse width modulation (PWM) control.....	64
3. Three-phase voltage inverters.....	67
a) Symmetrical control (full wave).....	68
b) Pulse width modulation (PWM) control.....	69
4. Problems.....	69
Appendix.....	72
References .....	77

## Introduction

This document serves as a course material for power electronics primarily intended for third-year Bachelor's students specializing in Electrotechnics within the Department of Electrical Systems Engineering. It serves as a guiding resource for understanding the fundamentals and essential concepts of power electronics. The document assumes that the students are already familiar with general circuit analysis techniques usually taught at the S3 semester. While a basic understanding of electronic devices like diodes and transistors is expected, the primary focus of this document lies in circuit topology and functionality rather than individual devices.

It is important to note that this work is not final and its writing is provisional; it does not claim to be exhaustive.

The document is organized into five chapters, aligning with the official power electronics program of the third year of the Bachelor's degree in Electrotechnics. Some chapters are accompanied by practical exercises.

The first chapter delves into the static and dynamic characteristics of components commonly used in power electronics.

The second chapter is dedicated to the study of the main types of AC/DC converters, encompassing both single-phase and three-phase rectifiers, in both controlled and uncontrolled configurations.

The third chapter is dedicated to the study of AC/AC converters, including single-phase AC voltage controller and cyclo-converters.

The fourth chapter focuses on the primary types of DC/DC converters, commonly known as choppers.

The fifth chapter is devoted to the exploration of DC/AC converters, covering single-phase and three-phase inverters.

These chapters are complemented by an appendix that provides essential mathematical tools.

**Teaching objectives:** By the end of this course, students should be able to:

- Recognize the various types of converters.
- Understand the components used in power electronics.
- Master the operation of key static converters.
- List the different power switches and comprehend their characteristics and modes of operation.

# Chapter 1

## Introduction to power electronics

### 1. Introduction

Power electronics or switching electronics: a field of Electrical Engineering that deals with the application of power semiconductor devices for the control and conversion of electric power.

The goals of power electronics:

- To process and control the transfer of electrical energy between a source and a load. To achieve this, semiconductors are used as switches responsible for adapting the voltages and currents from a distribution network to meet the requirements of the load to be powered.
- To enhance energy efficiency by reducing energy losses during the conversion process. This leads to more sustainable and environmentally friendly energy usage, making power electronics crucial in addressing today's energy challenges.

As shown in Figure 1.1, power electronics represents a median point at which the topics of energy systems, electronics, and control converge. Any useful circuit design for the control of power must address issues of both devices and control, as well as of the energy itself. Among the unique aspects of power electronics are its emphasis on large semiconductor devices, the application of magnetic devices for energy storage.

The development of semiconductor switches manufacturing regarding their very high ratings and their ability in high frequency systems are the basic keys in the development of power electronics engineering.

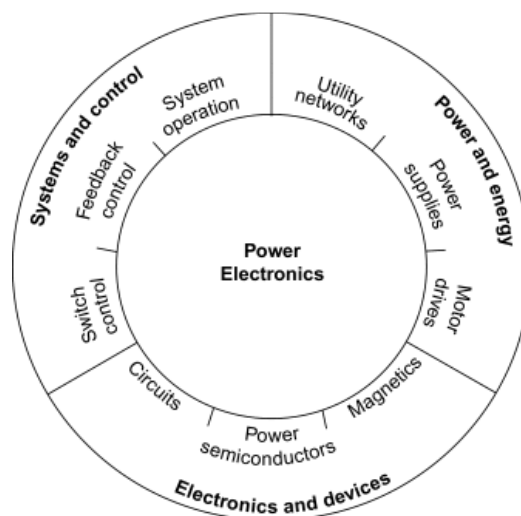

**Fig.1.1** Control, energy, and power electronics are interrelated

A basic power electronic system is shown in Figure 1.2. It consists of an energy source, an electrical load, a power electronic circuit, and control circuit. The function of the power electronic positioned at the middle is that of controlling energy flow between the energy source and the electrical load. The power electronic circuit contains high power switches, lossless energy storage elements, and magnetic transformers. The control circuit takes information from the source, load, and designer and then determines how the switches operate to achieve the desired conversion. The control circuit is usually built up with conventional low-power analog and digital electronics.

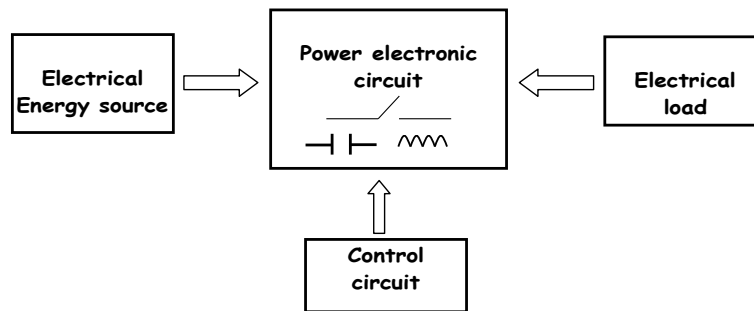
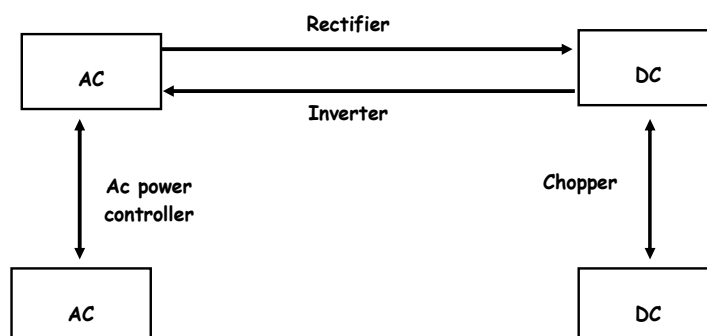

**Fig.1.2** A basic power electronic system

## 2. Classification of power electronics

The following graph shows the various conversion modes that exist depending on the nature of the electrical energy sources. In power electronics, there are four possible conversions and converters:

- AC to DC converters – rectifiers that transform AC to DC with adjustment of voltage and current  
Applications: Battery chargers, High voltage dc (HVDC) transmission line.
- AC to AC converters – AC frequency, phase, magnitude, and power converters, both with and without an intermediary DC link  
Applications: Fun regulator, lighting system for theatres.
- DC to DC converters – linear regulators and switching choppers  
Applications: Robots, DC motor speed control.
- DC to AC converters – inverters that produce AC of controllable magnitude and frequency  
Applications: Photovoltaic cell, UPS (uninterruptible power supplies). AC motor speed control



### 3. Power semiconductor switches used in power electronics

#### 3.1. Static V-I characteristics of semiconductors

A switch is defined by its two stable states in static mode (Fig.1.3a):

- Conducting state (ON state);  $v_k = 0, i_k \neq 0$
- Blocking state (OFF state);  $v_k \neq 0, i_k = 0$

The V-I characteristic provides the operating region of a switch. It consists of different segments on the axes of the coordinate system ( $v_k, i_k$ ). Thus, one can consider switches with 2, 3, or 4 segments that will be adapted to the nature and reversibility of the sources and loads. Note that for an ideal switch, the static characteristic is non-dissipative.

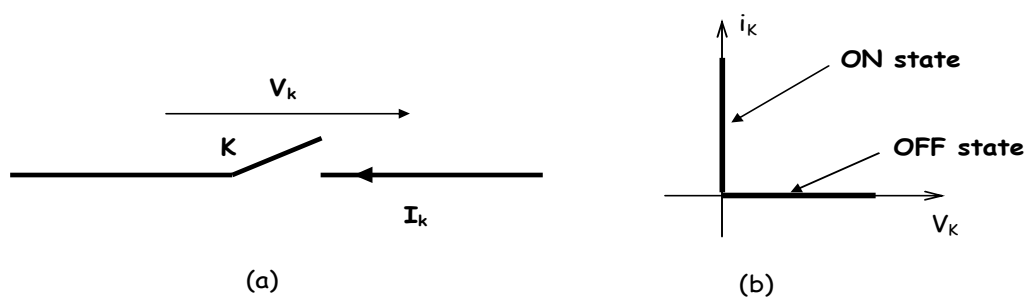

**Fig.1.3** Symbol of a switch and its static characteristic

It is always desirable to have power switches perform as close as possible to the ideal case. Semiconductors, when operating as ideal switches, should exhibit the following characteristics:

- No limit on the amount of current (referred to as forward or reverse current) the device can carry when in the conduction state (on-state).
- No limit on the amount of device voltage (known as forward or reverse blocking voltage) when the device is in the non-conduction state (off-state).
- Zero on-state voltage drop when in the conduction state.
- Infinite off-state resistance, meaning zero leakage current when in the non-conduction state.
- No limit on the operating speed of the device when changing states, i.e., zero rise and fall times.

#### 3.2. Classifications of power semiconductor devices

- **Uncontrolled switch:** The switch has no control terminal. The state of the switch is determined by the external voltage or current conditions of the circuit in which the switch is connected. A diode is an example of such switch.
- **Semi-controlled switch:** In this case the circuit designer has limited control over the switch. For example, the switch can be turned-on from the control terminal. However, once ON, it cannot be

turned-off from the control signal. The switch can be switched off by the operation of the circuit or by an auxiliary circuit that is added to force the switch to turn-off. A thyristor or a SCR is an example of this switch type.

- **Fully controlled switch:** The switch can be turned ON and OFF via the control terminal. Examples of this switch are the BJT, the MOSFET, the IGBT, the GTO thyristor, and the MOS-controlled thyristor (MCT)

**Power diode:** Among all the static switching devices used in power electronics, the power diode is perhaps the simplest. Its circuit symbol shown in Figure 1.4 (a) is a two-terminal device involves the anode terminal (A) and the cathode terminal (K). It is a non-controllable component; its behavior is determined by the circuit in which it is placed.

If anode terminal is at a higher potential compared to cathode terminal, the device is said to be forward biased and a forward current will flow through the device. This causes a small voltage drop across the device ( $<1$  V), which under ideal conditions is usually ignored. However, when cathode terminal is at a higher potential compared to anode terminal, the diode is reverse biased. It does not conduct, and the diode then experiences a small current flowing in the reverse direction called the leakage current. This current is dependent on the reverse voltage until the breakdown voltage is reached. After that, the diode voltage remains essentially constant while the current increases dramatically.

Only the resistance of the circuit limits the maximum value of the current. Simultaneous large current and large voltage in the breakdown operation leads to excessive power dissipation that could quickly destroy the diode. Therefore, the breakdown operation of the diode must be avoided. Figure 1.4(c) illustrates diode characteristics where breakdown voltage is shown.

Both forward voltage drop and leakage current are ignored in an ideal diode. In power electronic applications, a diode is usually considered to be an ideal static switch, Figure 1.4 (b).

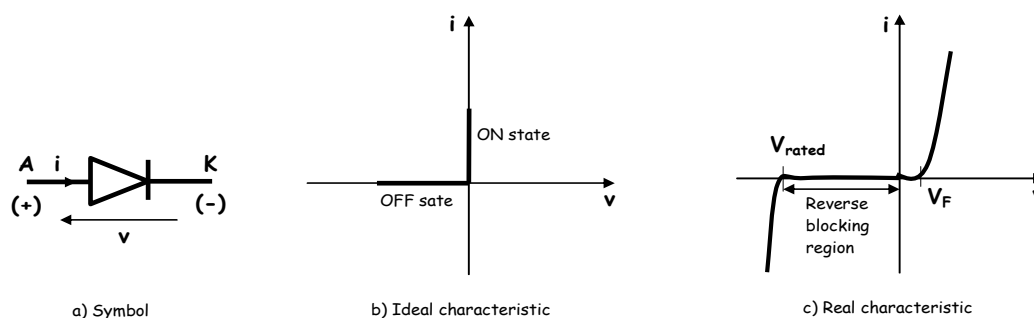

**Fig.1.4** The diode

When:

$V \geq 0$  and  $i > 0$ , the diode is conducting (closed).

$V < 0$  and  $i < 0$ , the diode is blocking (open).

The diode is unidirectional in voltage and current (a two-segment switch).



**Thyristor:**

Thyristors known as Silicon-controlled rectifiers (SCR) are usually three-terminal devices. The control terminal of the thyristor, called the gate (G) electrode, which allows it to become conductive when the voltage  $V_{th}$  across its terminals is positive. It is a semi-controllable component. The other two terminals, anode (A) and cathode (K) handle the large applied potentials (often of both polarities) and conduct the major current through the thyristor. Thyristors are capable of handling large blocking voltages and large currents for use in high-power applications, but their frequency capabilities are not very high, being lower than 10 kHz.

If positive voltage is applied without gate current, the thyristor constitutes the state of forward blocking. A low-power pulse of gate current switches the thyristor to the ON state. The output characteristic of a conducting thyristor in the forward bias is similar to the characteristic of the diode with a small leakage current. Thus, the thyristor assumes very low resistance in the forward direction. Once turned ON, the thyristor remains in this state after the end of the gate pulse if its current is higher than the latching value. If the current drops below the holding value, the device switches back to the non-conducting region. Switching off by gate pulse is impossible. Therefore, using the same arguments as for diodes, the thyristor can be represented by the idealized switch.

The output characteristic of SCR in the reverse bias is similar to the characteristic of the diode with a small leakage current. With negative voltage between anode and cathode, this corresponds to the reverse blocking state. If the maximum reverse voltage exceeds the permissible value, the leakage current rises rapidly, as with diodes, leading to breakdown and thermal destruction of the thyristor. Figure 1.5 (a), (b) and (c) illustrate the SCR symbol, its ideal characteristic and its practical characteristic, respectively.

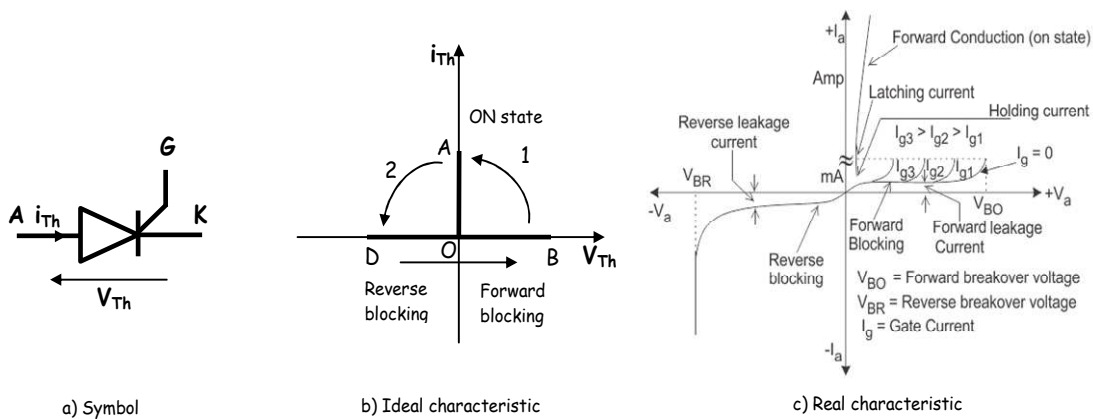

**Fig.1.5** The thyristor

It can be inferred from the static V-I characteristic that the SCR consists of three segments (three modes of operation):

OD, reverse blocking mode: Thyristor is blocked, with low reverse leakage current.

OB, forward blocking mode (no gate pulse since  $V_{Th}$  became positive): Thyristor is blocked, with low forward leakage current.

OA, forward conduction mode: Thyristor is conducting, low forward voltage drop, and the forward current is determined by the circuit in which the thyristor is inserted.

When:

$$V_{Th} \geq 0:$$

If  $i_{Th} = 0$  and  $i_G = 0$  : the thyristor is blocked (can be triggered).

If  $i_G > 0$  : the thyristor is conducting (1).

$V_{Th} < 0$  and  $i_{Th} = 0$  : the thyristor is blocked (2).

### GTO Thyristor (Gate Turn-Off Thyristor):

GTO is a special type of thyristor, which provides more control. As opposed to normal thyristors, GTOs are fully controllable switches which can be turned ON and OFF by switching the polarity of the gate signal.

The GTO thyristor turns ON similarly to the SCR thyristor, i.e. after a current pulse is applied to the gate terminal. To turn it OFF, a powerful negative current control pulse must be applied to the gate terminal.

GTO thyristors are typically employed in high-power or very high-power converters where precise control of the switching process is necessary.

Figure 1.6 (a) and (b) illustrate the GTO symbol and its ideal characteristic, respectively.

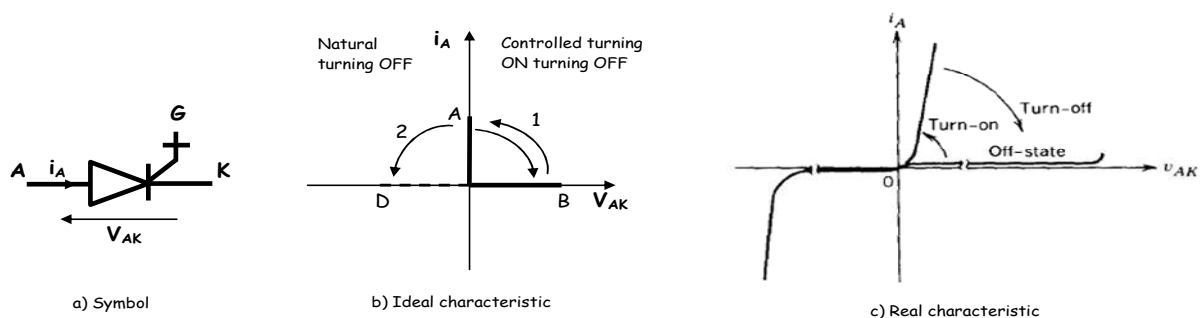

**Fig.1.6** The GTO thyristor

When:

$V_{AK} < 0$  and  $i_A = 0$ : The GTO thyristor is blocked (2).

$V_{AK} > 0$  and  $i_A > 0$  and  $i_G \neq 0$ : The GTO thyristor is conducting (1).

When  $V_{AK} > 0$  and  $i_A > 0$ , the GTO thyristor can be blocked by a negative gate current pulse (1). It can also spontaneously block (like a diode) when  $i_A = 0$  (2).

### Power transistor:

Power transistors are three-terminal semiconductor electronic devices that can be used as switches. Transistors are turned ON when a current or voltage signal is applied to the control terminal. The transistor remains in the ON-state so long as control signal is present. When this control signal is removed, the power transistor is turned OFF. The switching speed of modern transistors is much higher than that of thyristors. In addition, the control circuit is much simpler than that used in thyristors. In power electronics, there are three types of power transistors:

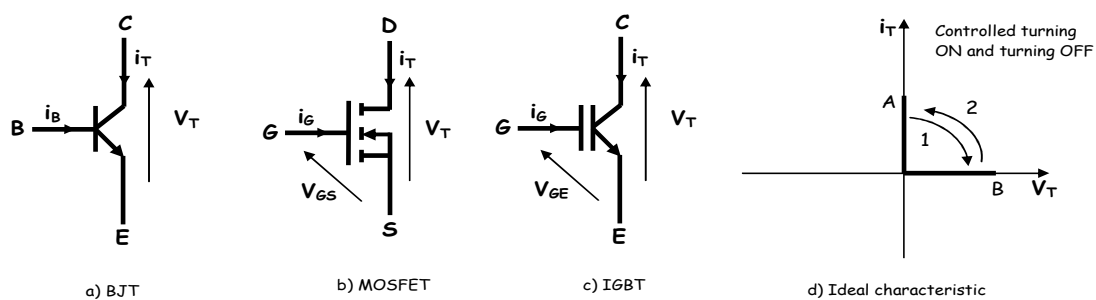

**Fig.1.7** The power transistor

-The Bipolar Junction Transistor (BJT) is controlled by the current  $i_B$ :

$i_B = 0$ : The BJT is blocked (1).

$i_B > 0$ : The BJT is conducting (2).

It can be controlled for both turning on and turning off.

-The Metal-Oxide-Semiconductor Field-Effect Transistor (MOSFET) is controlled by voltage  $V_{GS}$ :

$V_{GS} = 0$ : The MOSFET is blocked (1).

$V_{GS} > 0$ : The MOSFET is conducting (2).

It can be controlled for both turning on and turning off, and it operates at very high switching frequencies.

-The Insulated Gate Bipolar Transistor (IGBT) combines characteristics of both BJT and MOSFET. It is controlled by voltage  $V_{GE}$ .

**3.3 Dynamic characteristic (Switching Modes):**

The static characteristic of a switch is insufficient to describe its dynamic properties, meaning how the switch transitions from the blocking state to the conducting state, or vice versa. The dynamic switching characteristic is the path followed by the operating point during the switch's transition, moving from one half-axis to another perpendicular half-axis. This trajectory can only occur in quadrants where  $i_k, v_k > 0$  since the switch is considered a dissipative element.

During turn-on and turn-off processes, two modes of switch state changes can be distinguished: spontaneous switching and controlled switching.

**3.3.1 Spontaneous switching (Natural):** This is the type of switching carried out by a diode. The transition from the conducting state to the blocking state can only occur at zero current and from the blocking state to the conducting state at zero voltage. The change in state is induced by the environment in which the switch is located.

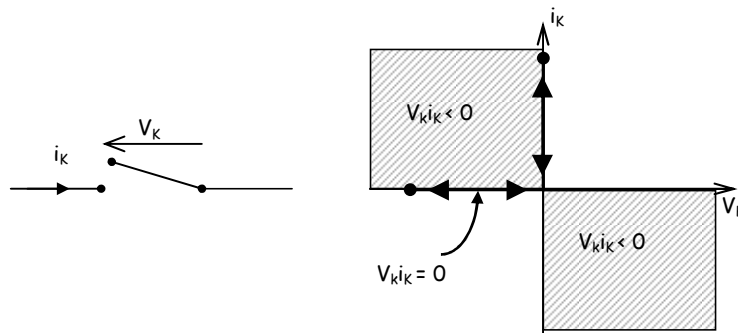

**Fig.1.8** Spontaneous switching (Turn-On and Turn-Off)

State transitions occur along the axes, thus without energy losses, which are referred to as switching losses.

**3.3.2 Controlled switching (Forced):** This is the type of switching carried out by a transistor or thyristor (or any other controlled component). The transition from the conducting state to the blocking state (or vice versa) occurs in response to an external command or control signal.

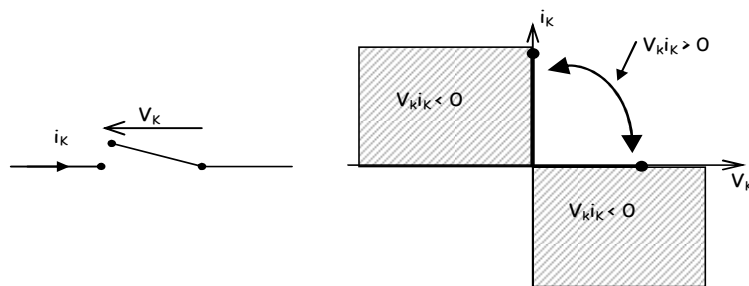
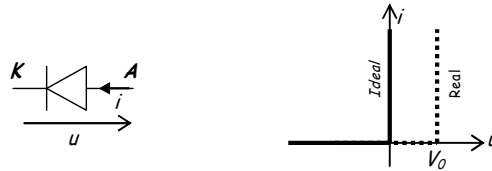

**Fig.1.9** Controlled switching (Turn-On and Turn-Off)

The change in state occurs by crossing the  $V_K i_K > 0$  plane. Therefore, the switch experiences switching losses (the switch is dissipative).

**3.4 Losses in semiconductor components:**

A non-ideal semiconductor component from a dynamic perspective (real) exhibits Joule losses during both the opening and closing processes.



**Fig.1.10** Real characteristic of a switch

In reality, for a real switch, there is a small positive voltage drop ( $V_0$ ) when it becomes conducting. The switching occurs in a non-spontaneous manner from one state to another. In this case, the switch dissipates energy during each switching cycle and is therefore subject to switching losses.

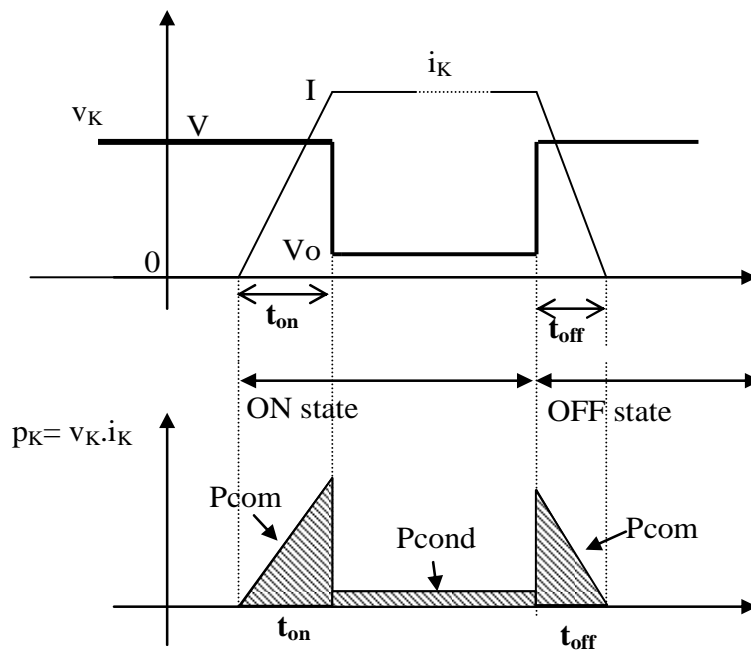

**Fig.1.11** Switching losses in a switch

$t_{on}$  = rise time of  $I_K$  during closing;

$t_{off}$  = fall time of  $I_K$  during opening;

$T$  = switching period.

The power dissipated due to switching losses is calculated as:  $P_{com} = \frac{VI}{T} \left( \frac{t_{on} + t_{off}}{2} \right)$

Switching losses limit the frequency of use for components.

**4. Combining semiconductor components**

To achieve performance characteristics different from those of the three basic switches (diode, thyristor, transistor), multiple basic components are sometimes combined.

-Reversible voltage switches: By adding a diode in series with a GTO thyristor or a transistor, a voltage-reversible switch with controlled closing and opening can be obtained.

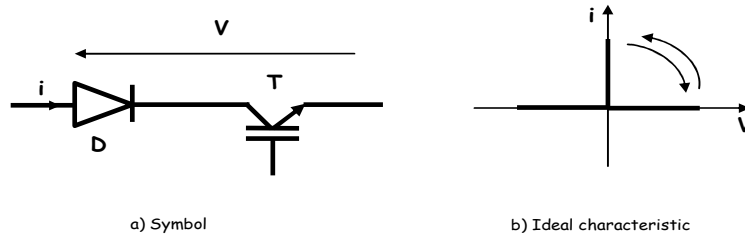

**Fig.1.12** Bidirectional voltage switch

-Bidirectional current switches: These are achieved by adding two semiconductor devices connected in parallel with reverse polarity.

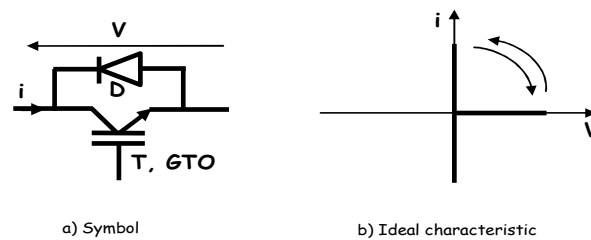

**Fig.1.13** Bidirectional current switch

-Bidirectional voltage and current switches: These are obtained either by placing two bidirectional current switches in series or by connecting two bidirectional voltage switches in parallel.

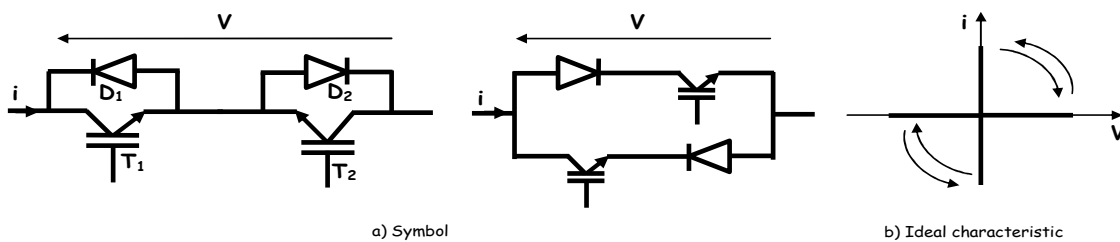

**Fig.1.14** Bidirectional voltage and current switch

A bidirectional switch that is reversible in both voltage and current, with only the turn-on events being controlled, can be obtained by connecting two symmetrical thyristors in anti-parallel (Figure 1.15).

In low-power applications, the two thyristors can be replaced by a single component, the triac, which has a single gate for triggering in both directions.

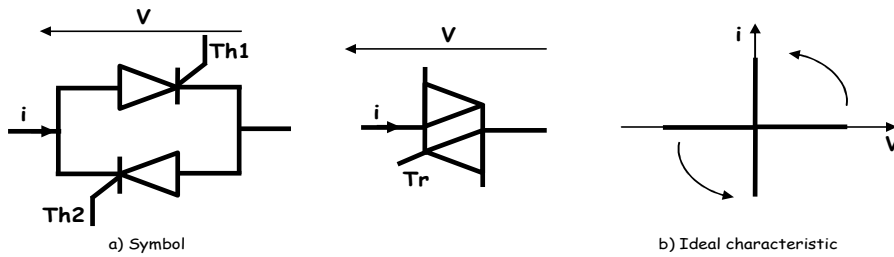
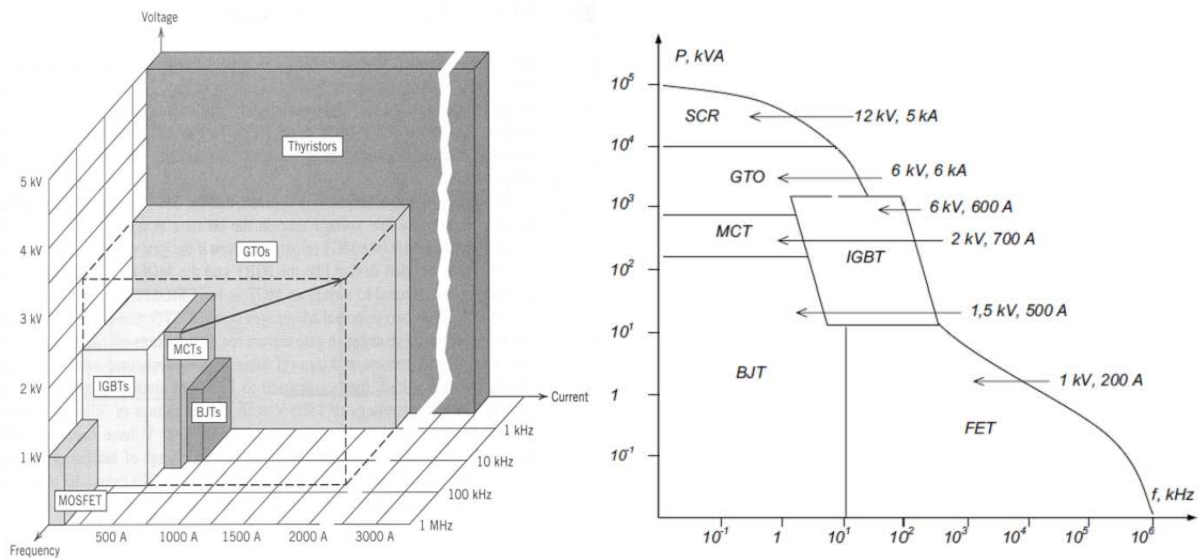

**Fig.1.15** Bidirectional current and voltage switch (Triac)

**5. Limits and applications of power semiconductors**

To give an idea of the application ranges of power semiconductors, they have been plotted on Figure 1.16 in the power breaking capacity/frequency plane.

The usage ranges extend from tens of Hertz for applications operating at the mains frequency to several hundred kilohertz for applications using the fastest MOS transistors. Similarly, it can be observed that the power range spans from a few VA (Volt-Amperes) to several hundred MVA (Mega-Volt-Amperes) for the most powerful applications.



**Fig.1.16** Zones of power ratings and switching speeds of power semiconductors

It's astonishing to realize that there is hardly a home, office block, factor, car, sport hall, hospital or theatre without an application, and sometimes many applications of power electronic equipment as cleared in Figure 1.17.

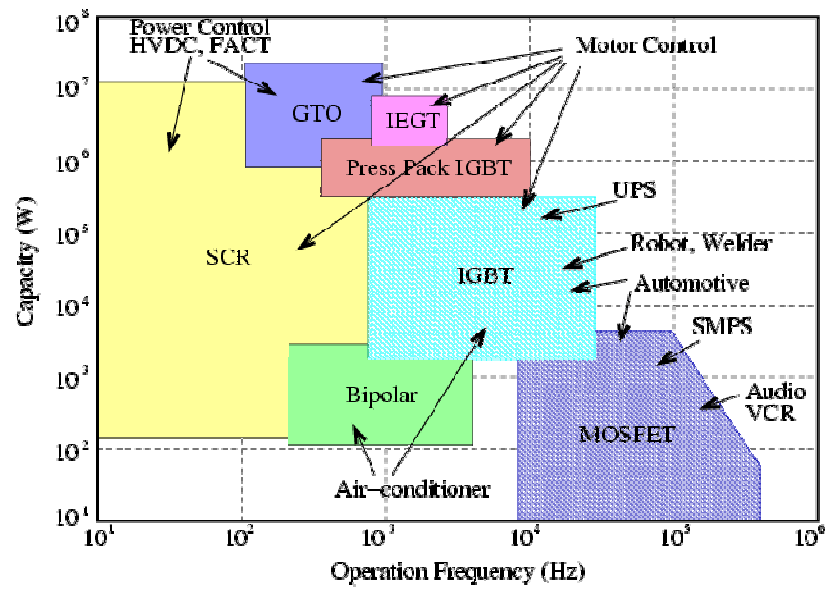

Fig.1.17 Some applications of power semiconductors



## Chapter 2

### AC-DC conversion (Rectifiers)

#### 1. Introduction

Rectifier circuits are power electronic converters that perform the conversion of alternating current (AC) into direct current (DC). When supplied with a single-phase or three-phase AC voltage source, they provide DC current to the load connected at their output.

Rectifiers are employed whenever there is a need for direct current while the electrical energy source is in alternating current form. Rectifiers find application in a wide range of areas due to their versatility and capability to convert AC to DC power effectively.

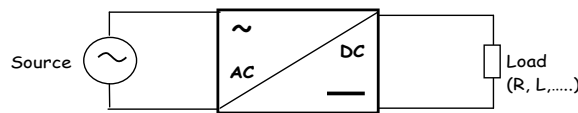

**Fig.2.1** AC-DC conversion

Diode rectifiers, or uncontrolled rectifiers, do not allow for varying the ratio between the input alternating voltage and the output direct voltage. Furthermore, they are irreversible, meaning that power can only flow from the alternating side to the direct side.

Thyristor rectifiers, or controlled rectifiers, allow, for a fixed input alternating voltage, to vary the output direct voltage. Additionally, they are reversible; when they transfer power from the direct side to the alternating side, they are referred to as non-autonomous inverters.

#### 2. Basic definitions:

Certain terms will be frequently used in this lesson and subsequent lessons while characterizing different types of rectifiers. Such commonly used terms are defined in this section.

##### 2.1- Mean value :

$$\langle V(t) \rangle = \overline{V(t)} = \frac{1}{T} \int_0^T v(t) dt$$

##### 2.2-Root mean square value (RMS):

$$V_{eff}^2 = \frac{1}{T} \int_0^T v(t)^2 dt$$

**2.3-Form factor:**

The form factor in electrical engineering refers to a dimensionless ratio that characterizes the shape or quality of a waveform, often used in the context of alternating current (AC) voltage or current. It's a measure of how closely the waveform resembles a pure sinusoidal waveform. The closer the form factor is to 1, the closer the waveform resembles a pure sinusoidal waveform. A form factor close to 1 indicates a smoother, less distorted waveform, which is desirable for many electrical applications. This coefficient is used for comparing different rectifier configurations.

The formula for calculating the form factor is typically as follows:

$$F = \frac{V_{eff}}{\bar{V}}$$

$V_{eff}$ : RMS value of the considered voltage;

$\bar{V}$  : Average value of the considered voltage.

**F=1, the closer the obtained voltage is to a continuous quantity.**

**2.4- Ripple Factor:**

The ripple factor is a measure of the amount of alternating current (AC) component or voltage ripple present in a direct current (DC) output. It is typically expressed as a ratio or percentage and is used to evaluate the quality of the DC output from a rectifier or power supply. A lower ripple factor indicates a smoother, more stable DC output, while a higher ripple factor suggests a less stable and noisier output. The ripple factor is an important parameter in power electronics and electrical engineering. By definition, the ripple factor is defined as:

$$k = \frac{V_{max} - V_{min}}{2\bar{V}}$$

$V_{max}$ : Maximum value of the rectified voltage.

$V_{min}$ : Minimum value of the rectified voltage.

**k=0, the closer the rectified voltage is to a continuous quantity.**

**2.5- Distortion factor of a rectifier (DF):**

The ratio of the rms value of the fundamental frequency to the total rms value is the distortion factor:

$$DF = \frac{I_{1rms}}{I_{rms}}$$

$I_1$ : is the fundamental component of current I.

$I_{rms}$ : is the root mean square (RMS) of current I.

The distortion factor represents the reduction in power factor due to the non-sinusoidal property of the current.

### 2.6- Displacement factor of a rectifier (DPF):

If  $V$  and  $I$  are the per phase input voltage and input current of a rectifier respectively, then the displacement factor of a rectifier is defined as:

$$DPF = \cos \varphi$$

Where  $\varphi$  is the phase angle between the fundamental components of  $V$  and  $I$ .

### 2.7- Power factor of rectifier (PF):

As for any other equipment, the definition of the power factor of a rectifier is:

$$PF = \frac{\text{Actual power input to the rectifier}}{\text{Apparent power input to the rectifier}}$$

If the per phase input voltage and current of a rectifier are  $V$  and  $I$  respectively then

$$PF = \frac{V_1 I_1 \cos \varphi}{V_{rms} I_{rms}}$$

If the rectifier is supplied from an ideal sinusoidal voltage source then  $V_1 = V_{rms}$

$$\text{So, } PF = \frac{I_1}{I_{rms}} \cos \varphi = DF \cdot DPF$$

## 3. Uncontrolled rectifiers (Using diodes)

### 3.1 Single-phase half-wave rectifier:

The half-wave rectifier is a simplest electronic circuit that converts alternating current (AC) into pulsating direct current (DC) using a single diode. It's one of the simplest rectification circuits and is typically used when a relatively low Dc output voltage is required. The output voltage and current of this rectifier are strongly influenced by the type of the load. In this section, operation of this rectifier with resistive and inductive loads will be discussed. A thorough understanding of the half-wave rectifier circuit will enable the student to advance to the analysis of more complicated circuits with a minimum of effort.

#### Resistive load (R) :

A basic half-wave rectifier with a resistive load is shown in Fig.2.2a. The source is AC, and the objective is to create a load voltage that has a nonzero DC component. The diode is a basic electronic switch that allows current in one direction only. For the positive half-cycle of the source in this circuit, the diode is on forward biased.

Considering the diode to be ideal, the voltage across a forward-biased diode is zero and the current is positive. For the negative half-cycle of the source, the diode is reverse-biased, making the current zero. The voltage across the reverse-biased diode is the source voltage, which has a negative value. Therefore, the voltage across the resistive load is:

For  $0 \leq \omega t \leq \pi$  :

$$V_c = V_s = v_m \sin(\omega t), \quad V_D = 0, \quad i_c = \frac{V_c}{R}$$

For  $\pi \leq \omega t \leq 2\pi$  :

$$V_c = 0, \quad V_D = V_s = v_m \sin(\omega t), \quad i_c = 0$$

The voltage waveforms across the source, load, and diode are shown in Fig.2.2b.

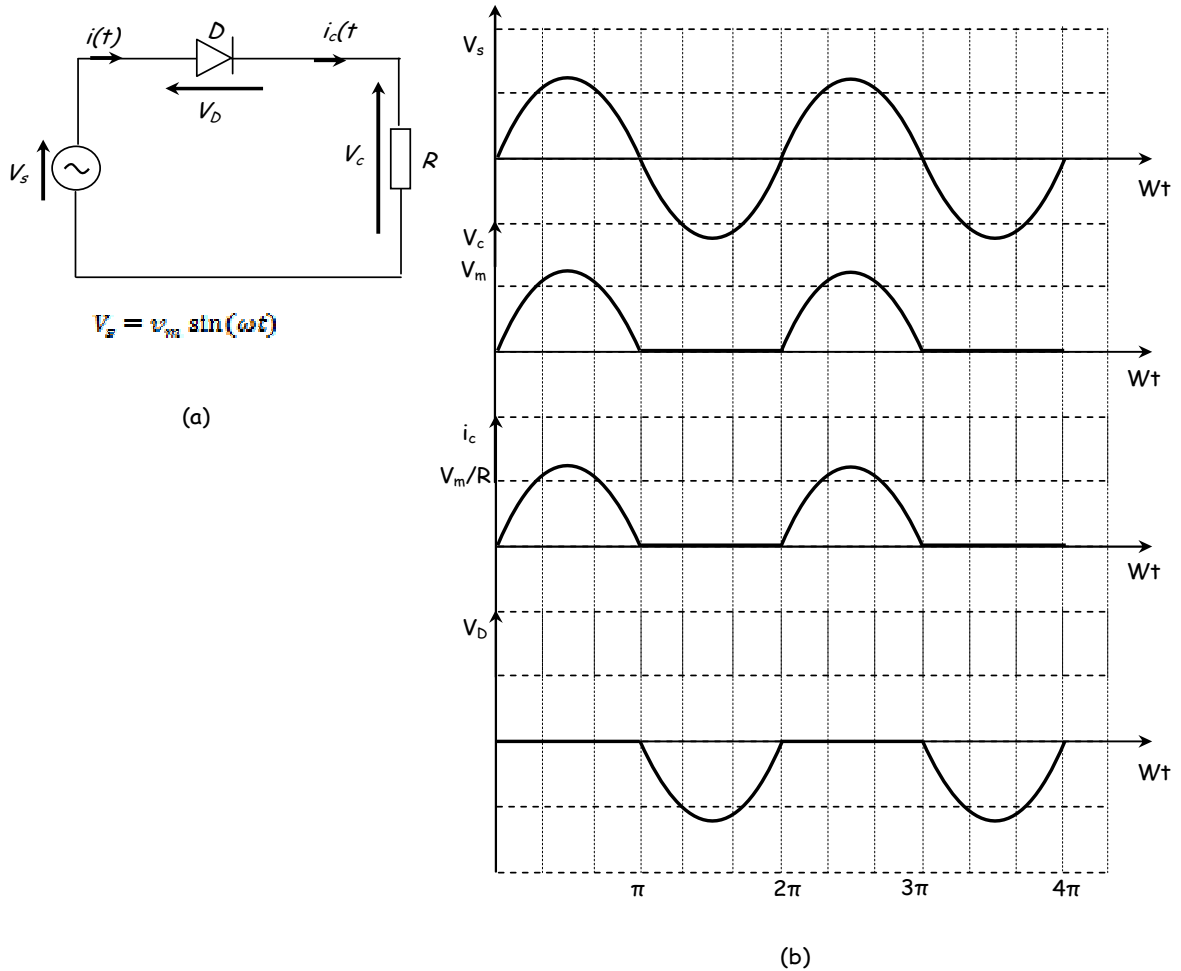

**Fig.2.2** (a) Half-wave rectifier with resistive load; b) Waveforms

The average value of the rectified voltage:

$$\langle V_c \rangle = \frac{1}{T} \int_0^T V_c(t) dt = \frac{1}{T} \int_0^{T/2} V_m \sin(\omega t) dt = \frac{V_m}{\pi} = 0.318V_m$$

The root mean square (RMS) value of the rectified voltage:

$$V_{ceff} = \sqrt{\frac{1}{T} \int_0^T V_c(t)^2 dt} = \sqrt{\frac{1}{T} \int_0^{T/2} (V_m \sin(\omega t))^2 dt} = \sqrt{\frac{V_m^2}{T} \int_0^{T/2} (1 - \cos(2\omega t)) dt} = \frac{V_m}{2} = 0.5V_m$$

The form factor:

$$F = \frac{V_{ceff}}{\langle V_c \rangle} = \frac{\frac{V_m}{2}}{\frac{V_m}{\pi}} = \frac{\pi}{2} = 1.57$$

**Inductive load (RL):**

Industrial loads typically contain inductance as well as resistance. As the source voltage goes through zero, becoming positive in the circuit of Fig.2.3a, the diode becomes forward-biased. For an inductive load, the diode remains conductive as long as the voltage  $V_s$  is positive and the current  $i_c(t)$  is not zero. Therefore, the diode is in forced conduction until the current  $i_c(t)$  becomes zero at the instant  $\beta_0$ . The voltage waveforms across the source, load, and diode are shown in Fig.2.3b.

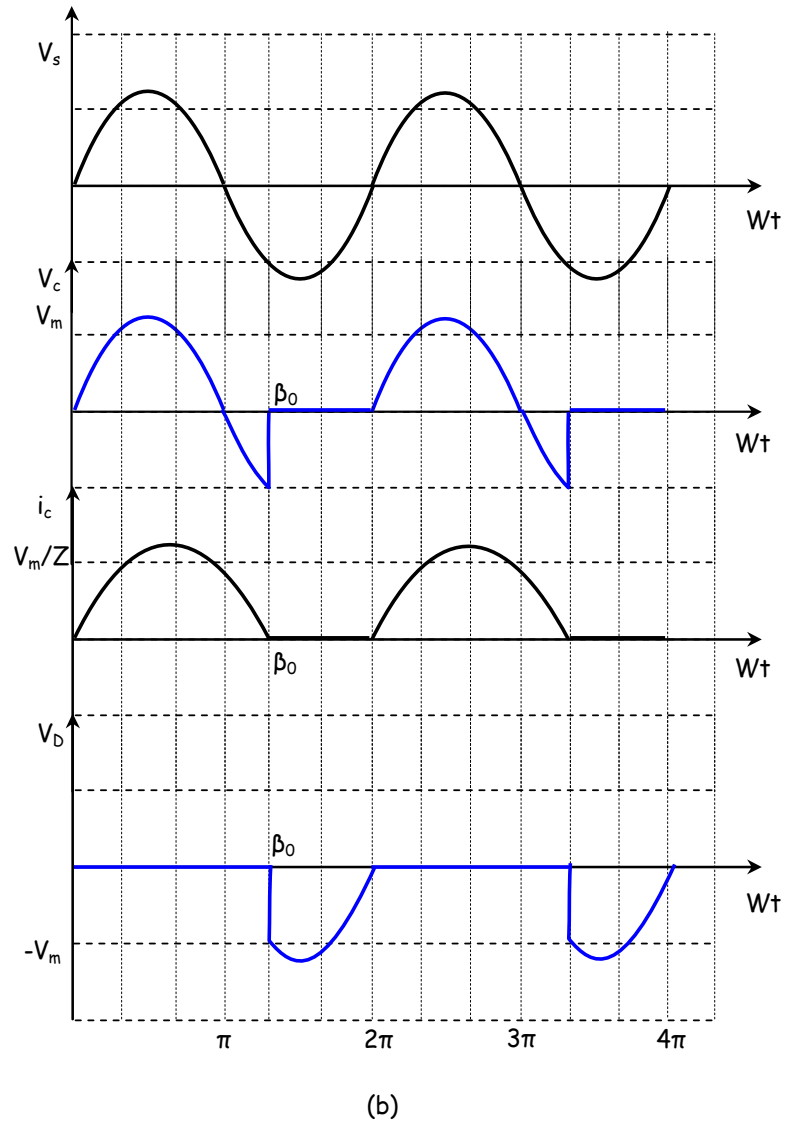
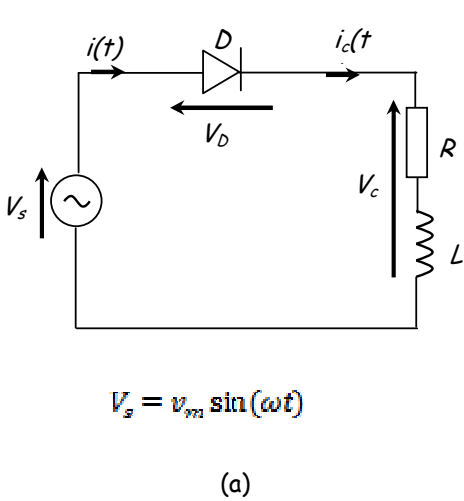

**Fig.2.3** (a) Half-wave rectifier with inductive load; b) Waveforms

For  $0 \leq \omega t \leq \beta_0$  :

$$V_c = V_s = v_m \sin(\omega t), \quad V_D = 0, \quad i_c = \frac{V_c}{Z}$$

For  $\beta_0 \leq \omega t \leq 2\pi$  :

$$V_c = 0, \quad V_D = V_s = v_m \sin(\omega t), \quad i_c = 0$$

The Kirchhoff voltage law equation that describes the current in the circuit for the forward-biased ideal diode is:

$$V_m \sin(\omega t) = Ri(t) + L \frac{di(t)}{dt}$$

The solution can be obtained by expressing the current as the sum of the forced response and the natural response:

$$i(t) = i_f(t) + i_n(t)$$

The forced response for this circuit is the current that exists after the natural response has decayed to zero. In this case, the forced response is the steady-state sinusoidal current that would exist in the circuit if the diode were not present. This steady-state current can be found from phasor analysis, resulting in:

$$i_f(t) = \frac{V_m}{Z} \sin(\omega t - \theta)$$

$$\text{Where } Z = \sqrt{R^2 + (\omega L)^2} \text{ and } \theta = \tan^{-1} \left( \frac{\omega L}{R} \right)$$

The natural response is the transient that occurs when the load is energized. It is the solution to the homogeneous differential equation for the circuit without the source or diode:

$$Ri(t) + L \frac{di(t)}{dt} = 0$$

For this first-order circuit, the natural response is:

$$i_n(t) = Ae^{-\frac{R}{L}t}$$

Adding the forced and natural responses gets the complete solution:

$$i(t) = i_f(t) + i_n(t) = \frac{V_m}{Z} \sin(\omega t - \theta) + Ae^{-\frac{R}{L}t}$$

The constant  $A$  is evaluated by using the initial condition for current. The initial condition of current in the inductor is zero because it was zero before the diode started conducting and it cannot change instantaneously.

The final result is:

$$i(t) = \frac{V_m}{Z} \left[ \sin(\omega t - \theta) + \sin(\theta) e^{-\frac{R}{L}t} \right]$$

### 3.2 Single-phase full-wave rectifier:

The primary goal of a full-wave rectifier (Bridge rectifier) is to generate a voltage or current that is purely direct current (DC) or contains a specified DC component. Although the fundamental purpose of the full-wave rectifier aligns with that of the half-wave rectifier, full-wave rectifiers offer notable advantages. In the full-wave rectifier, the average current from the alternating current (AC) source is reduced to zero, thus mitigating issues related to non-zero average source currents, particularly in transformers. Furthermore, the output of the full-wave rectifier exhibits inherently lower ripple compared to that of the half-wave rectifier.

The single-phase full-wave rectifier circuit (Bridge rectifier), employing diodes, comprises four diodes interconnected in pairs in reverse, as depicted in Figure 2.4a.

#### Resistive load :

For  $0 \leq \omega t \leq \pi$ : The voltage is positive, with diodes  $D_1$  and  $D_4$  conducting, while  $D_2$  and  $D_3$  are blocked.

$$V_c = V_s = v_m \sin(\omega t)$$

$$V_{D1} = 0, V_{D4} = 0$$

$$i_c = \frac{V_c}{R}$$

For  $\pi \leq \omega t \leq 2\pi$ : The voltage is negative, with diodes  $D_2$  and  $D_3$  conducting, while  $D_1$  and  $D_4$  are blocked.

$$V_c = -V_s = -v_m \sin(\omega t)$$

$$V_{D2} = 0, V_{D3} = 0$$

$$V_{D1} = V_s, V_{D4} = V_s$$

$$i_c = \frac{V_c}{R}$$

The voltage waveforms across the source, load, and diode are shown in Fig.2.4b.

-The DC component of the output voltage is the average value of the rectified voltage:

$$\langle V_c \rangle = \frac{2}{T} \int_0^{T/2} V_c(t) dt = \frac{2}{T} \int_0^{T/2} V_m \sin(\omega t) dt = \frac{2V_m}{\pi} = 0.636V_m$$

-The root mean square (RMS) value of the rectified voltage:

$$V_{ceff} = \sqrt{\frac{1}{T} \int_0^T V_c(t)^2 dt} = \sqrt{\frac{2}{T} \int_0^{T/2} (V_m \sin(\omega t))^2 dt} = \sqrt{\frac{2V_m^2}{T} \int_0^{T/2} (1 - \cos(2\omega t)) dt} = \frac{V_m}{\sqrt{2}} = 0.707V_m$$

-The form factor :

$$F = \frac{V_{ceff}}{\langle V_c \rangle} = \frac{\frac{V_m}{\sqrt{2}}}{\frac{2V_m}{\pi}} = \frac{\pi}{2\sqrt{2}} = 1.11$$

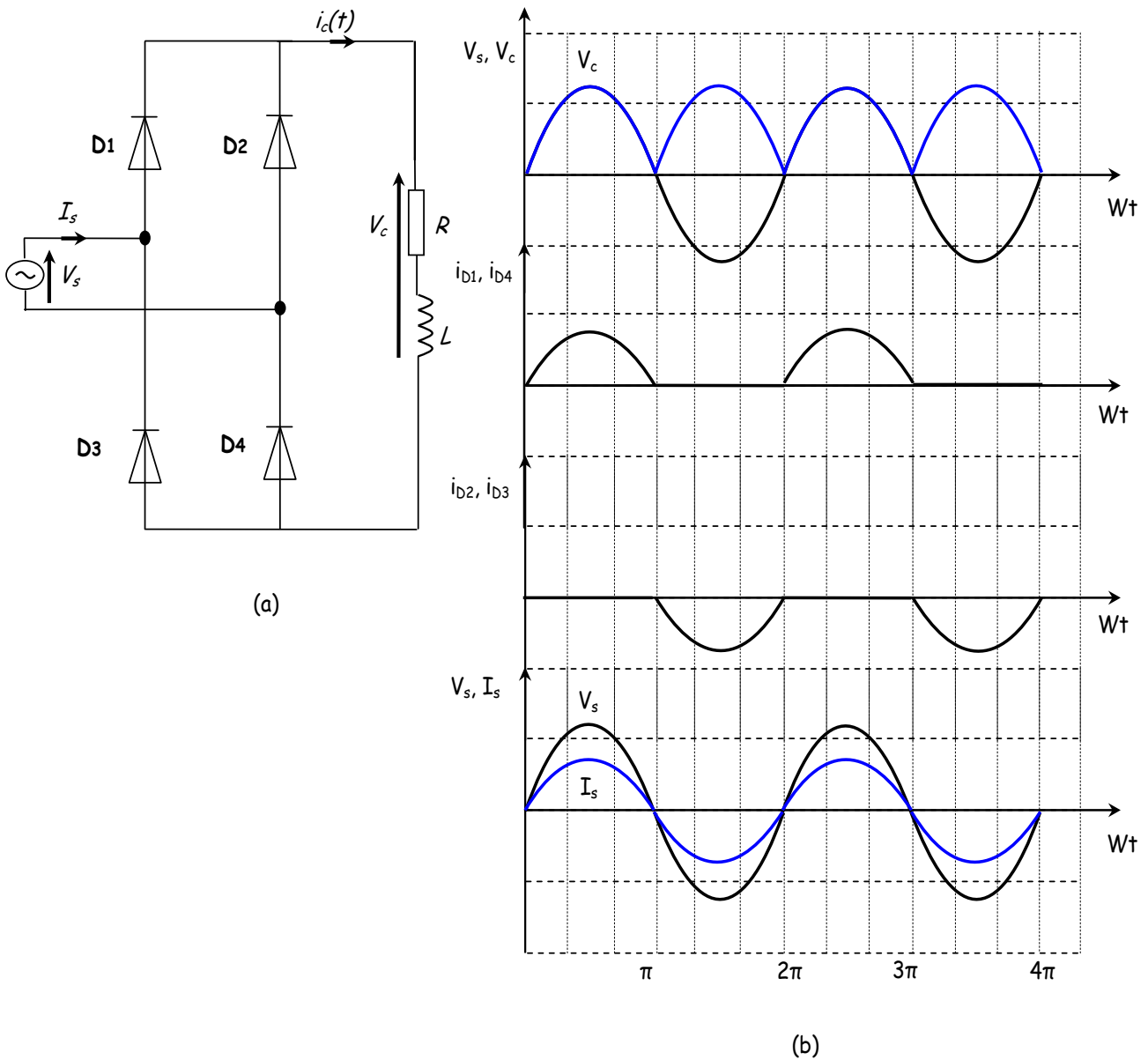

**Fig.2.4** (a) Full-wave rectifier with resistive load; b) Waveforms



**Inductive load :**

The load now consists of a pure inductance  $L$  in series with a resistance  $R$ . The inductance  $L$  opposes variations in the current  $i_c(t)$  and smoothes it out. If a sufficient value is provided, the current in the load becomes continuous (the current does not pass through zero), and this is known as continuous conduction mode.

If  $L$  is significant enough ( $L \gg$ ), the current  $i_c(t)$  can be considered constant and equal to  $I_c$ .

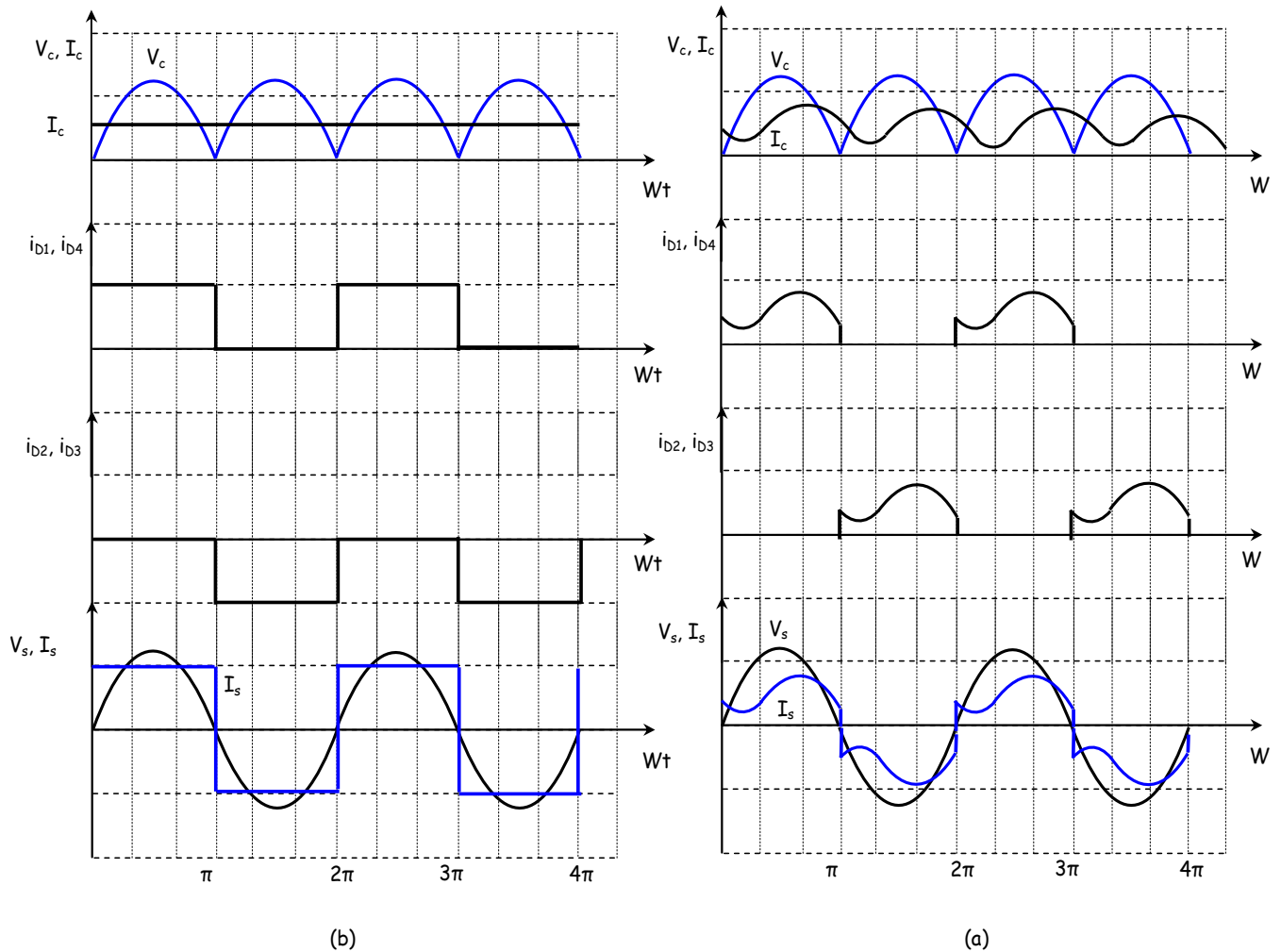
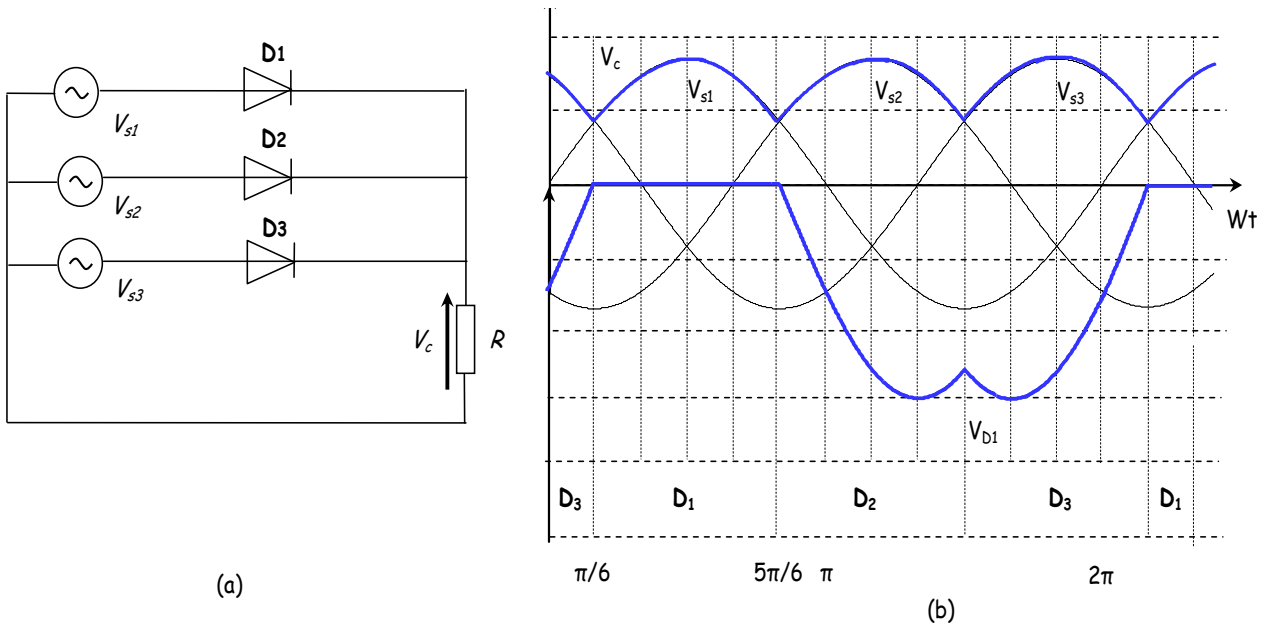

**Fig.2.5** Waveforms: (a) inductive load; (b) Highly inductive load

**3.3 Three-phase half-wave rectifier:**

As shown in Figure 2.6a, one diode is conducting at any given moment. It is the diode connected to the phase with the highest instantaneous voltage. The output voltage varies from  $V_m/2$  to  $V_m$  three times during each input cycle.

The voltage waveforms across the load and diode  $D_1$  are shown in Fig.2.6b.



**Fig.2.6** (a) Three-phase half-wave rectifier with resistive load; b) Waveforms

-The average or DC value of the output voltage is:

$$\langle V_c \rangle = \frac{3}{T} \int_{T/12}^{5T/12} V_c(t) dt = \frac{3}{2\pi} \int_{\pi/6}^{5\pi/6} V_m \sin(\omega t) d\omega t = \frac{3\sqrt{3}V_m}{2\pi} = 0.827V_m$$

-The root mean square (RMS) value of the rectified voltage:

$$V_{ceff} = \sqrt{\frac{3}{2\pi} \int_{\pi/6}^{5\pi/6} (V_m \sin(\omega t))^2 d\omega t} = \sqrt{\frac{3V_m^2}{4\pi} \int_{\pi/6}^{5\pi/6} (1 - \cos(2\omega t)) d\omega t} = 0.8407V_m$$

-The form factor :

$$F = \frac{V_{ceff}}{\langle V_c \rangle} = \frac{0.8407V_m}{0.827V_m} = 1.016$$

**3.4 Three-phase full-wave rectifier:**

The three-phase full-bridge rectifier is shown in Fig 2.7a. Kirchoff’s voltage la around any path shows that:

1-only one diode in the top half of the bridge may conduct at one time (D1, D3, or D5). The diode that is conducting will have its anode connected to the phase voltage that is highest at that instant.

2-only one diode in the bottom half of the bridge may conduct at one time (D2, D4, or D6). The diode that is conducting will have its cathode connected to the phase voltage that is lowest at that instant.

3-as a consequence of items 1 and 2, diodes on the same leg (D1 and D4, D3 and D6, D2 and D5) cannot conduct at the same time.

4-The output voltage across the load is one of the line-to-line voltages of the source. For example, when D1 and D2 are on, the output voltage is  $V_{ac}$ . Furthermore, the diodes that are on are determined by which line-to-line voltage is the highest at that instant. For example, when  $V_{ac}$  is the highest line-to-line voltage, the output is  $V_{ac}$ .

5-The fundamental frequency of the output voltage is  $6\omega$ , where  $\omega$  is the frequency of the three-phase source.

The voltage waveforms across the load and diode  $D_1$  are shown in Fig.2.7b.

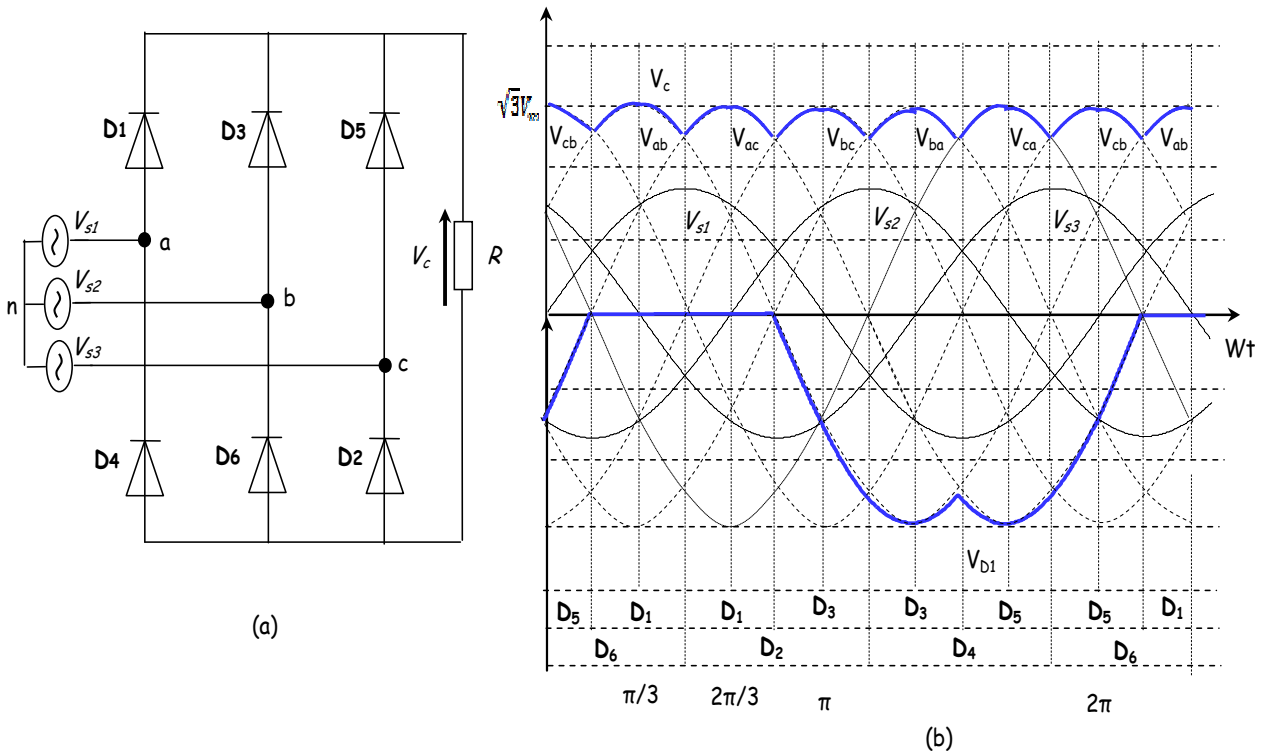

**Fig.2.7** (a) Three-phase full-wave rectifier with resistive load; b) Waveforms

If we define the three line-neutral voltages as follows:

$$\begin{cases} v_{s1} = V_m \sin \omega t \\ v_{s2} = V_m \sin \left( \omega t - \frac{2\pi}{3} \right) \\ v_{s3} = V_m \sin \left( \omega t + \frac{2\pi}{3} \right) \end{cases}$$

The corresponding line-to-line voltages are:

$$\begin{cases} v_{ab} = v_{an} - v_{bn} = \sqrt{3}V_m \sin\left(\omega t + \frac{\pi}{6}\right) \\ v_{bc} = v_{bn} - v_{cn} = \sqrt{3}V_m \sin\left(\omega t - \frac{\pi}{2}\right) \\ v_{ca} = v_{cn} - v_{an} = \sqrt{3}V_m \sin\left(\omega t + \frac{5\pi}{6}\right) \end{cases}$$

Where  $V_m$  is the peak phase voltage of a wye-connected source.

-The average or DC value of the output voltage is:

$$\langle V_c \rangle = \frac{6}{T} \int_{T/12}^{3T/12} V_c(t) dt = \frac{3}{\pi} \int_{\pi/6}^{\pi/2} V_{ab}(t) d\omega t = \frac{3}{\pi} \int_{\pi/6}^{\pi/2} \left( V_m \sin(\omega t) - V_m \sin\left(\omega t - \frac{2\pi}{3}\right) \right) d\omega t = 1.654V_m$$

-The root mean square (RMS) value of the rectified voltage:

$$V_{ceff} = \sqrt{\frac{3}{\pi} \int_{\pi/6}^{\pi/2} \left( V_m \sin(\omega t) - V_m \sin\left(\omega t - \frac{2\pi}{3}\right) \right)^2 d\omega t} = 1.6554V_m$$

-The form factor :

$$F = \frac{V_{ceff}}{\langle V_c \rangle} = \frac{1.6554V_m}{1.654V_m} = 1.0008$$

## 4. Controlled rectifiers (Using Thyristors)

### 4.1 Single-phase half-wave rectifier

In this chapter, we've examined uncontrolled rectifiers, specifically half-wave rectifiers. Once the source and load parameters are determined, the resulting DC output level and the power delivered to the load are constant values. By using thyristor instead of a diode, we can control over the half-wave rectifier's output. Fig 2.8a shows the circuit diagram of a single phase half-wave rectifier with resistive load. Two conditions must be met before the thyristor can conduct:

1. The thyristor must be forward-biased ( $V_{th} > 0$ ).
2. A current must be applied to the gate of the thyristor.

Unlike the diode, the thyristor will not begin to conduct as soon as the source becomes positive. Conduction is delayed until a gate current is applied, which is the basis for using the thyristor as a means of control. Once the thyristor is conducting, the gate current can be removed and the thyristor remains on until the current goes to zero.

**Resistive load:**

The voltage waveforms across the source, load, and diode are shown in Fig.2.8b. A gate signal is applied to the thyristor at  $\omega t = \alpha$ , where  $\alpha$  is the delay angle.

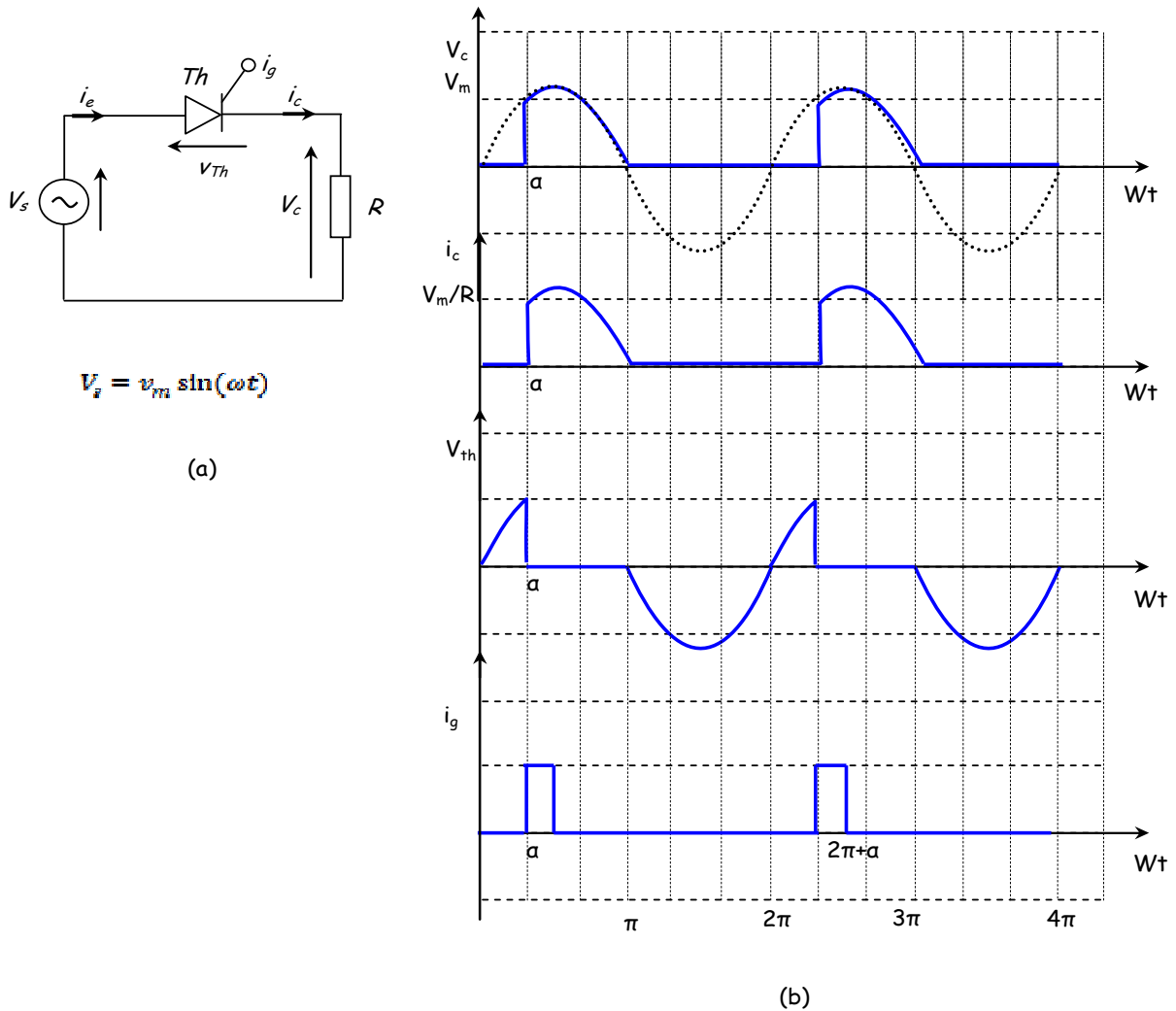

**Fig.2.8** (a) Half-wave rectifier with resistive load; b) Waveforms

For  $0 \leq \omega t \leq \alpha$  : The voltage  $V_s$  is positive, and  $i_g=0$ , the thyristor is blocked.

$$i_c = 0, V_c = 0, V_{th} = V_s$$

For  $\alpha \leq \omega t \leq \pi$  : The voltage  $V_s$  is positive, and  $i_g>0$ , the thyristor is conducting.

$$V_{th} = 0, \quad V_c = V_s = v_m \sin(\omega t), \quad i_c = \frac{V_c}{R}$$

For  $\pi \leq \omega t \leq 2\pi$  : The voltage  $V_s$  is negative, the thyristor is blocked.

$$i_c = 0, \quad V_c = 0, \quad V_{th} = V_s$$

-The average value of the rectified voltage:

$$\langle V_c \rangle = \frac{1}{T} \int_0^T V_c(t) dt = \frac{1}{2\pi} \int_{\alpha}^{2\pi} V_m \sin(\omega t) d\omega t = \frac{V_m}{2\pi} (1 + \cos \alpha)$$

The average value of the rectified voltage varies depending on  $\alpha$ , the timing of the trigger pulse application.

**Inductive load :**

For an inductive load, the thyristor remains conducting for a negative voltage until the current  $i_c(t)$  cancels out at the angle ( $\beta$ ). The voltage waveforms across the source, load, and diode are shown in Fig.2.9b.

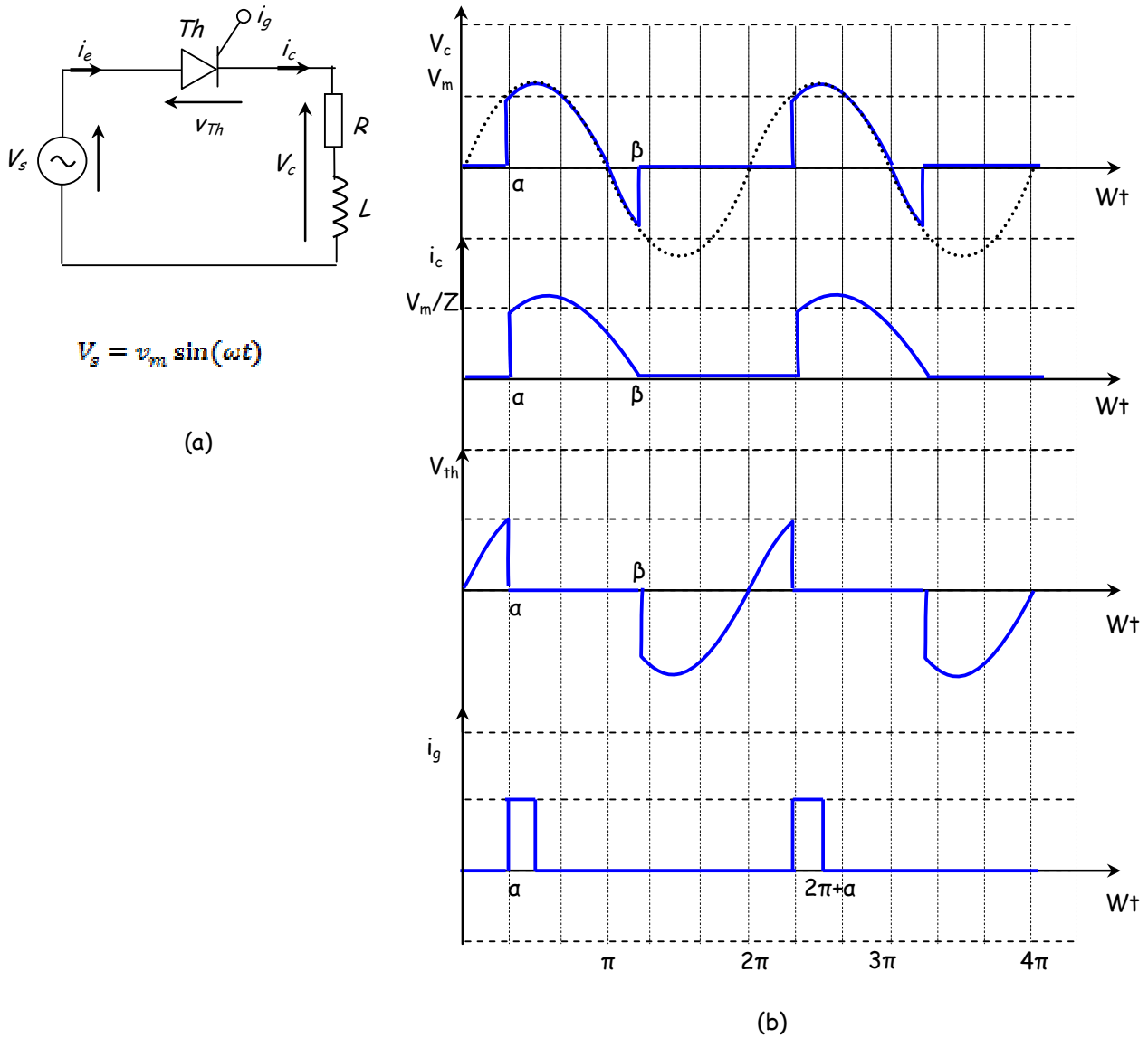

**Fig.2.9** (a) Half-wave rectifier with inductive load; b) Waveforms

-The average value of the rectified voltage:

$$\langle V_c \rangle = \frac{1}{T} \int_0^T V_c(t) dt = \frac{1}{2\pi} \int_{\alpha}^{\beta} V_m \sin(\omega t) d\omega t = \frac{V_m}{2\pi} (\cos \alpha - \cos \beta)$$

### 4.2 Single-phase full-wave rectifier

The controlled full-wave rectifier circuit is made up of four thyristors connected in pairs in reverse as shown in Fig.2.10a. For the bridge rectifier, thyristors Th1 and Th4 will become forward-biased when the source becomes positive but will not conduct until gate signals are applied. Similarly, Th2 and Th3 will become forward-biased when the source becomes negative but will not conduct until they receive gate signals.

The delay angle  $\alpha$  is the angle interval between the forward biasing of the thyristor and the gate signal application. If the delay angle is zero, the rectifier behaves exactly as uncontrolled rectifier with diodes.

#### Resistive Load:

The voltage waveforms across the source, load, and diode are shown in Fig.2.10b.

The gate signals are sent to the gate terminals of the thyristors at the following angles:

For th<sub>1</sub> and th<sub>4</sub> :  $\omega t = \alpha$ , For th<sub>2</sub> and th<sub>3</sub> :  $\omega t = \alpha + \pi$

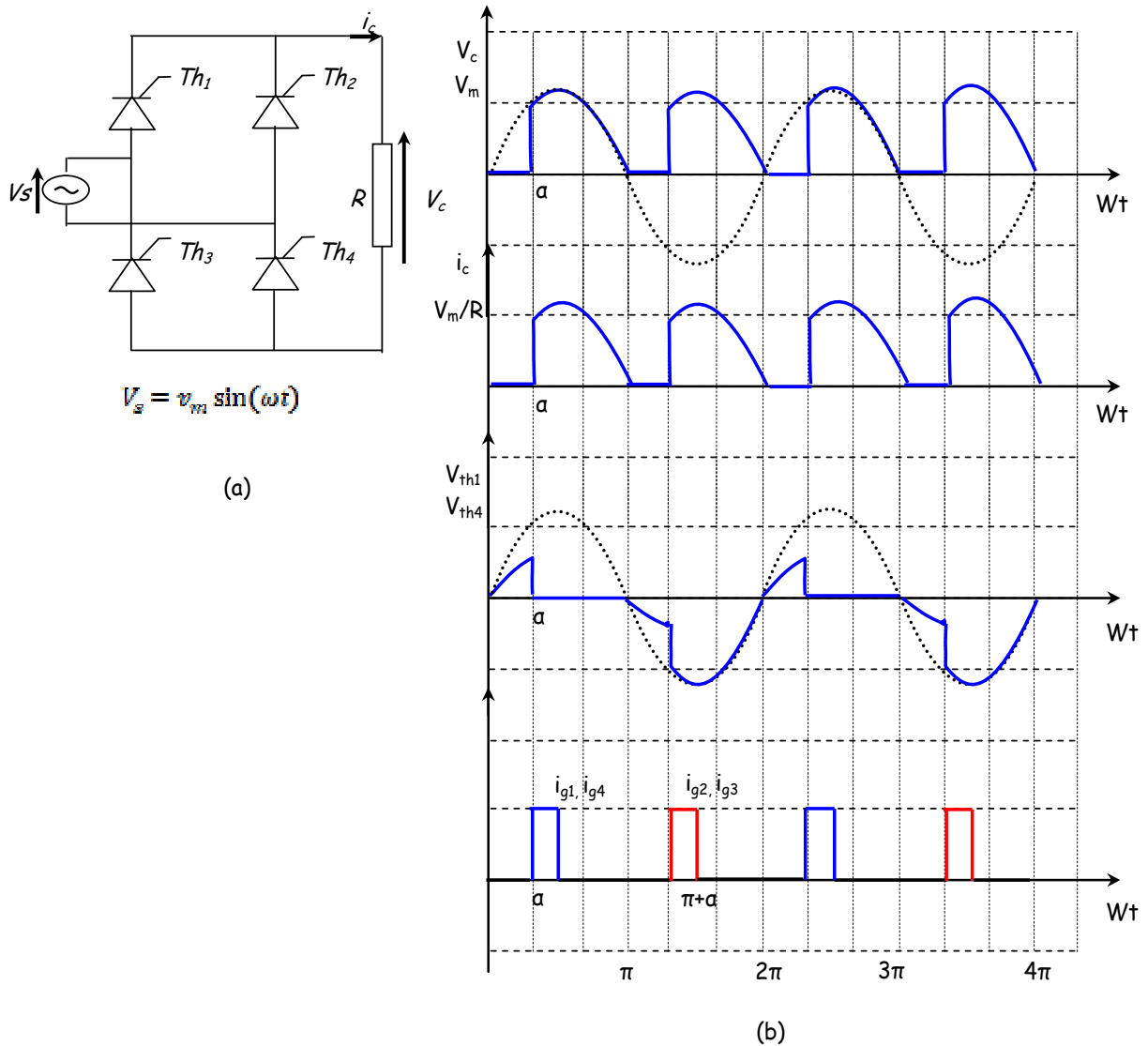

**Fig.2.10** (a) Full-wave rectifier with resistive load; b) Waveforms

For  $0 \leq \omega t \leq \alpha$  and  $\pi \leq \omega t \leq \pi + \alpha$

( $i_{g1}=0, i_{g2}=0, i_{g3}=0, i_{g4}=0$ ): The four thyristors ( $th_1, th_2, th_3, th_4$ ) are blocked.

$$i_c = 0$$

$$V_c = 0$$

$$V_{th1} = V_{th4} = V_s/2$$

For  $\alpha \leq \omega t \leq \pi$  :

The voltage  $V_s$  is positive, and  $i_{g1}>0, i_{g4}>0$ . In this case, the thyristors  $th_1$  and  $th_4$  are conducting, while  $th_2$  and  $th_3$  are blocked.

$$V_{th1} = V_{th4} = 0$$

$$V_c = V_s = v_m \sin(\omega t)$$

$$i_c = \frac{V_c}{R}$$

For  $\pi + \alpha \leq \omega t \leq 2\pi$  :

The voltage is negative, and  $i_{g2}>0, i_{g3}>0$ . In this scenario, the thyristors  $th_2$  and  $th_3$  are conducting, while  $th_1$  and  $th_4$  are blocked.

$$V_{th1} = V_{th4} = v_m \sin(\omega t)$$

$$V_c = -V_s = -v_m \sin(\omega t)$$

$$i_c = \frac{V_c}{R}$$

-The average value of the rectified voltage:

$$\langle V_c \rangle = \frac{1}{T} \int_0^T V_c(t) dt = \frac{1}{\pi} \int_{\alpha}^{\pi} V_m \sin(\omega t) d\omega t = \frac{V_m}{\pi} (1 + \cos \alpha)$$

### **Inductive load :**

For an inductive load, the thyristors  $th_1$  and  $th_4$  remain conducting until the current  $i_c(t)$  becomes zero at the angle  $\beta$  ( $i_c(\beta)=0$ ). For a highly inductive load ( $L \gg \omega L$ ), the thyristors  $th_1$  and  $th_4$  remain conducting until the thyristors  $th_2$  and  $th_3$  are triggered.

The voltage waveforms across the source, load, and diode are shown in Fig.2.11b and Fig.2.11c.



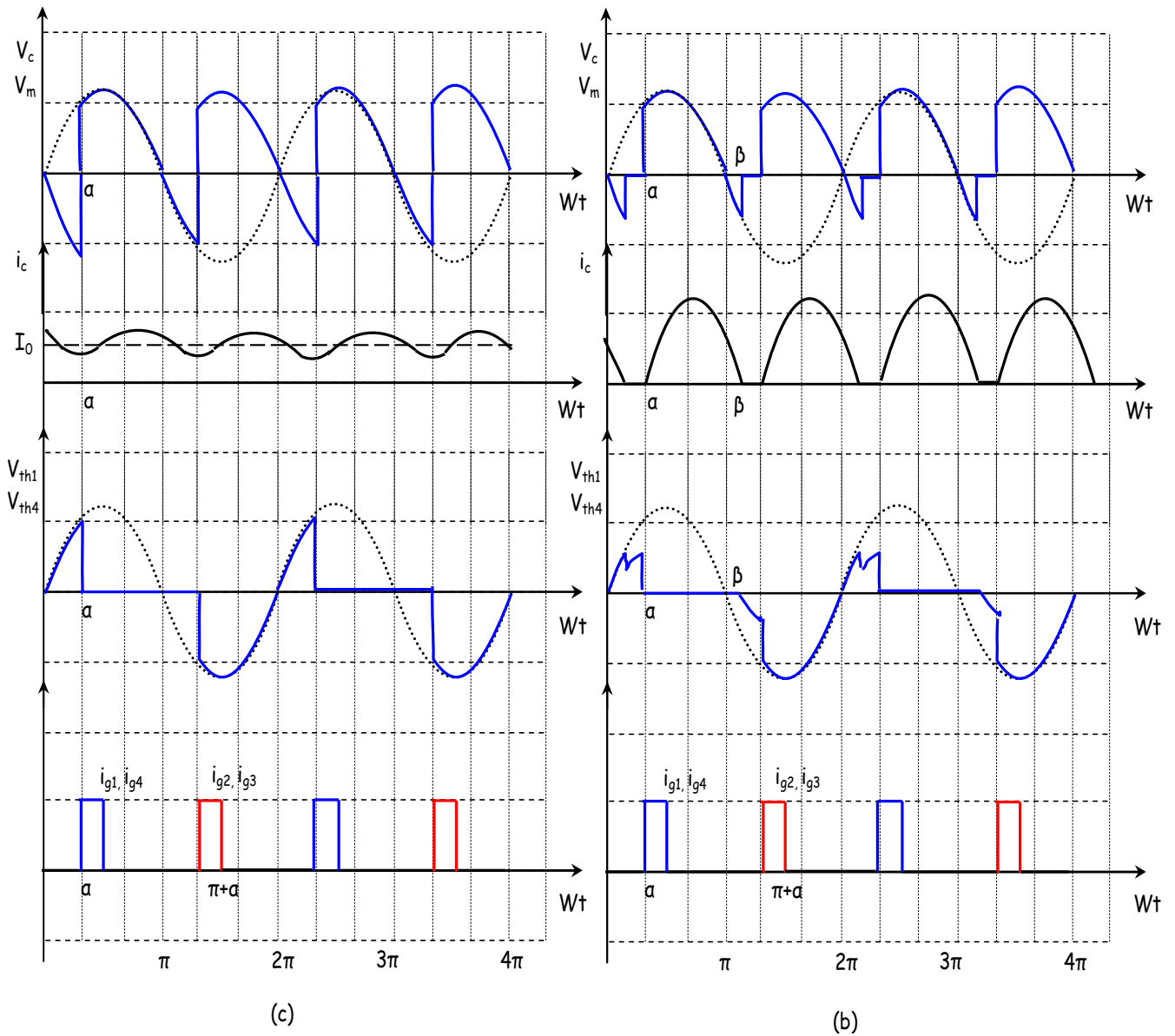

**Fig.2.11 Fig.2.5** Waveforms: (b) inductive load; (c) Highly inductive load

### 4.3 Three-phase half-wave rectifier

The onset of conduction in any phase can be delayed by adjusting the firing angle of the thyristor connected to that phase. To initiate conduction, it is essential for the anode voltage of the thyristor to be positive relative to its cathode. Consequently, thyristor th1, which is linked to phase 1 in Fig 2.12a, cannot be triggered successfully until  $\omega t = \pi/6$ . Prior to this moment, as illustrated in Fig 2.12b, the voltage  $v_{s1}$  is less positive than  $v_{s3}$ , causing thyristor th1 to be in a reverse-biased state. Hence, the crossover point of successive phase voltages (i.e.,  $\omega t = \pi/6$ ) serves as the zero or reference point from which the firing angle is measured.

When thyristor th1 is fired at  $\omega t = \alpha + \pi/6$ , voltage  $v_{s1}$  becomes across the load until zero current is achieved (for a resistive load, Fig 2.12b) or until th2 is triggered at  $\omega t = \alpha + 5\pi/6$  (for an inductive load, Fig 2.13b). Once thyristor th2 is fired, th1 becomes reverse biased because the line-to-line voltage turns

negative, thus th1 is turned off. Subsequently, voltage  $v_{s2}$  becomes across the load until zero current is attained (for a resistive load, Fig 2.12b) or until th3 is triggered at  $\omega t = \alpha + 3\pi/2$  (for an inductive load, Fig 2.13b). When th3 is fired, th2 is turned off, and voltage  $v_{s3}$  appears across the load until zero current is reached (for a resistive load, Fig 2.12b) or until th1 is triggered again at the beginning of the next cycle.

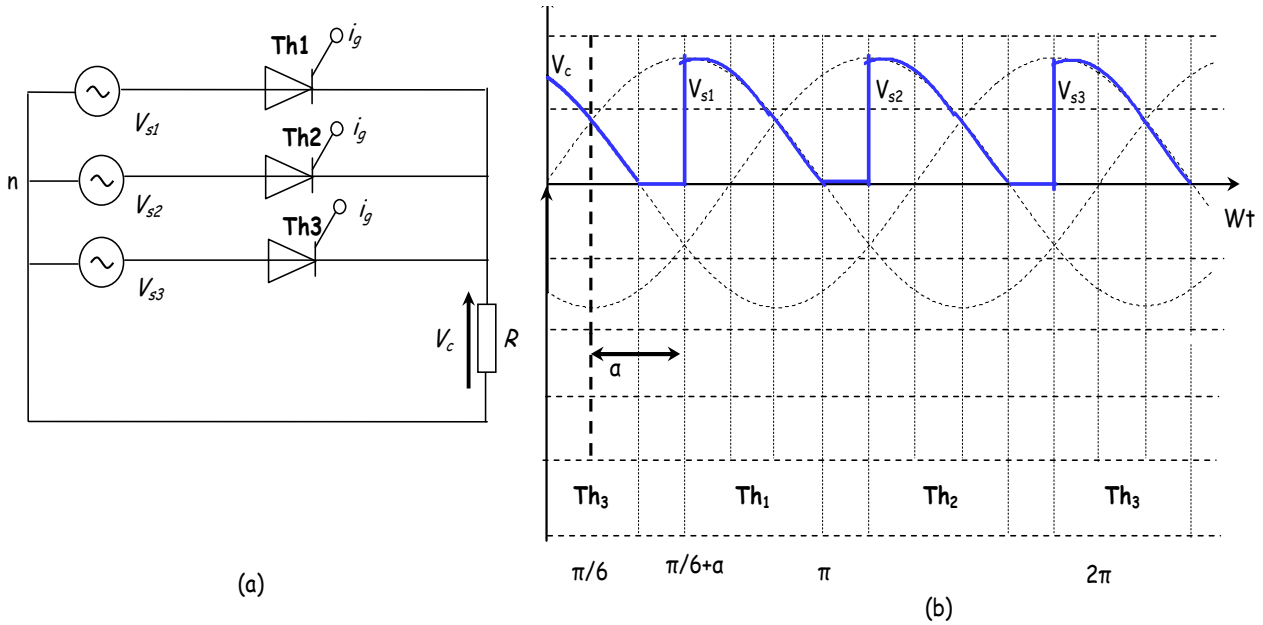

Fig.2.12 (a) Three-phase half-wave rectifier with resistive load; b) Waveforms ( $\alpha=\pi/3$ )

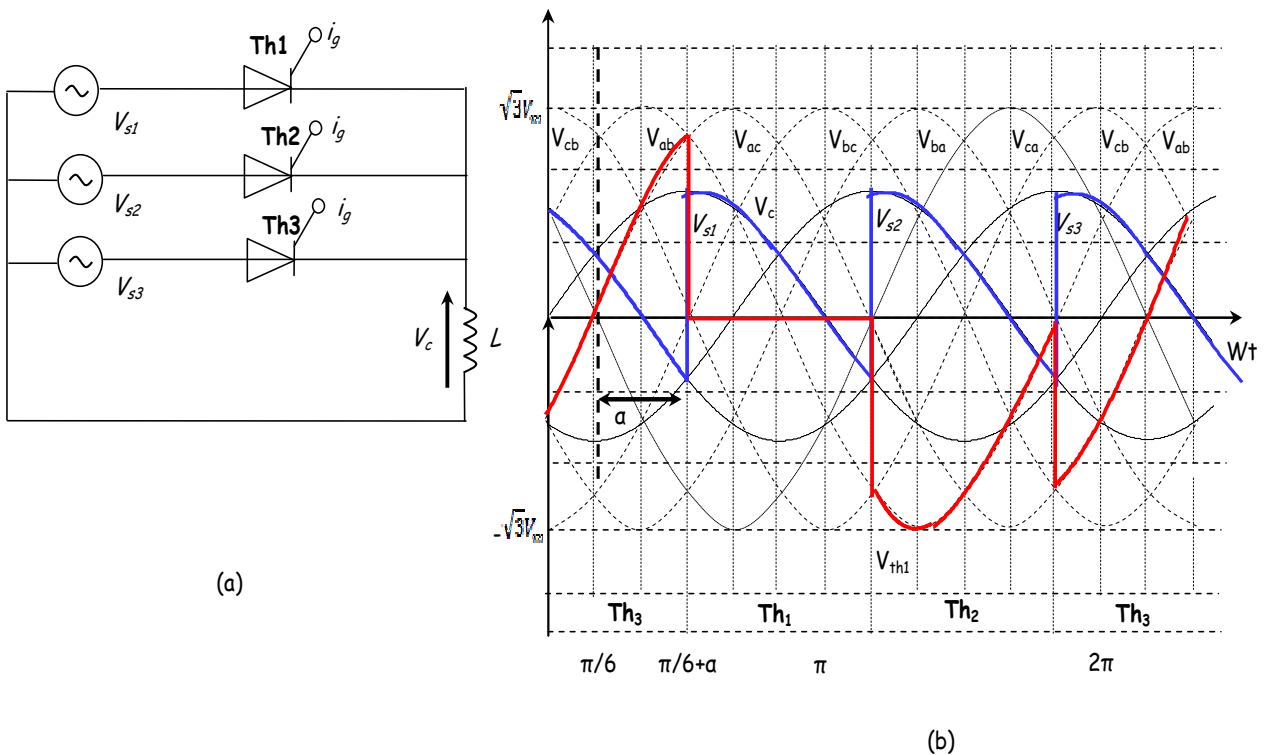

Fig.2.13 (a) Three-phase half-wave rectifier with inductive load; b) Waveforms ( $\alpha=\pi/3$ )

-The voltage across thyristors th1, th2 and th3 is:

$$V_{th1} = V_{s1} - V_c, \quad V_{th2} = V_{s2} - V_c, \quad \text{and} \quad V_{th3} = V_{s3} - V_c$$

Where:  $V_c = \{V_{s1}, V_{s2}, V_{s3}\}$

-The average value of the rectified voltage:

$$\langle V_c \rangle = \frac{3}{2\pi} \int_{\frac{\pi}{6}+\alpha}^{\frac{5\pi}{6}+\alpha} V_m \sin(\omega t) d\omega t = \frac{3\sqrt{3}V_m}{2\pi} \cos \alpha$$

**4.4 Three-phase full-wave rectifier**

Three-phase converters, often referred to as 6-pulse converters, are widely used in industrial applications up to the 120-kilowatt (kW) level. These converters are a type of power electronic device that plays a crucial role in converting alternating current (AC) to direct current (DC) or vice versa in three-phase electrical systems. They are commonly used in various industrial settings for a range of applications, including motor drives, control systems, and power distribution. Figure 2.14a shows a full-converter circuit with a highly inductive load. Its operation is similar to the three-phase full wave rectifier of Fig 2.7b, except that commutation is delayed by  $\alpha$  from when commutation occurs between diodes in Fig 2.7b. The output voltage waveforms are given for firing angle  $\alpha=\pi/6$  in Fig 2.14b.

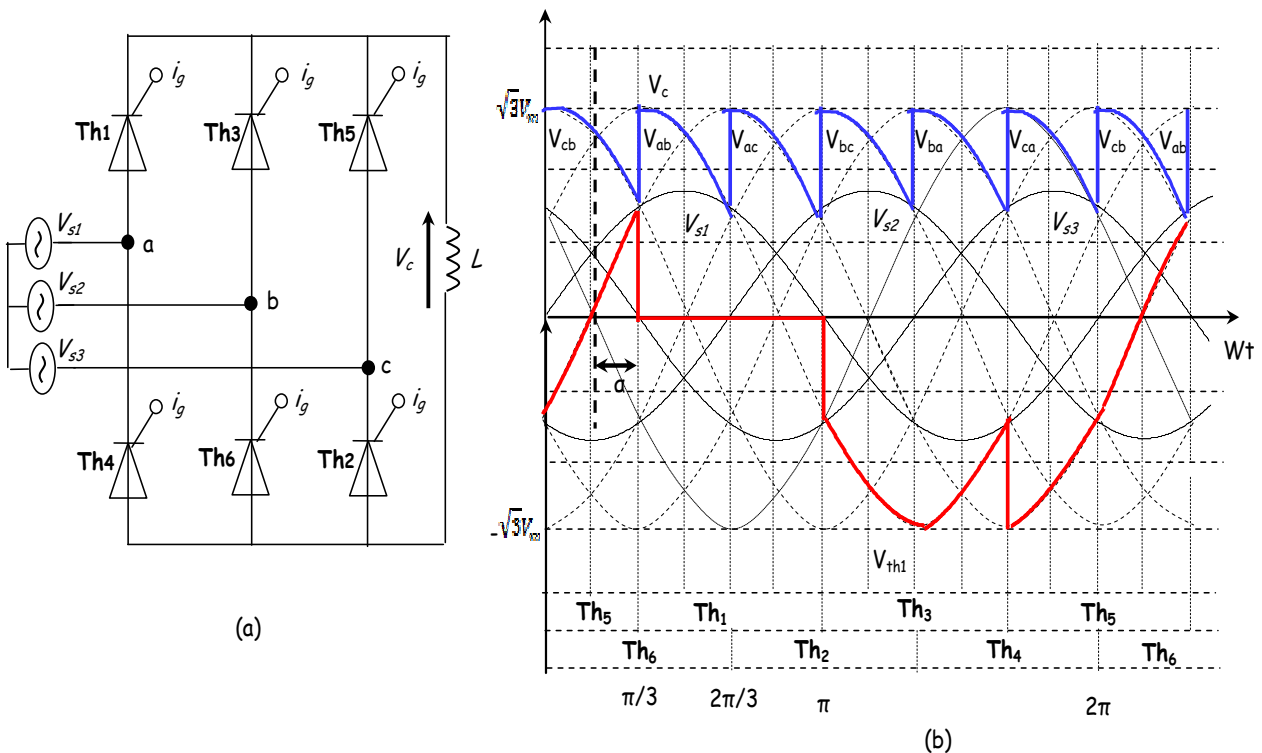

**Fig.2.14** (a) Three-phase full-wave rectifier with inductive load; b) Waveforms ( $\alpha=\pi/6$ )

-The voltage across thyristor th1 is:

$$V_{th1} = V_{s1} - V_{s2} \text{ when th3 is conducting}$$

$$V_{th1} = V_{s1} - V_{s3} \text{ when th5 is conducting}$$

-The average value of the rectified voltage:

$$\langle V_c \rangle = \frac{6}{2\pi} \int_{\frac{\pi}{6}+\alpha}^{\frac{\pi}{2}+\alpha} V_{ab} d\omega t = \frac{3}{\pi} \int_{\frac{\pi}{6}+\alpha}^{\frac{\pi}{2}+\alpha} \sqrt{3}V_m \sin\left(\omega t + \frac{\pi}{6}\right) d\omega t = \frac{3\sqrt{3}V_m}{\pi} \cos \alpha$$

The output voltage waveforms are given for different firing angles ( $\alpha=0, \alpha=\pi/2, \alpha=\pi$ ) in Fig 2.15a, b, c.

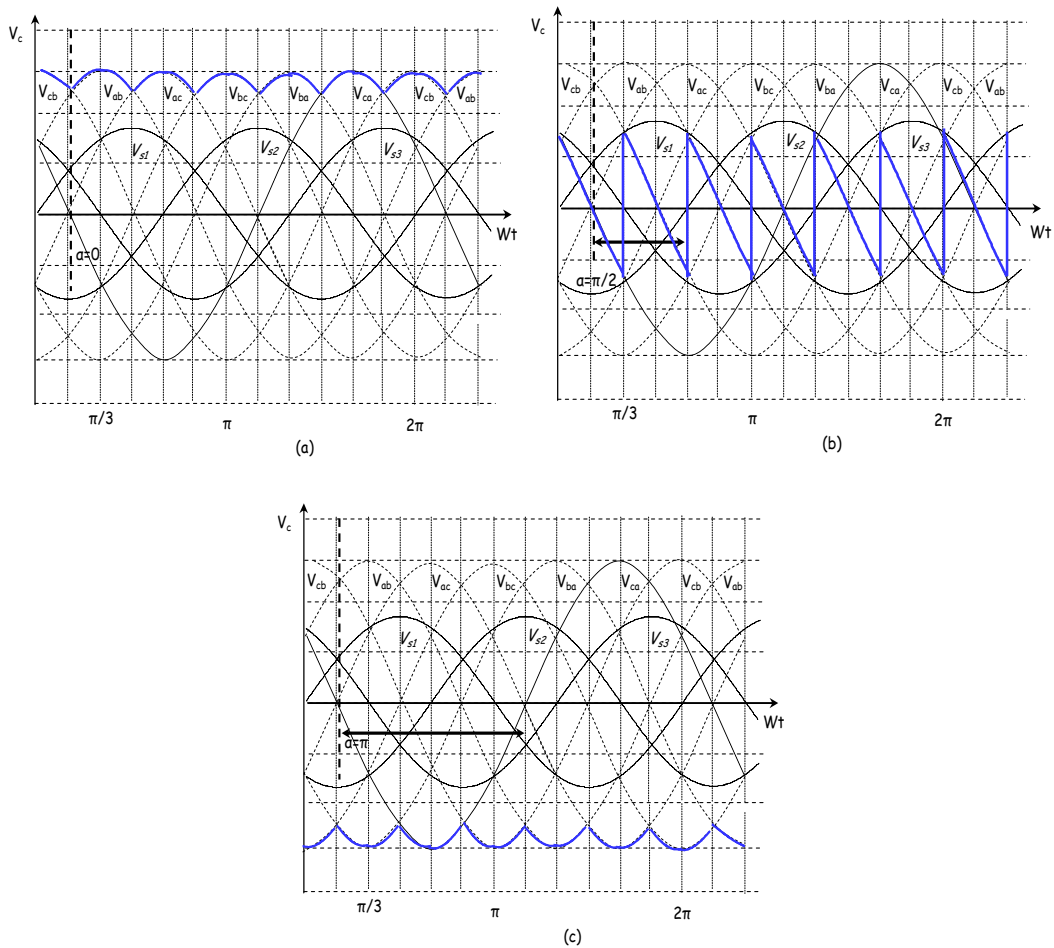

**Fig.2.15** Waveforms : a)  $\alpha=0$ , b)  $\alpha=\pi/2$ , c)  $\alpha=\pi$

**5. Problems:****Problem 2-1:**

Consider the following circuit representing an uncontrolled half-wave rectifier.

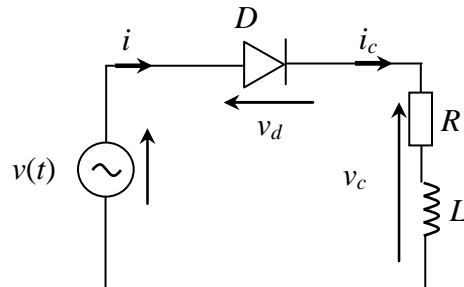

- 1- Determine an expression for the current  $i(t)$  in the circuit.
- 2- Plot the waveform of the current  $i_c(t)$ , the voltage  $V_c$ , and the voltage  $V_d$  over the interval  $[0, 2\pi]$ .
- 3- If a diode is added in parallel with the load ( $R, L$ ), plot the new waveforms of the current  $i_c(t)$ , the voltage  $V_c$ , and the voltage  $V_d$  over the interval  $[0, 2\pi]$ .

**Problem 2-2:**

Consider the following circuit representing an uncontrolled full-wave center-tapped rectifier.

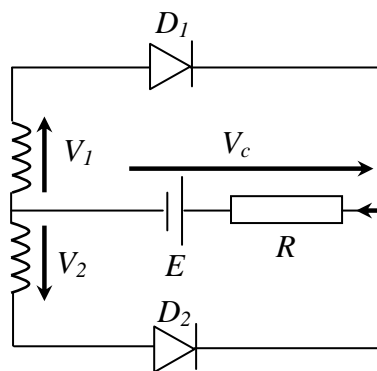

For both cases: (a)  $E=0$  V and  $R=1$   $\Omega$ , (b)  $E=90$  V and  $R=1$   $\Omega$ .

- 1- Plot the waveforms of voltage and current across the load.
- 2- Calculate the power dissipated in the load.

Given that:  $V_1 = 110 \sqrt{2} \sin(314 t)$  and  $V_2 = -V_1$

**Problem 2-3:**

Consider a PD2 rectifier circuit with thyristors, supplied by an ideal sinusoidal source, feeding a resistive load R.

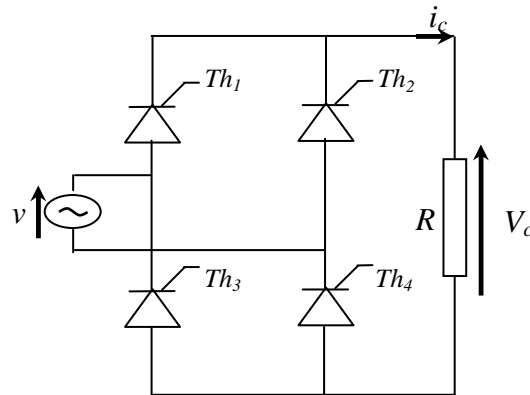

- 1- For a firing angle  $\alpha=45^\circ$ , plot the waveforms of voltage  $V_c$ , current in the load  $i_c$ , and voltage  $V_{Th1}$  for a resistive load (R).
- 2- Calculate the power dissipated in the load.
- 3- Calculate the form factor of the rectified voltage.
- 4- Calculate the power factor at the secondary of the transformer.
- 5- For a firing angle  $\alpha=45^\circ$ , plot the waveforms of voltage  $V_c$ , current in the load  $i_c$ , and voltage  $V_{Th1}$  for a resistive-inductive load (R, L).

Data:  $V_m = 220\sqrt{2}$  V,  $f = 50$  Hz,  $R = 10$  Ohm.

Note: Thyristors are assumed to be ideal.

**Solution 2-1 :****1-The expression of  $i(t)$  ?**

If we assume that D is on:  $v(t) - Ri(t) - V_c(t) = 0$

$$v(t) = Ri(t) + L \frac{di(t)}{dt}$$

The solution to this first-order differential equation is the sum of two solutions:  $i = i_l + i_f$

$$Ri_l(t) + L \frac{di_l(t)}{dt} = 0$$

$$\int \frac{i_l}{i_l} = \frac{-R}{L} \int dt \rightarrow \log(i_l) = \frac{-R}{L}t + c \rightarrow i_l(t) = B \cdot e^{-\frac{R}{L}t}$$

$$i_f = I_m \sin(\omega t - \varphi)$$

$$I_m = \frac{V_m}{Z} ; Z = \sqrt{R^2 + L^2 \omega^2} ; \tan(\varphi) = \frac{L\omega}{R}$$

$$i(t) = B \cdot e^{-\frac{R}{L}t} + I_m \sin(\omega t - \varphi)$$

At  $t=0$  ;

$$i(0) = 0 \rightarrow B + I_m \sin(-\varphi) = 0 \rightarrow B = I_m \sin(\varphi)$$

The final solution is :

$$i(t) = I_m \left( \sin(\varphi) e^{-\frac{R}{L}t} + \sin(\omega t - \varphi) \right)$$

**2- The waveforms of:  $i_c(t)$ ,  $V_c(t)$ , and  $V_d(t)$**

$0 \leq \omega t \leq \pi : v > 0$

D is forward-biased (D is on)

$$v_d = 0 \text{ and } V_c = v(t)$$

$\pi \leq \omega t \leq \theta$

$i(t) \neq 0$  (D keeps on for an inductive load)

$$v_d = 0 \text{ and } V_c = v(t)$$

$\theta \leq \omega t \leq 2\pi : v < 0$

D is reverse-biased (D is off)

$$v_d = v(t) \text{ and } i(t) = 0, V_c = 0$$

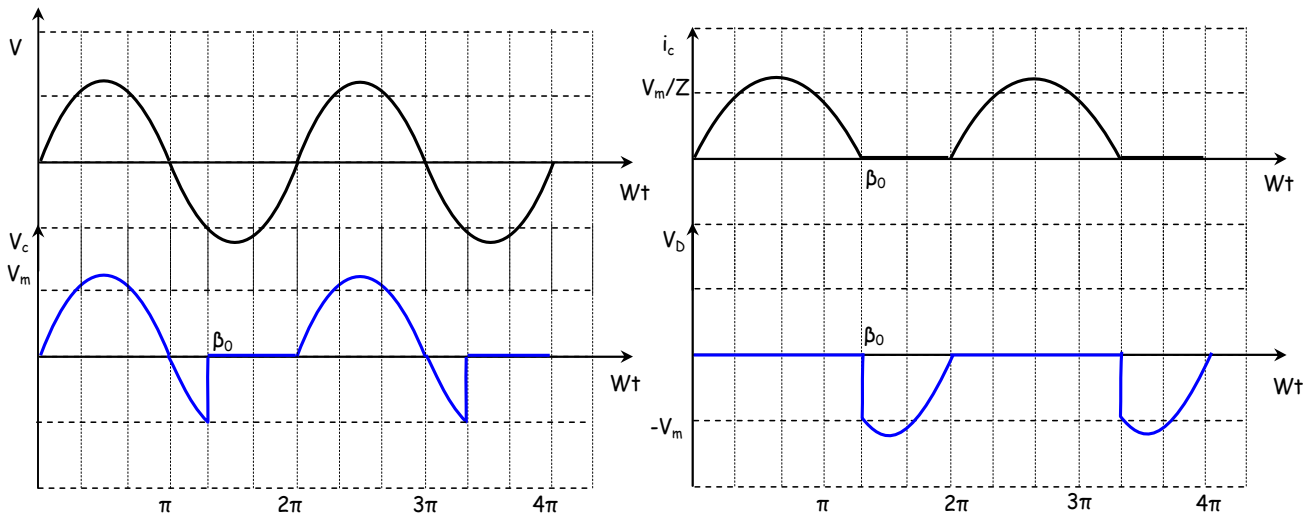

**Fig.1** Waveforms

**3-The new waveforms of:  $i_c(t)$ ,  $V_c(t)$ , and  $V_d(t)$**

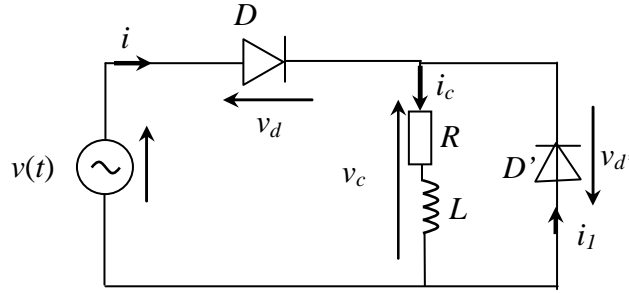

$0 \leq \omega t \leq \pi : v > 0$

D is forward-biased (D is on)

$v_d = 0$  et  $V_c = v(t)$

D' is reverse-biased (D' is off) ( $v_d' < 0$ )

$i_1 = 0 \rightarrow i = i_c$

$\pi \leq \omega t \leq \theta : v < 0$

D is reverse-biased:  $i(t)=0$

D' is forward-biased:  $i_1(t)=i_c(t)$

$v_d = v(t)$

$v_{d'} = 0$  and  $V_c = 0$

$\theta \leq \omega t \leq 2\pi : v < 0$

D off :  $i(t)=0$

D' off :  $i_1(t)=0$

$i_c(t)=0$ ,  $v_c(t)=0$  and  $v_d=v(t)$

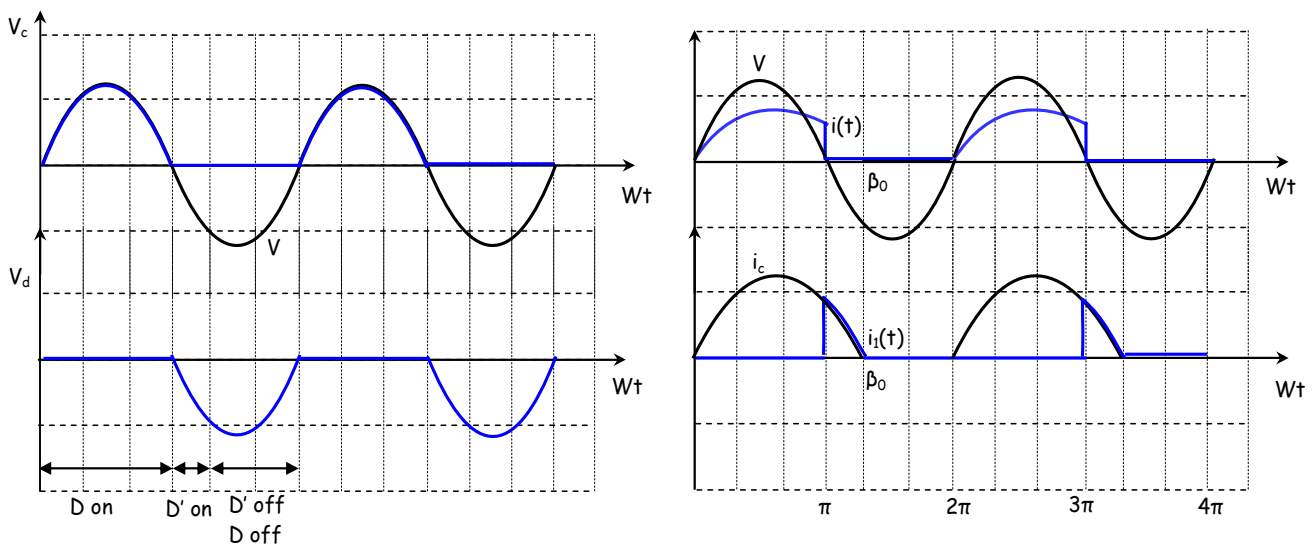

**Fig.2** Waveforms



**Solution 2-2 :**

(a)  $E=0$  V and  $R=1$   $\Omega$ :

**a1-The waveforms of:  $i_c(t)$ ,  $V_c(t)$ ,  $V_{d1}(t)$  and  $V_{d2}(t)$**

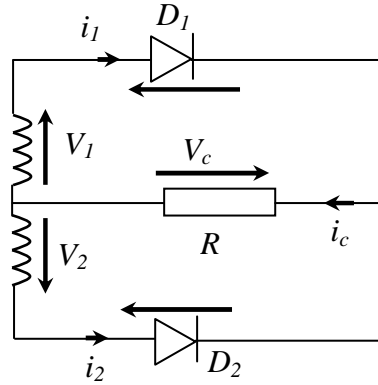

$0 \leq \omega t \leq \pi : V_1 > 0$  and  $V_2 < 0$

$D_1$  is forward-biased ( $D_1$  is on)

$D_2$  is reverse-biased ( $D_2$  is off)

$v_{d1} = 0 ; v_{d2} = V_2 - V_1 = -2V_m \sin(\omega t) ; V_c = V_1 ; i_c = \frac{V_1}{R}$

$\pi \leq \omega t \leq 2\pi : V_1 < 0$  and  $V_2 > 0$

$D_1$  is reverse-biased ( $D_1$  is off)

$D_2$  is forward-biased ( $D_2$  is on)

$v_{d2} = 0 ; v_{d1} = V_1 - V_2 = -2V_m \sin(\omega t) ; V_c = V_2 ; i_c = \frac{V_2}{R}$

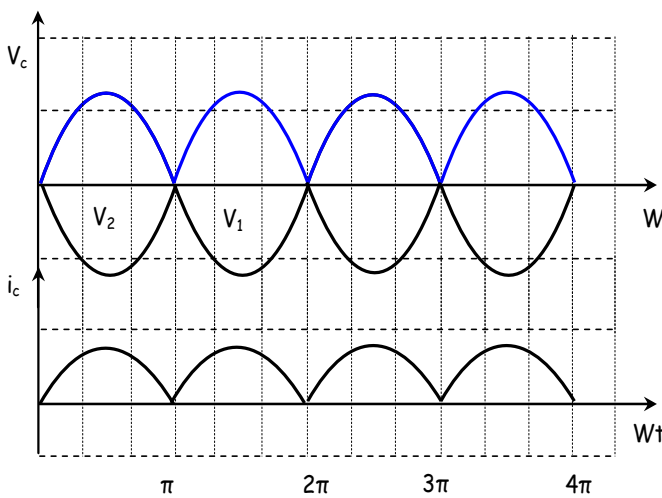

Fig.3

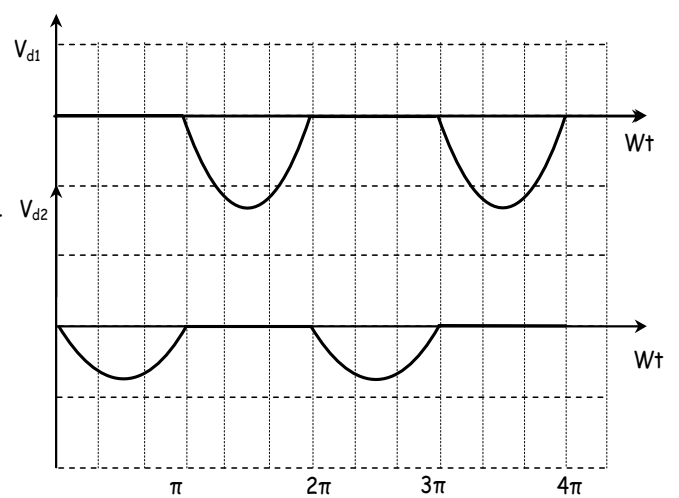

Fig.4

**a2- The power dissipated in the load:**

$$P = RI_c^2$$

$$I_c^2 = \frac{1}{T/2} \int_0^{T/2} \left(\frac{V_c}{R}\right)^2 dt = \frac{1}{\pi} \int_0^\pi \left(\frac{V_m}{R}\right)^2 \sin^2(\omega t) d\omega t = \frac{V_m^2}{2R^2}$$

$$P = R \frac{V_m^2}{2R^2} = \frac{V_m^2}{2R}$$

**(b) E=90 V and R=1 Ω:**

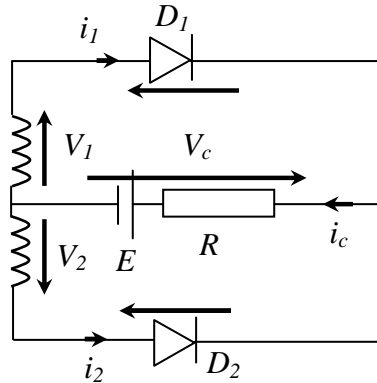

**b1-The waveforms of:  $i_c(t)$ ,  $V_c(t)$ ,  $V_{d1}(t)$  and  $V_{d2}(t)$**

$0 \leq \omega t \leq \alpha$  and  $\alpha \leq \omega t \leq \pi - \alpha$ :  $V_1 \leq E$  and  $V_2 < 0$

$D_1$  and  $D_2$  are reverse-biased ( $D_1$  and  $D_2$  are off)

$i_c = 0$  ;  $v_{d1} = V_1 - E$  ;  $v_{d2} = V_2 - E$  ;  $V_c = E$

$\alpha \leq \omega t \leq \pi - \alpha$ :  $V_1 \geq E$  and  $V_2 < 0$

$D_1$  is forward-biased ( $D_1$  is on)

$D_2$  is reverse-biased ( $D_2$  is off)

$i_c = \frac{V_c - E}{R}$  ;  $v_{d1} = 0$  ;  $v_{d2} = V_2 - E = -2V_m \sin(\omega t)$ ;  $V_c = V_1$

**b2- The power dissipated in the load:**

$$P = \frac{1}{T} \int_0^T V_c I_c dt = \frac{1}{\pi} \int_\alpha^{\pi-\alpha} V_c I_c d\omega t = \frac{1}{\pi} \int_\alpha^{\pi-\alpha} V_c \left(\frac{V_c - E}{R}\right) d\omega t$$

$$P = \frac{V_m^2}{\pi R} \left[ \frac{\pi}{2} - \alpha + \frac{1}{4} \sin(2\alpha) \right] - \frac{2V_m E}{\pi R} \cos(\alpha)$$

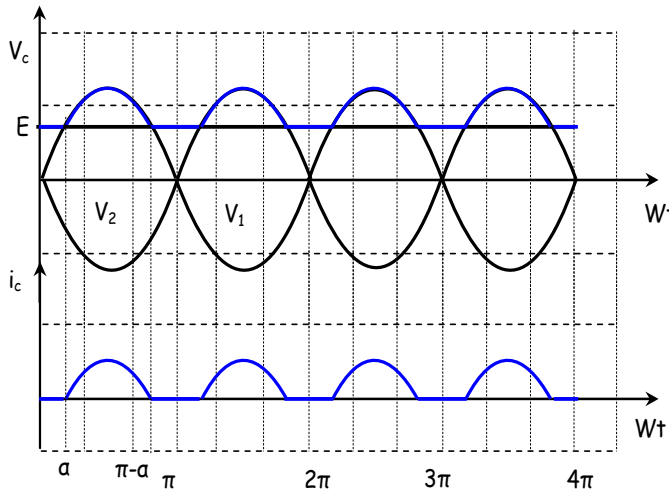

Fig.5

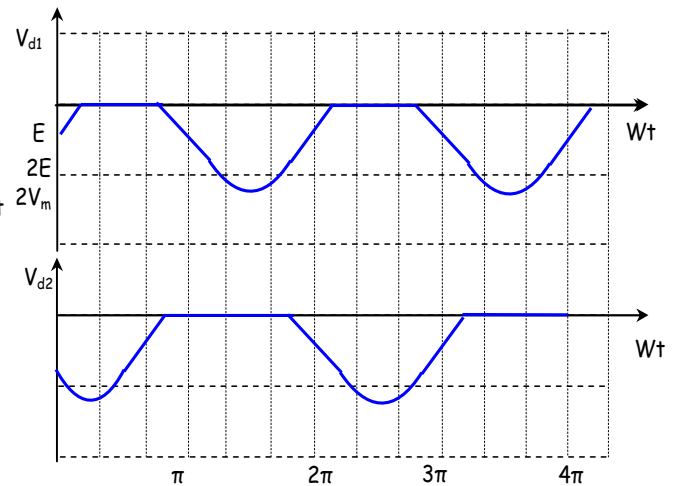

Fig.6

**Solution 2-3:**

**1- For  $\alpha=45^\circ$ , the waveforms of:  $V_c$ ,  $i_c$ , and  $V_{Th1}$  for a resistive load (R):**

$$0 \leq \omega t \leq \alpha \text{ and } \pi \leq \omega t \leq \pi + \alpha : V_1 \leq E \text{ and } V_2 < 0$$

$Th_1, Th_2, Th_3$  and  $Th_4$  are reverse-biased :  $Th_1, Th_2, Th_3$  and  $Th_4$  are off

$$i_c = 0 ; V_c = 0$$

$$v - V_{th1} - V_{th4} = 0 \rightarrow V_{th1} = \frac{v}{2}; \quad V_{th4} = \frac{v}{2}$$

$$\alpha \leq \omega t \leq \pi : V \geq 0$$

$Th_1$  and  $Th_4$  are forward-biased :  $Th_1$  and  $Th_4$  are on

$$V_{th1} = 0; \quad V_{th4} = 0$$

$$V_c = v; \quad i_c = \frac{V_c}{R}$$

$$\pi + \alpha \leq \omega t \leq 2\pi : V \leq 0$$

$Th_2$  and  $Th_3$  are forward -biased:  $Th_2$  and  $Th_3$  are on

$$V_{th2} = 0; \quad V_{th3} = 0$$

$$V_{th1} = v; \quad V_{th4} = v$$

$$V_c = -v; \quad i_c = \frac{V_c}{R}$$

**2- The power dissipated in the load:**

$$P = V_c I_c = R I_c^2$$

$$I_c^2 = \frac{1}{T} \int_0^T (i_c(t))^2 dt = \frac{1}{\pi} \int_0^\pi \left( \frac{V_m \sin(\omega t)}{R} \right)^2 d\omega t$$

$$P = \frac{V_m^2}{\pi R} \left[ \frac{\pi}{2} - \frac{\alpha}{2} + \frac{1}{4} \sin(2\alpha) \right]$$

$$\alpha = \frac{\pi}{3} \rightarrow P = 3.89 \text{ kW}$$

**3- The form factor of the rectified voltage:**

$$F = \frac{V_c}{\langle V_c \rangle}$$

$$\langle V_c \rangle = \frac{1}{T} \int_0^T V_c(t) dt = \frac{1}{\pi} \int_{\alpha}^{\pi} V_m \sin(\omega t) d\omega t = \frac{V_m}{\pi} (1 + \cos \alpha)$$

$$V_c = RI_c = R \times \sqrt{\frac{V_m^2}{\pi R^2} \left[ \frac{\pi}{2} - \frac{\alpha}{2} + \frac{1}{4} \sin(2\alpha) \right]} = \sqrt{\frac{V_m^2}{\pi} \left[ \frac{\pi}{2} - \frac{\alpha}{2} + \frac{1}{4} \sin(2\alpha) \right]}$$

$$\alpha = \frac{\pi}{3} \rightarrow F = 1.32$$

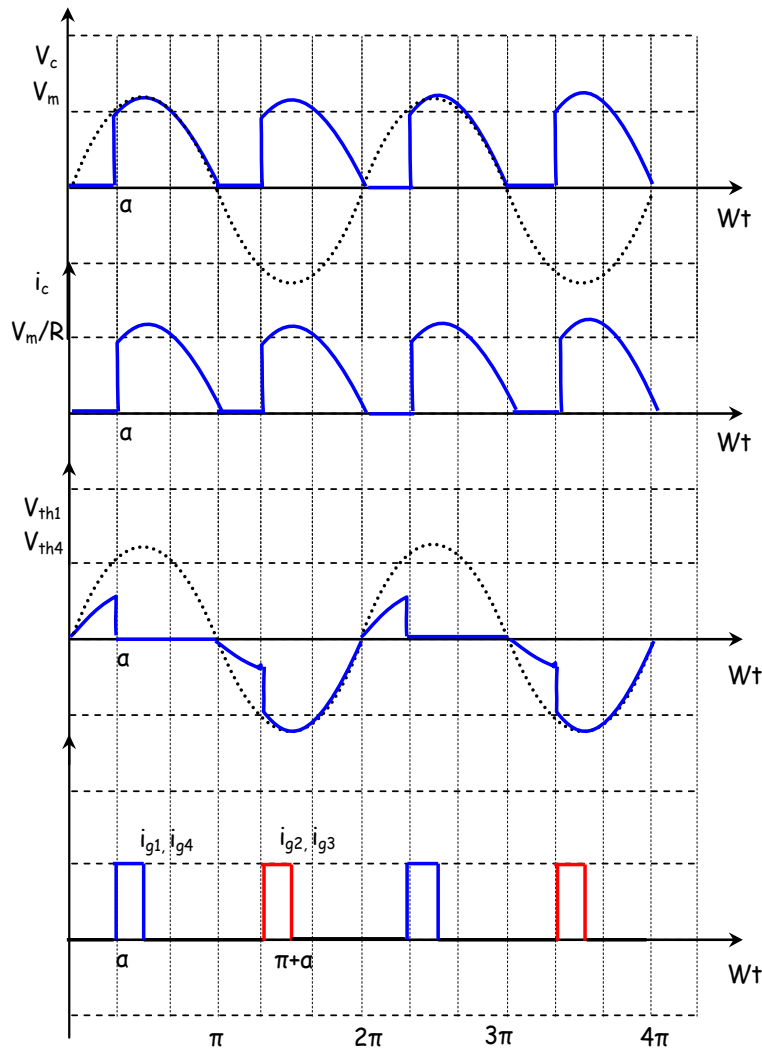

Fig.7

**4- The power factor of the converter:**

$$F_p = \frac{P}{S}$$

$$S = VI ; V = \frac{V_m}{\sqrt{2}}$$

$$I^2 = \frac{1}{T} \int_0^T (i_c(t))^2 dt = \frac{1}{2\pi} \left[ \int_{\alpha}^{\pi} \left( \frac{V_m \sin(\omega t)}{R} \right)^2 d\omega t + \int_{\pi+\alpha}^{2\pi} \left( \frac{-V_m \sin(\omega t)}{R} \right)^2 d\omega t \right]$$

$$I^2 = \frac{V_m^2}{\pi R^2} \left[ \frac{\pi}{2} - \frac{\alpha}{2} + \frac{1}{4} \sin(2\alpha) \right] \rightarrow I = \frac{V_m}{R} \sqrt{\frac{1}{\pi} \left[ \frac{\pi}{2} - \frac{\alpha}{2} + \frac{1}{4} \sin(2\alpha) \right]}$$

$$S = \frac{V_m}{\sqrt{2}} \times \frac{V_m}{R} \sqrt{\frac{1}{\pi} \left[ \frac{\pi}{2} - \frac{\alpha}{2} + \frac{1}{4} \sin(2\alpha) \right]}$$

$$\alpha = \frac{\pi}{3} \rightarrow F_p = 0.89$$

**5- For  $\alpha=45^\circ$ , the waveforms of:  $V_c$ ,  $i_c$ , and  $V_{Th1}$  for a resistive-inductive load (R, L):**

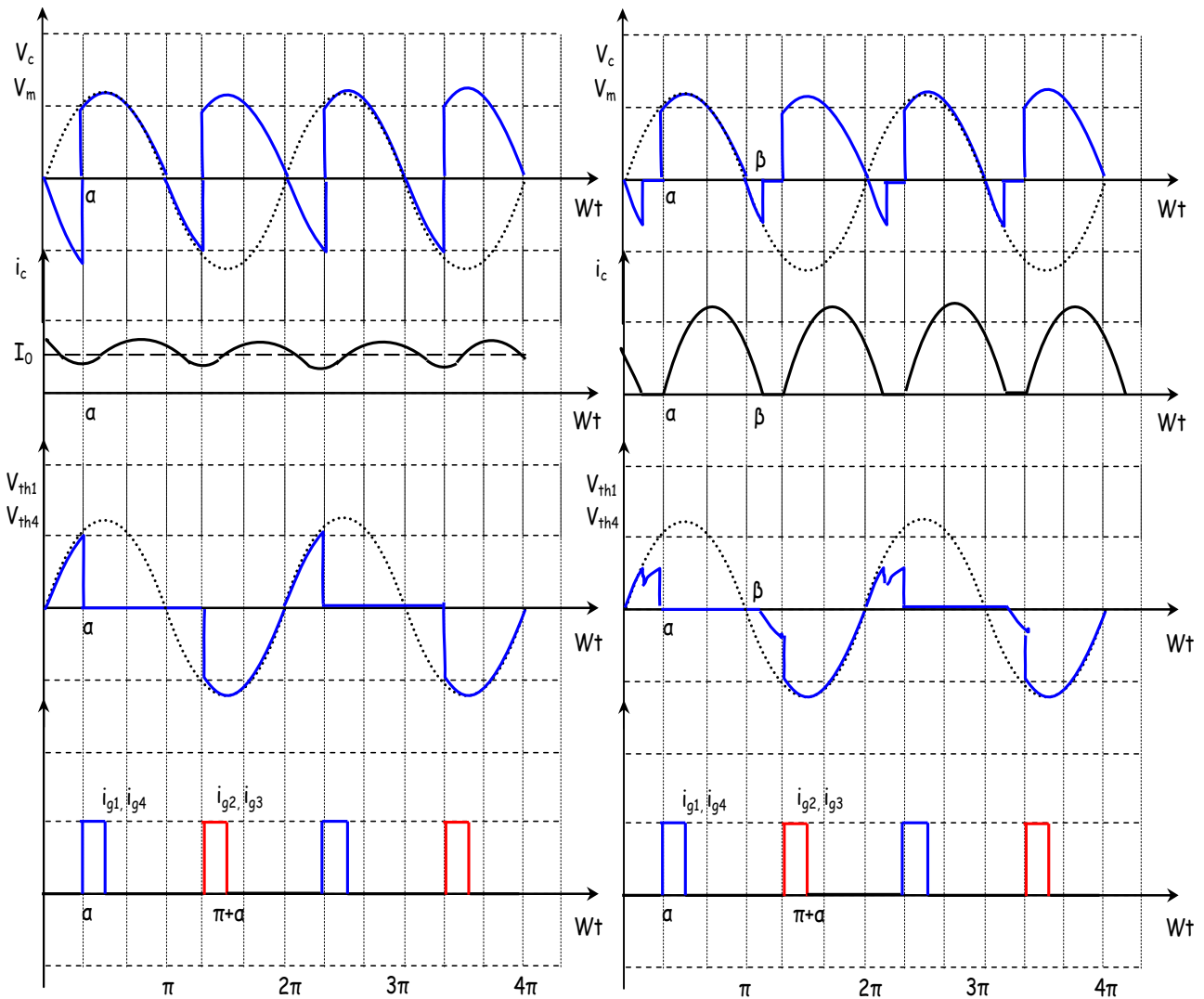

Fig.8 highly inductive load

Fig.9 inductive load

## Chapter 3

### AC-AC conversion (Dimmer)

#### 1. Introduction

AC/AC converters are power electronic devices that change the uncontrolled AC input voltage and frequency into a controlled AC output voltage and frequency. They are also known as AC voltage controllers or AC regulators.

The ac voltage controller has several practical uses including light-dimmer circuits and speed control of induction motors. The input voltage source is ac, and the output is ac (although not sinusoidal).

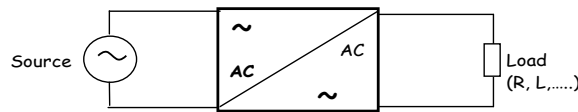

**Fig.3.1** AC-AC conversion

AC-AC converters can be categorized into three topologies:

- AC-AC voltage controller
- AC cyclo-converter
- Matrix converter

They may be single-phase or three-phase types depending on their power ratings. In this chapter we will focus only on single-phase AC/AC converters.

#### 2. Single-phase AC voltage controller:

A basic single-phase voltage controller is shown in Fig.3.2a. The electronic switches are shown as parallel thyristors (SCRs). This SCR arrangement makes it possible to have current in either direction in the load. This SCR connection is called anti-parallel or inverse parallel because the SCRs carry current in opposite directions. A triac is equivalent to the anti-parallel SCRs. Other controlled switching devices can be used instead of SCRs.

#### Resistive load (R) :

Fig.3.2b shows the voltage waveforms for a single-phase ac voltage controller with resistive load.

$$V_c(\omega t) = \begin{cases} V_m \sin(\omega t) & \text{for } \alpha < \omega t < \pi \text{ and } \alpha + \pi < \omega t < 2\pi \\ 0 & \text{otherwise} \end{cases}$$

The root mean square (RMS) value of load voltage:

$$V_{c,rms} = \sqrt{\frac{1}{\pi} \int_{\alpha}^{\pi} [V_m \sin(\omega t)]^2 dt} = \frac{V_m}{\sqrt{2}} \sqrt{1 - \frac{\alpha}{\pi} + \frac{\sin(2\alpha)}{2\pi}}$$

Note that for  $\alpha=0$ , the load voltage is a sinusoid that has the same rms value as the source. The rms current in the load and the source is:

$$I_{c,rms} = \frac{V_{c,rms}}{R}$$

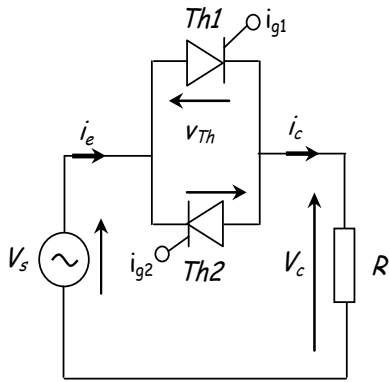

$$V_s = v_m \sin(\omega t)$$

(a)

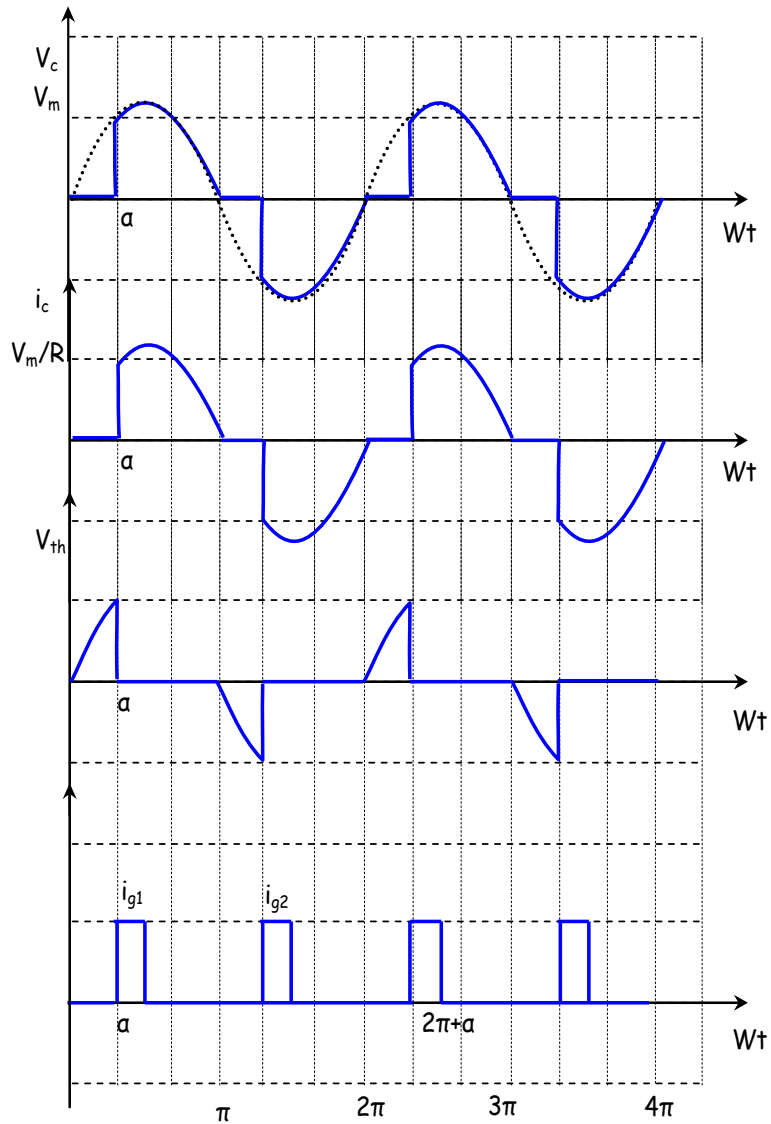

(b)

**Fig.3.2** (a) AC voltage controller with resistive load; b) Waveforms

**Inductive load (RL):**

Fig.3.3b shows a single-phase ac voltage controller with inductive load.

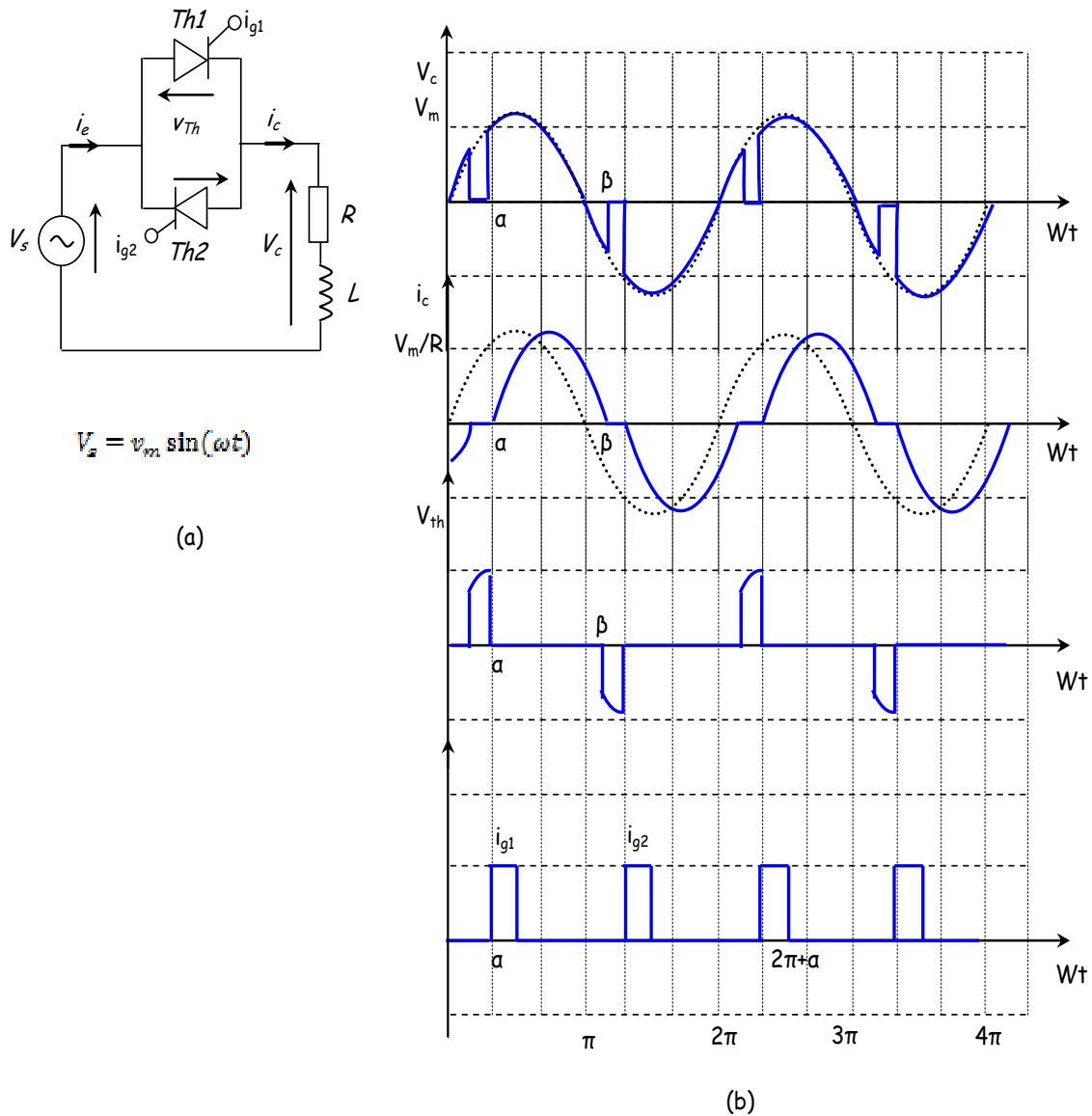

**Fig.3.3** (a) AC voltage controller with inductive load; b) Waveforms

When a gate signal is applied to Th1 at  $\omega t = \alpha$ , Kirchoff's voltage law for the circuit is expressed as:

$$V_m \sin(\omega t) = Ri_c(t) + L \frac{di_c(t)}{dt}$$

The solution for current in this equation, outlined in chapter 2, is:

$$i_c(t) = \begin{cases} \frac{V_m}{Z} [\sin(\omega t - \theta) - \sin(\alpha - \theta) e^{(\alpha - \omega t)/\omega\tau}] & \text{for } \alpha \leq \omega t \leq \beta \\ 0 & \text{otherwise} \end{cases}$$

Where  $Z = \sqrt{R^2 + (\omega L)^2}$  and  $\theta = \tan^{-1} \left( \frac{\omega L}{R} \right)$



The extinction  $\beta$  is the angle at which the current returns to zero, when  $\omega t = \beta$ ,

$$i_c(\beta) = 0 = \frac{V_m}{Z} [\sin(\beta - \theta) - \sin(\alpha - \theta) e^{(\alpha - \beta)/\omega\tau}]$$

Which must be solved numerically for  $\beta$ .

### 3. Cyclo-converters:

Cyclo-converters can convert input power at one frequency to output power at a different frequency through one-stage conversion. They can also be used to change the output amplitude of the AC supply. Usually, AC regulators provide a variable output voltage with a fixed frequency. It is also possible to achieve a variable frequency by using two stages of conversions, one AC-DC and the other DC-AC. However, cyclo-converters can eliminate the need for one or more intermediate converters. Cyclo-converters are used in high power applications driving induction and synchronous motors where precise speed control is required since they can produce a wide range of output frequencies, including very low frequencies. They are usually phase-controlled and they traditionally use thyristors due to their ease of phase commutation.

To understand the operation principles of cyclo-converters, the simplest one, single-phase to single-phase cyclo-converter will be described in this section. Figure 3.4 shows the principle circuit of a  $1\phi-1\phi$  cyclo-converter. This converter consists of back-to-back connection of two full-wave rectifier circuits. Fig.3.5 shows the operating waveforms for this converter with a resistive load.

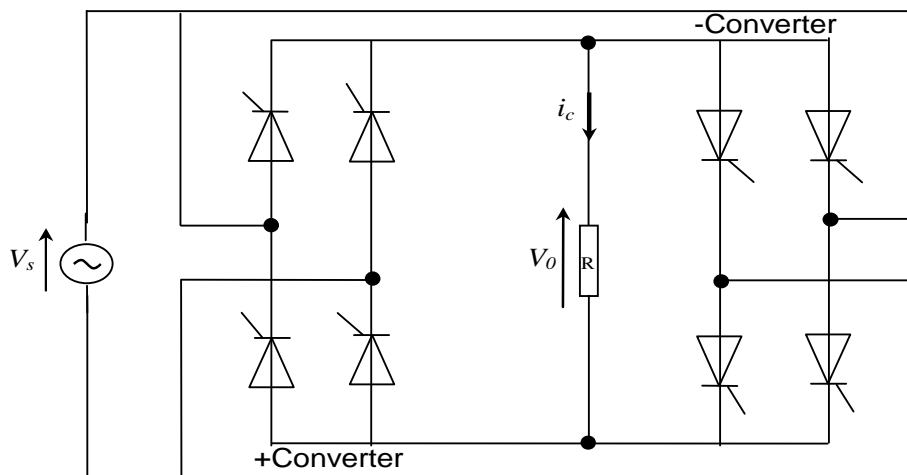

**Fig.3.4** Single-phase ( $1\phi-1\phi$ ) cyclo-converter

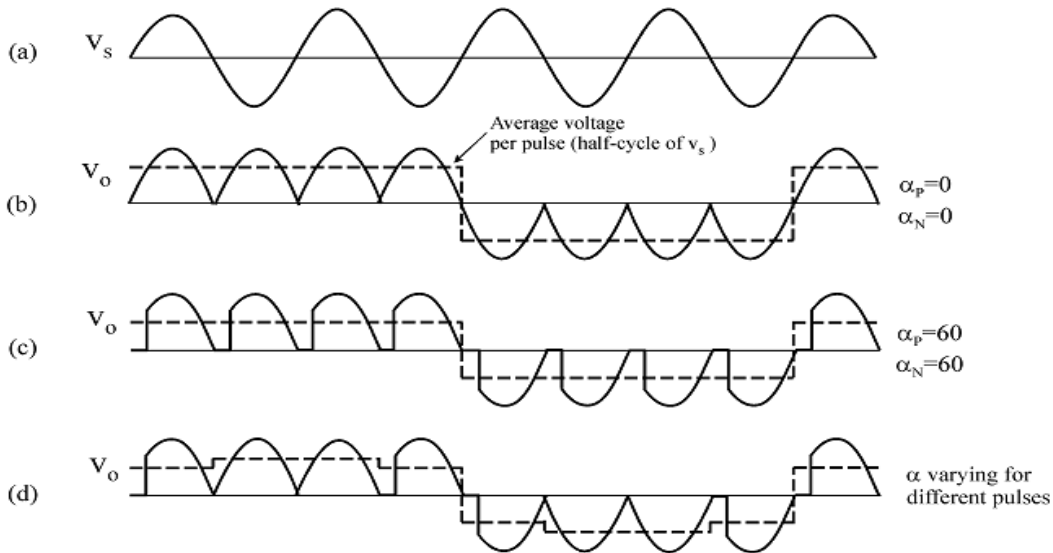

**Fig.3.5** Single-phase cyclo-converter waveforms: (a) input voltage, (b) output voltage for zero firing angle, (c) output voltage with firing angle  $\pi/3$ , (d) output voltage with varying firing angle

**Principle of operation:**

The input voltage,  $V_s$  is an ac voltage at a frequency,  $f_i$  as shown in Fig.3.5a. For easy understanding assume that all thyristors are fired at  $\alpha=0^\circ$ , i.e. thyristors act like diodes. Note that the firing angles named as  $\alpha_p$  for positive converter and  $\alpha_N$  for the negative converter.

Consider the operation of the cyclo-converter to get one-fourth of the input frequency at the output. For the first two cycles of  $V_s$ , the positive converter operates supplying current to the load. It rectifies the input voltage (Fig.3.5b). In the next two cycles, the negative converter operates supplying current to the load in the reverse direction.

The frequency of the output voltage,  $V_0$  in Fig.3.5b is 4 times less that of  $V_s$ , the input voltage, i.e.  $f_0/f_i=1/4$ . Thus, this is a step-down cyclo-converter. On the other hand, cyclo-converters that have  $f_0/f_i>1$  are called step-up cyclo-converters. Note that step-down cyclo-converters are more widely used than the step-up ones.

The frequency of  $V_0$  can be changed by varying the number of cycles the positive and the negative converters work. It can only change as integer multiples of  $f_i$  in  $1\phi-1\phi$  cyclo-converters.

With the above operation, the  $1\phi-1\phi$  cyclo-converter can only supply a certain voltage at a certain firing angle  $\alpha$ . The dc output of each rectifier is:

$$V_d = \frac{2\sqrt{2}}{\pi} V \cos \alpha$$

Where  $V$  is the input rms voltage.

Then the peak of the fundamental output voltage is:

$$V_{01} = \frac{4}{\pi} \frac{2\sqrt{2}}{\pi} V \cos \alpha$$

Thus varying  $\alpha$ , the fundamental output voltage can be controlled.

Constant  $\alpha$  operation gives a crude output waveform with rich harmonic content. The dotted lines in Fig.3.5b and c show a square wave. If the square wave can be modified to look more like a sine wave, the harmonics would be reduced. For this reason  $\alpha$  is modulated as shown in Fig.3.5d.

# Chapter 4

## DC-DC conversion (Choppers)

### 1. Introduction

A DC-DC converter, also known as DC chopper, is a static device which is used to obtain a regulated DC voltage from a constant DC voltage source. The regulation of the output voltage is ensured by power electronic components used in switching (typically transistors). Choppers are widely used in trolley cars, battery operated vehicles, traction motor control, control of large number of DC motors at variable speed. The systems employing chopper offer smooth control, high efficiency and have fast response.

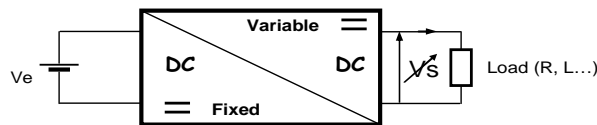
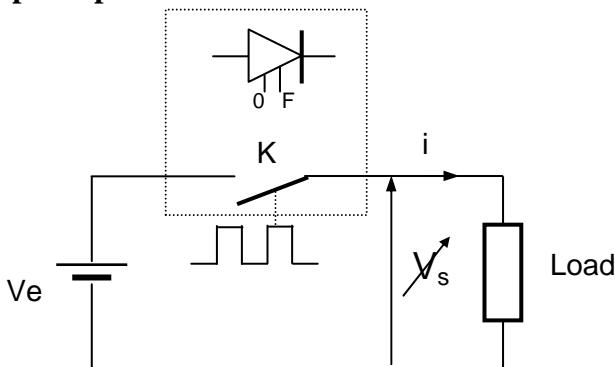

Fig.4.1 DC-DC conversion

### The principle:



A source of direct voltage  $V_e$  (such as a battery) powers a load through a switch (K) that opens and closes very rapidly.

This is a converter that uses unidirectional electronic switches with forced commutation (Transistor, GTO).

A forced commutation switch is an electronic system that, under the influence of an electrical quantity (control signal  $g$ ), allows the opening or closing of a power circuit (Figure 4.2).

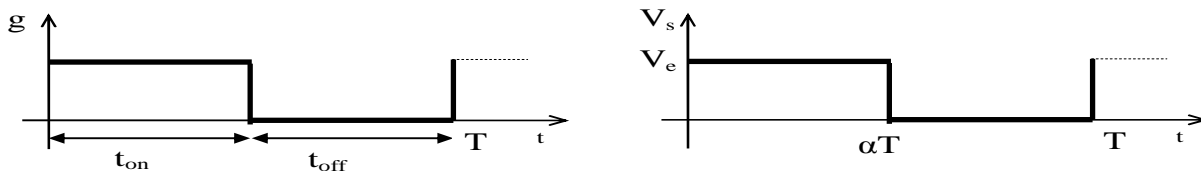

Fig.4.2 Control signal of the switch

$t_{on}$  : conduction time of switch (K)

$t_{off}$  : blocking time of switch (K)

$T=t_{on}+t_{off}$  : switching period

$f=1/T$  : frequency period

$\alpha=t_{on}/T$  : duty cycle

The switch opens and closes at a frequency ( $1/T$ ), with the ratio of the on-time to the period defined as  $\alpha$ , the duty ratio. The resulting load voltage  $V_s$  is a chopped version of the input voltage  $V_e$  as shown in Fig 4.2.

According to the ratio between the average value of the voltage across the load and that of the source, two fundamental types of choppers are found:

- 1- Step-down choppers (buck converter)
- 2- Step-up choppers (boost converter)
- 3- Buck-Boost converter

**2. Buck converter:**

A buck or step-down converter is a DC-DC switch mode power supply that is intended to buck (or lower) the input voltage of an unregulated DC supply to a stabilized lower output voltage. Buck converters are often used in lieu of traditional, non-efficient linear regulators to provide low-voltage on-board power in a variety of applications such as microprocessors, communication equipment, control systems, and more. In buck converter, the transistor switch is connected in series with the input source as shown in Fig.4.3a.

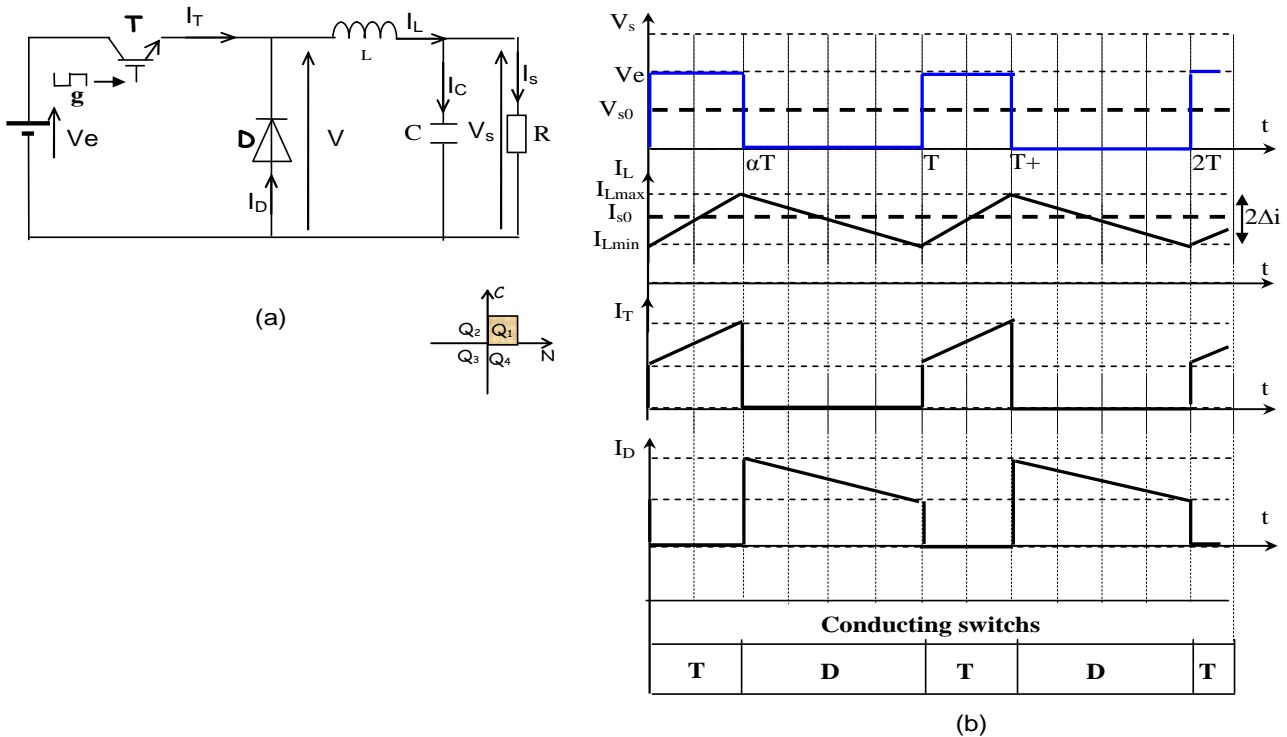

**Fig.4.3** (a) Buck converter, (b) waveforms

The operation of the converter can be deduced from the analysis of the behavior of the switch (Transistor T). Subsequently, we will focus on the continuous conduction mode ( $I_L > 0$ ), meaning that the circuit will have two states during a switching period (chopping). We will also consider the ideal circuit (without losses).

The generator imposes a voltage that remains substantially constant ( $V_e$ ). Transistor T allows the current of intensity  $I_T$  to flow to the load for a duration  $t_{on}$ . Then, the Transistor T is opened, while the current continues to flow in the load due to the inductance and the freewheeling diode.

- For  $[0, t_{on}]$ , Transistor T On and diode D Off: when the series Transistor T closes,  $V_e$  reverse biases the diode D.

$$V_T = 0, V_D = -V_e, V = V_e, V_L = V_e - V_s$$

$$I_T = I_L, I_D = 0, I_C = I_L - I_s, I_s = V_s / R$$

$$I_L = \frac{V_e - V_s}{L} t + I_L(0)$$

- For  $[t_{on}, T]$ , Transistor T Off and diode D On: when the series Transistor T opens, the continuity of current in L forces the diode D to conduct.

$$V_T = V_e, V_D = 0, V = 0, V_L = -V_s$$

$$I_T = 0, I_D = I_L, I_C = I_L - I_s, I_s = V_s / R$$

$$I_L = \frac{-V_s}{L} (t - t_{on}) + I_L(t_{on})$$

In continuous conduction (steady state):  $\langle V_L \rangle = 0$ ,  $I_L(0) = I_L(t_{on})$  and :  $I_L(0) = I_{Lmin}$ ,  $I(t_{on}) = I_{Lmax}$

$$\overline{V_L} = \frac{1}{T} \int_0^T V_L(t) dt = \frac{1}{T} \left[ \int_0^{t_{on}} (V_e - V_s) dt + \int_{t_{on}}^T (-V_s) dt \right] = 0$$

$$V_{s0} = \alpha V_e$$

-Value of the average voltage across the load:

$$V_{s0} = \alpha V_e$$

-Value of the average current in the load:

$$I_{s0} = \frac{I_T}{\alpha}$$

With  $\alpha$  : The duty cycle, knowing that  $0 \leq \alpha \leq 1$

**3. Boost converter:**

A boost or step-up converter is a DC-DC switch mode power supply that is intended to boost (or increase) the input voltage of an unregulated DC supply to a stabilized higher output voltage. Similar to a buck converter, a boost converter relies on an inductor, diode, capacitor, and power switch, but they are arranged differently (the transistor is connected in shunt to the source). The structure of the boost converter is shown in Fig.4.4a.

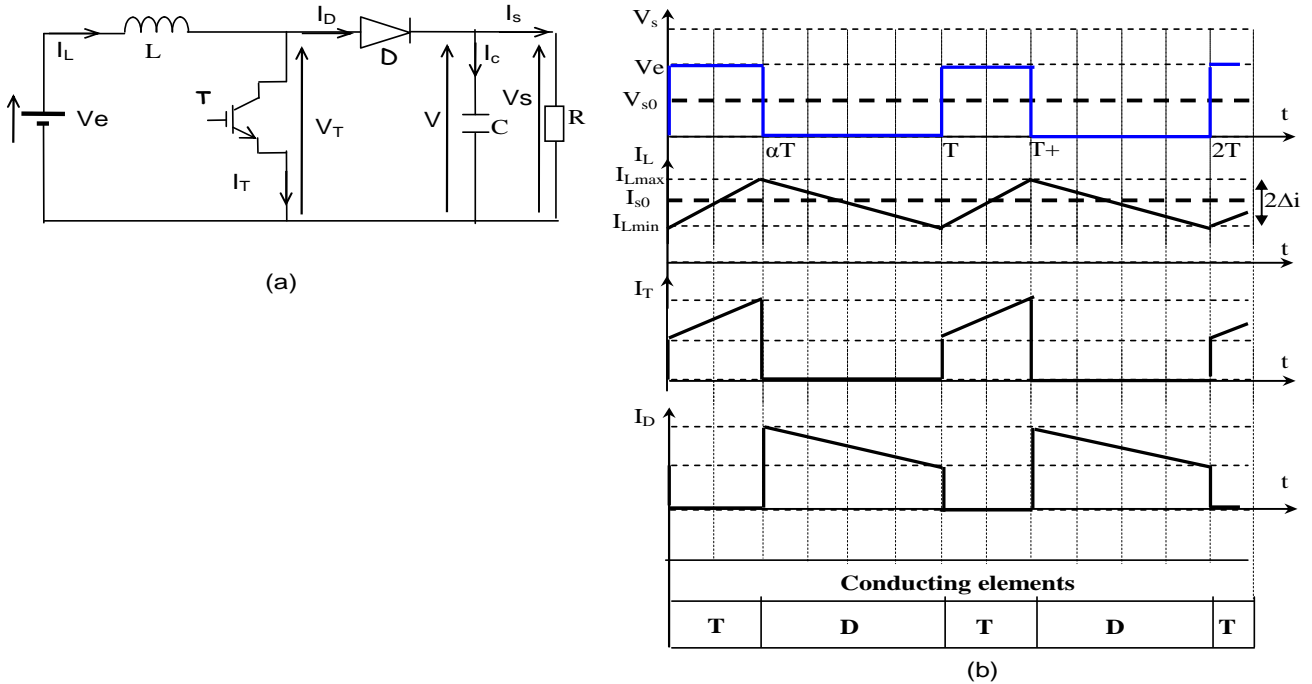

**Fig.4.4** (a) Boost converter, (b) waveforms

- For  $[0, t_{on}]$ , Transistor T On and diode D Off:

The energy delivered by the source will be stored in the inductance L. During this state, there will be a decoupling between the source and the load.

$$V_T=0, V_D=-V_s, V_L=V_e$$

$$I_T = I_L, I_D=0, I_C = -I_s, I_s=V_s/R$$

$$I_L = \frac{V_e}{L} t + I_L(0)$$

- For  $[t_{on}, T]$ , Transistor T Off and diode D On:

The blocking of T causes the conduction of D through inductive effect, thus establishing coupling between the source and the load. During this state, there will be the release of the energy stored in inductance L during the on-time in the load.

$$V_T= V_s, V_D=0, V_L=V_e-V_s$$

$$I_T = 0, I_D= I_L, I_C=I_D-I_s, I_s=V_s/R$$

$$I_L = \frac{V_e - V_s}{L} (t - t_{on}) + I_L(t_{on})$$

In continuous conduction (steady state):  $\langle V_L \rangle = 0$ ,  $I_L(0) = I_L(t_{on})$  and  $I_L(0) = I_{Lmin}$ ,  $I(t_{on}) = I_{Lmax}$

$$\overline{V_L} = \frac{1}{T} \int_0^T V_L(t) dt = \frac{1}{T} \left[ \int_0^{t_{on}} (V_e) dt + \int_{t_{on}}^T (V_e - V_s) dt \right] = 0$$

$$V_{s0} = \frac{1}{1 - \alpha} V_e$$

-Value of the average voltage across the load:

$$V_{s0} = \frac{1}{1 - \alpha} V_e$$

-Average value of the current in the load:

$$I_{s0} = (1 - \alpha) I_L$$

$\alpha$  : The duty cycle, knowing that  $0 \leq \alpha \leq 1$

**4. Buck-Boost converter:**

A buck-boost converter can supply a regulated DC output voltage from a power source delivering a voltage either below or above the regulated output voltage. In the buck-boost converter, the transistor switch alternately connects the inductor across the power input and output voltages. This converter inverts the polarity of the voltage and can either increase or decrease the voltage magnitude. The structure of the buck-boost converter is shown in Fig.4.5a.

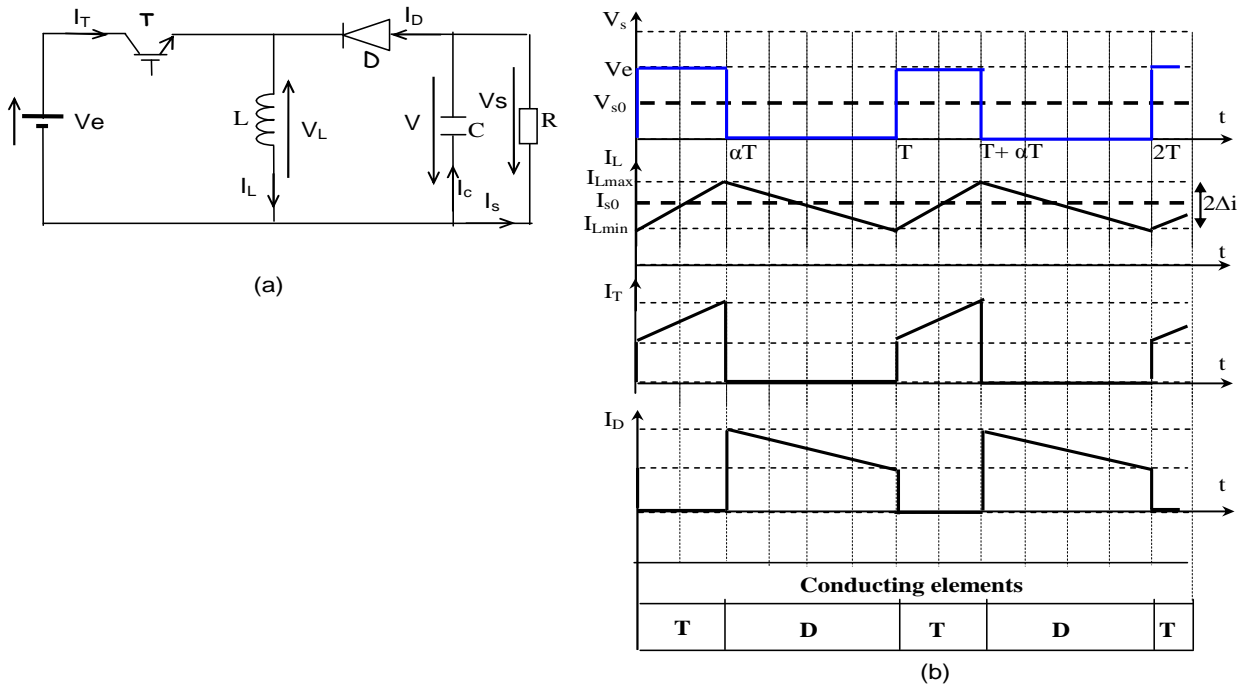

**Fig.4.5** (a) Buck-Boost converter, (b) waveforms

The conversion ratio is:  $V_{s0} = \frac{-\alpha}{1 - \alpha} V_e$



- For  $[0, t_{on}]$ , Transistor T On and diode D Off:

The energy delivered by the source will be stored in the inductance L. During this state, there will be a decoupling between the source and the load.

$$V_T=0, V_D=-V_L-V_s, V_L=V_e$$

$$I_L = I_T, I_D=0, I_C= -I_s, I_s=V_s/R$$

$$I_L = \frac{V_e}{L}t + I_L(0)$$

- For  $[t_{on}, T]$ , Transistor T Off and diode D On:

The blocking of T causes the conduction of D through inductive effect, thus establishing coupling between the inductor and the load. During this state, there will be the release of the energy stored in inductance L during the on-time in the load.

$$V_T= V_e + V_s, V_D=0, V_L=-V_s$$

$$I_T = 0, I_D= I_L, I_C=I_D-I_s, I_s=V_s/R$$

$$I_L = \frac{-V_s}{L}(t - t_{on}) + I_L(t_{on})$$

In continuous conduction (steady state):  $\langle V_L \rangle = 0$ ,  $I_L(0) = I_L(t_{on})$  and :  $I_L(0) = I_{Lmin}$ ,  $I(t_{on}) = I_{Lmax}$

$$\overline{V_L} = \frac{1}{T} \int_0^T V_L(t) dt = \frac{1}{T} \left[ \int_0^{t_{on}} (V_e) dt + \int_{t_{on}}^T (-V_s) dt \right] = 0$$

$$V_{s0} = \frac{\alpha}{1 - \alpha} V_e$$

-Value of the average voltage across the load:

$$V_{s0} = \frac{\alpha}{1 - \alpha} V_e$$

-Average value of the current in the load:

$$I_{s0} = \frac{\alpha}{R(1 - \alpha)} V_e$$

$\alpha$  : The duty cycle, knowing that  $0 \leq \alpha \leq 1$

If  $\alpha < 1/2$ , then  $V_{s0} < V_e$  (Buck operation of the converter)

If  $\alpha > 1/2$ , then  $V_{s0} > V_e$  (Boost operation of the converter)

**5. Problems:****Problem 5-1 :**

Buck converter: The supply voltage of the buck converter is constant and equals  $V_s=210\text{V}$ .  $D$  is an ideal diode.  $K$  is a perfect controlled switch.  $\alpha$  is the control duty cycle of this converter, and  $T$  ( $T=0.1\text{ms}$ ) is the operating period.

- For  $t \in [0 ; \alpha T]$ ,  $K$  is closed
- For  $t \in [\alpha T ; T]$ ,  $K$  is open

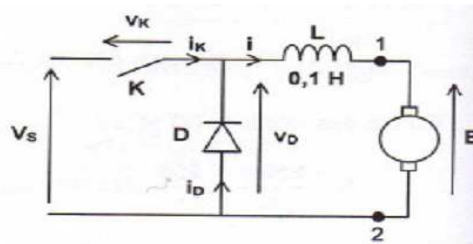

We consider that the voltage across the motor is equal to its electromotive force (fem)  $E$ , which is proportional to the rotational speed of the motor:  $E=k N$  with  $k=5.25 \times 10^{-2} \text{ V (rpm)}$ . We assume that the current intensity  $i$  never becomes zero and varies linearly between the minimum and maximum values,  $I_{\min}$  and  $I_{\max}$ .

- 1) Determine the expression for  $i(t)$  for  $t \in [0 ; \alpha T]$  and then for  $t \in [\alpha T ; T]$ .
- 2) Plot the waveforms of  $v_D(t)$  and  $i(t)$  over a duration of  $2T$ .
- 3) Express the average value of the voltage  $v_D(t)$  as a function of  $\alpha$  and  $V_s$ . Deduce the relationship between  $E$ ,  $\alpha$ , and  $V_s$ .
- 4) Express the current ripple  $\Delta i = I_{\max} - I_{\min}$  as a function of  $\alpha$ ,  $V_s$ ,  $L$ , and  $T$ .
- 5) Plot the waveform of  $\Delta i$  as a function of  $\alpha$ .
- 6) For what value of  $\alpha$  is the current ripple maximal? Calculate  $(\Delta i)_{\max}$ .
- 7) Determine the value of  $\alpha$  that adjusts the rotational speed to  $N = 1000 \text{ rpm}$ .
- 8) Plot the waveforms of  $i_D(t)$  and  $i_k(t)$

**Problem 5-2:**

Consider a buck chopper circuit characterized by  $v_e=28V$ ,  $f_c=50$  kHz.

a- For what values of  $R$  and  $\alpha$  will the load absorb power  $P=25W$  under an average current  $I_s=1.5A$ .

b- Calculate the values of  $L$  and  $C$  for current and voltage ripples  $\Delta I_L=0.1A$ , and  $\Delta V_s=0.5V$ .

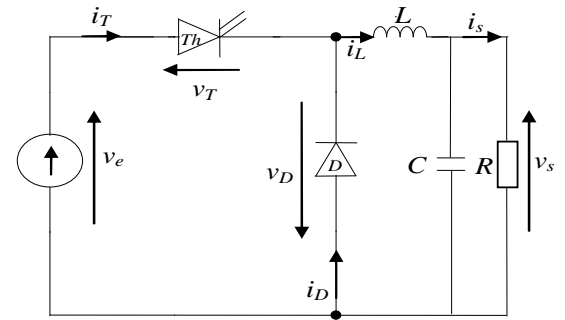

Note:

- The circuit is assumed to be ideal and operates in continuous mode.
- The capacitance is assumed to be sufficiently large such that:  $\Delta X_i = X_{i\max} - X_{i\min}$

**Problem 5-3:**

In this exercise, unless otherwise indicated, conduction will be assumed to be continuous: The current in the inductance never becomes zero. The output voltage will be assumed constant.

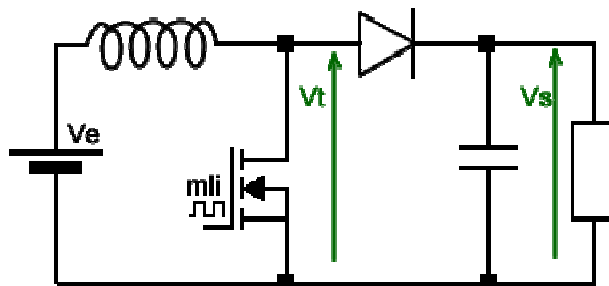

1. The voltage  $V_e$  is 200V, and we desire an output voltage  $V_s$  of 500V. Determine the necessary duty cycle  $\alpha$ .
2. The switching frequency is  $f_c=100kHz$ , and the value of the inductance is  $L=1mH$ . Calculate the current ripple in the inductance  $\Delta I_L$ .

**6. Solutions:**

**Solution 6-1**

1) The expression of  $i(t)$ :

$$t \in [0 ; \alpha T]: v_s(t) = L \frac{di}{dt} + E \rightarrow \frac{di}{dt} = \frac{v_s - E}{L} \text{ et } i(t) = I_{min} + \left(\frac{v_s - E}{L}\right) t \dots \dots \dots (1)$$

$$t \in [\alpha T ; T]: 0 = L \frac{di}{dt} + E \rightarrow \frac{di}{dt} = \frac{-E}{L} \text{ et } i(t) = I_{max} + \left(\frac{-E}{L}\right) (t - \alpha T) \dots \dots \dots (2)$$

2) Plot of  $v_D(t)$  and  $i(t)$  over a duration of  $2T$ :

The waveforms are plotted in **Fig.1**.

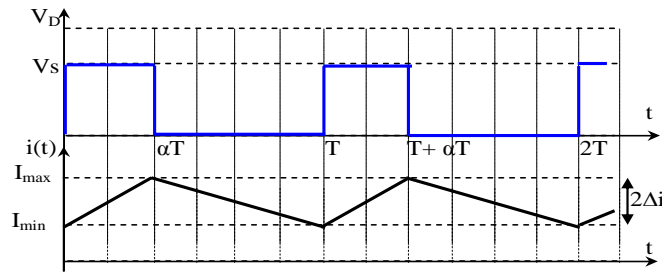

**Fig.1**

3) The average value of the voltage  $v_D(t)$ :

$$\overline{v_D} = \alpha v_s$$

$$\overline{v_L} = 0 \rightarrow \overline{v_D} = E = \alpha v_s$$

4) The current ripple  $\Delta i$ :

$$\Delta i = I_{max} - I_{min}$$

$$\text{From (1): } i(\alpha T) = I_{max} = I_{min} + \left(\frac{v_s - E}{L}\right) \alpha T$$

$$\Delta i = I_{max} - I_{min} = \left(\frac{v_s - E}{L}\right) \alpha T = \left(\frac{v_s - \alpha v_s}{L}\right) \alpha T = \frac{v_s(1 - \alpha)\alpha}{Lf}$$

5) Plot the waveform of  $\Delta i$  as a function of  $\alpha$ :

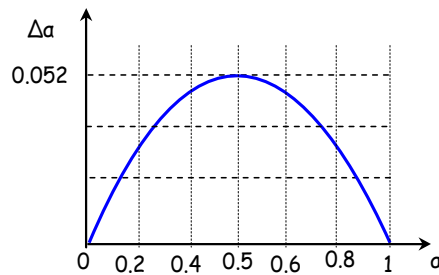

**Fig.2**

6) For what value of  $\alpha$  is the current ripple maximal? Calculate  $(\Delta i)_{max}$ :

$$\alpha = \frac{1}{2} \rightarrow \Delta i = \Delta i_{max} = \frac{v_s T}{4L} = 52.5 \text{ mA}$$

7) The value of  $\alpha$  that adjusts the rotational speed to  $N = 1000$  rpm:

$$E = k.N \rightarrow \alpha v_s = k.N \rightarrow \alpha = \frac{kN}{v_s} = \frac{5.25 \times 10^{-2} \times 10^3}{210} = 0.25$$

8) Plot of  $i_D(t)$  and  $i_k(t)$ :

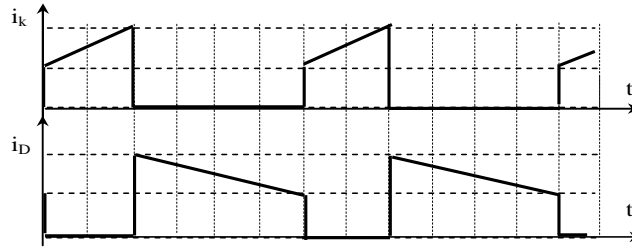

Fig.3

### Solution 6-2

a- Values of  $R$  and  $\alpha$ :

Given that the converter is ideal and the capacity is large enough, then:

$$P = V_e I_e = V_s I_s \rightarrow I_e = \frac{P}{V_e} = \frac{25}{28} = 0.9A$$

$$\frac{I_s}{I_e} = \frac{1}{\alpha} \rightarrow \alpha = \frac{I_e}{I_s} = \frac{0.9}{1.5} = 0.6$$

$$V_s = R I_s \rightarrow R = \frac{V_s}{I_s} \rightarrow R = \frac{\alpha V_e}{I_s} = \frac{0.6 \times 28}{1.5} = 11.2\Omega$$

b- The values of  $L$  and  $C$ :

$$t \in [0; \alpha T]: v_L = L \frac{di_L}{dt} = V_e - V_s \rightarrow \frac{\Delta i_L}{\Delta t} = \frac{V_e - V_s}{L} \rightarrow \frac{\Delta i_L}{\alpha T} = \frac{V_e - V_s}{L} \rightarrow L = \left( \frac{V_e - V_s}{\Delta i_L} \right) \alpha T = 1.34 \text{ mH}$$

$$|+\Delta Q| = |-\Delta Q|$$

$$Q = C.V \rightarrow \Delta Q = C \Delta V \rightarrow C = \frac{\Delta Q}{\Delta V}$$

$$\Delta Q = \frac{X.Y}{2}, \quad X = \frac{T}{2}, \quad Y = \frac{\Delta i_L}{2}$$

$$\Delta Q = \frac{\Delta i_L T}{8} \rightarrow \Delta Q = \frac{\alpha (V_e - V_s)}{8 f^2 L} = 250 \mu c$$

$$C = \frac{\Delta Q}{\Delta V} = \frac{250 \mu c}{0.5 V} = 500 \mu F$$

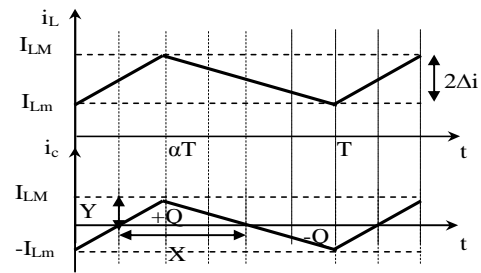

Fig.4

**Solution 6-3**

1) The necessary duty cycle  $\alpha$ :

$$V_s = \frac{V_e}{1 - \alpha} \rightarrow \alpha = 1 - \frac{V_e}{V_s} = 0.06$$

2) The current ripple in the inductance  $\Delta I_L$ :

$$\Delta i_L = V_L \frac{\Delta t}{L}$$

$$t \in [0 ; \alpha T]: \Delta i_L = \frac{V_s - V_e}{L} \Delta t = \frac{300}{10^{-3}} 0.06 \cdot 10^{-5} = 1.2A$$

$$t \in [\alpha T ; T]: \Delta i_L = \frac{-V_e}{L} \Delta t = \frac{-200}{10^{-3}} 0.04 \cdot 10^{-5} = -1.2A$$

## Chapter 5

### DC-AC conversion (Inverters)

#### 1. Introduction

The dc-ac converter, also known as the inverter, is a static converter that converts dc power to ac power at desired output voltage and frequency. The dc power input to the inverter is obtained from an existing power supply network or from a rotating alternator through a rectifier or a battery, fuel cell, photovoltaic array or magneto hydrodynamic generator. The filter capacitor across the input terminals of the inverter provides a constant dc link voltage. The inverter therefore is an adjustable-frequency voltage source. The configuration of ac to dc converter and dc to ac inverter is called a dc link converter.

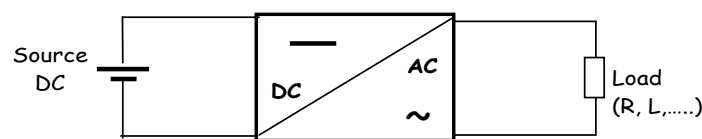

**Fig.5.1** DC-AC conversion

We will distinguish three fundamental structures:

- Voltage inverters (the direct current source is a voltage source);
- Current inverters or current switches (the direct current source is a current source);
- Resonant inverters (voltage resonance, current resonance).

A standard single-phase voltage or current source inverter can be in the half bridge or full-bridge configuration. The single-phase units can be joined to have three-phase or multiphase topologies. Some industrial applications of inverters are:

- Uninterruptible Power Supplies (UPS). They serve as backup power sources. The direct current source is usually a battery pack. The frequency and amplitude of the output voltage are fixed.
- Variable speed drives for alternating current machines. The direct current source is obtained by rectifying the network. The frequency and amplitude of the output voltage are controlled.

In this chapter, single-phase inverters, three-phase inverters and their operating principles are analyzed in detail. The concept of Pulse Width Modulation (PWM) for inverters is described with application to single and three phase inverters. Finally the simulation results for a single-phase inverter using the PWM strategy described are presented.

**2. Single-phase voltage inverters**

**2.1 Half-Bridge single-phase inverter:**

The half-bridge single-phase inverter of Fig.5.2 is the basic circuit to convert dc to ac. A single voltage source is used, and the midpoint is created by connecting two capacitors in series with high values. Switches S1 and S2 are made up of GTO thyristors or transistors operating in forced commutation (controlled for both opening and closing).

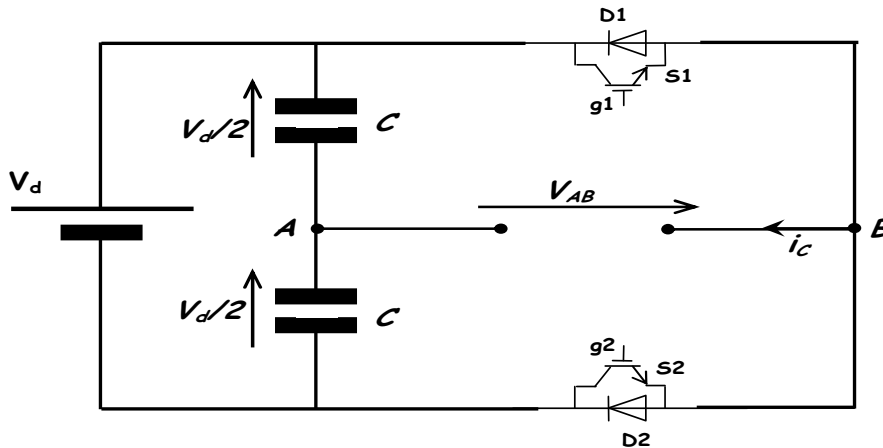

**Fig.5.2** Single-phase half-bridge inverter

Note that S1 and S2 should not be closed or opened at the same time. Otherwise, a short circuit would exist across the dc source and opened load, respectively. We assume that switch S1 is closed during the first half-cycle, making the voltage  $V_{AB}$  equal to  $+V_d$ , and switch S2 is closed during the other half-cycle, making  $u_c$  equal to  $-V_d$ . This control is called symmetrical control. There are other types of control, such as phase-shifted control and PWM control.

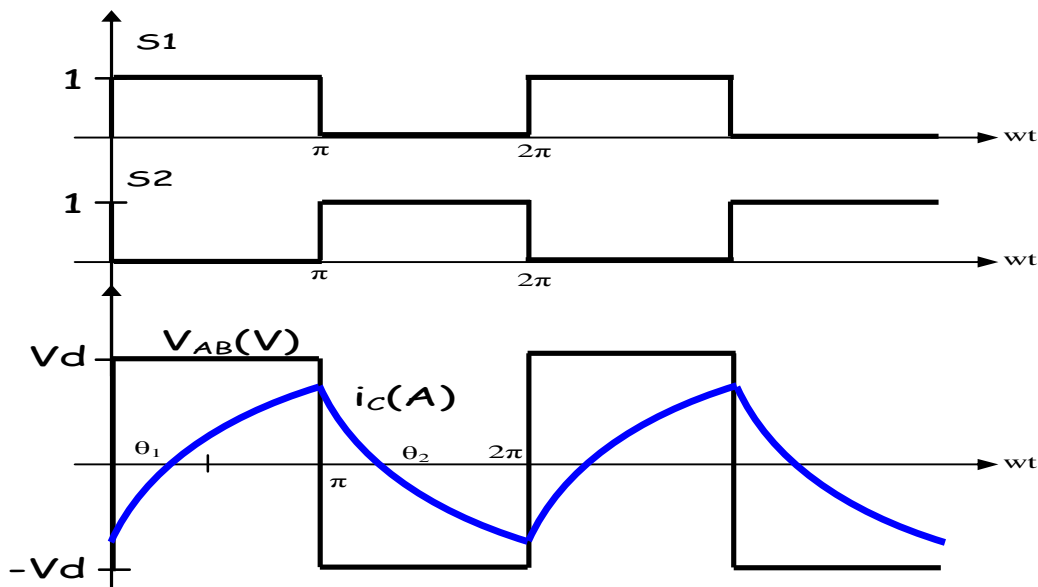
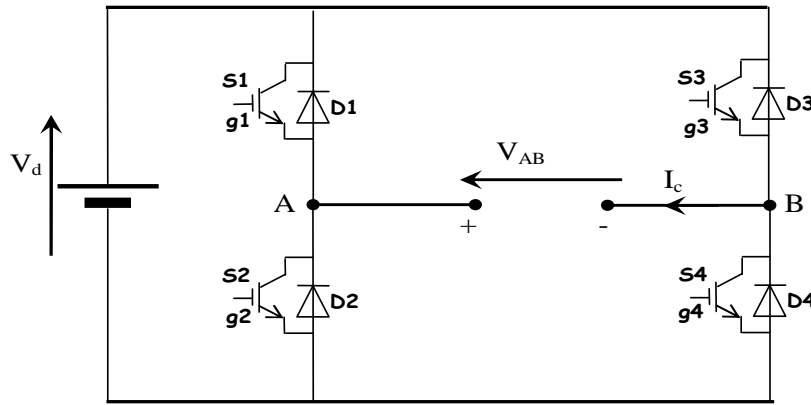

**Fig.5.3** Waveforms of voltage and current



**2.2 Single-phase Full-Bridge inverter:**

For this converter shown in Fig.5.4, the ac output voltage is synthesized from a dc input by closing and opening four switches in an appropriate sequence. The output voltage  $V_{AB}$  can be  $+V_d$ ,  $-V_d$ , or zero, depending on which switches are closed. Note that  $S_1$  and  $S_2$  should not be closed at the same time, nor should  $S_3$  and  $S_4$ .

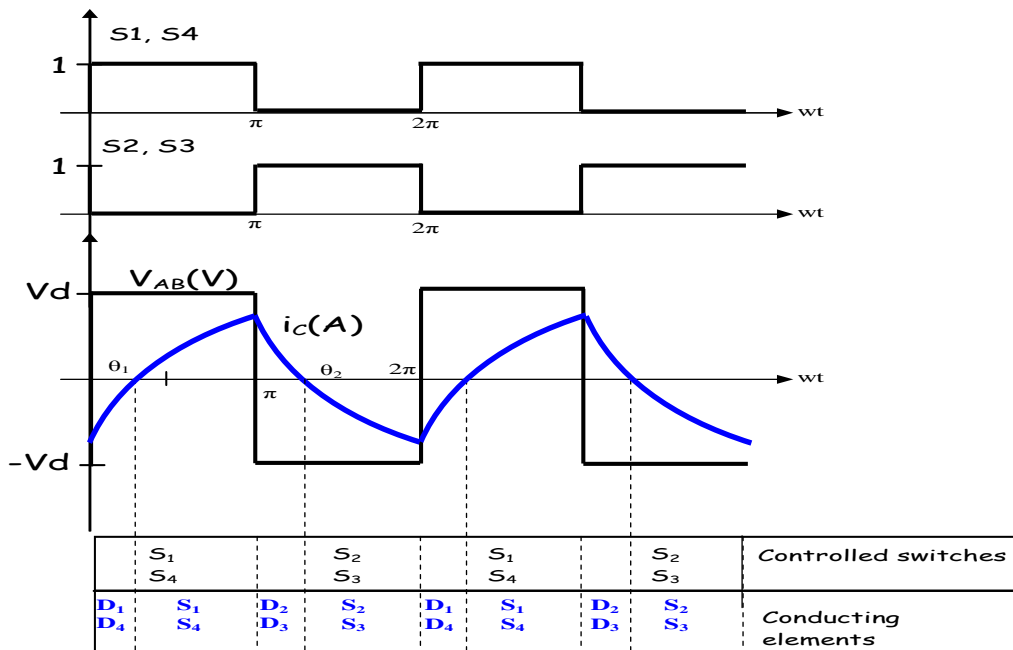

**Fig.5.4** Single-phase full-bridge inverter

**2.3 Different types of control for the single-phase inverter:**

**a) Symmetrical control (full wave):**

This control involves closing switches  $S_1$  and  $S_4$  of a single-phase inverter during one half-cycle and then closing  $S_2$  and  $S_3$  during the second half-cycle. The periodic switching of the load voltage between  $+V_d$  and  $-V_d$  produces a square wave voltage across the load. The current waveform in the load depends on the load components. For inductive load, the current waveform is shown in Fig.5.5.



**Fig.5.5** Waveforms of voltage and current

The ac frequency is controlled by the rate at which the switches open and close. E can control parameters of the ac voltage (its rms value or the amplitude of its fundamental component, for instance) by varying the dc input voltage. This requires a complicated dc system that might, for instance, use a phase-controlled rectifier or a dc/dc converter. An alternative technique is to use a third switch state during which  $V_{AB}=0$  to create the waveform of Fig.5.6. This state is obtained by using the phase-shifted control technique.

**b) Phase-shifted control:**

This control allows modifying the characteristics of the output voltage, especially the effective value of its fundamental, without having to intervene at the level of the supply voltage  $V_d$ . The control intervals remain equal to half a cycle but are shifted as indicated below.

**Output waveforms:**

It is sufficient to shift the control of the switches by an angle  $\delta$  (phase-shift angle) for this purpose.

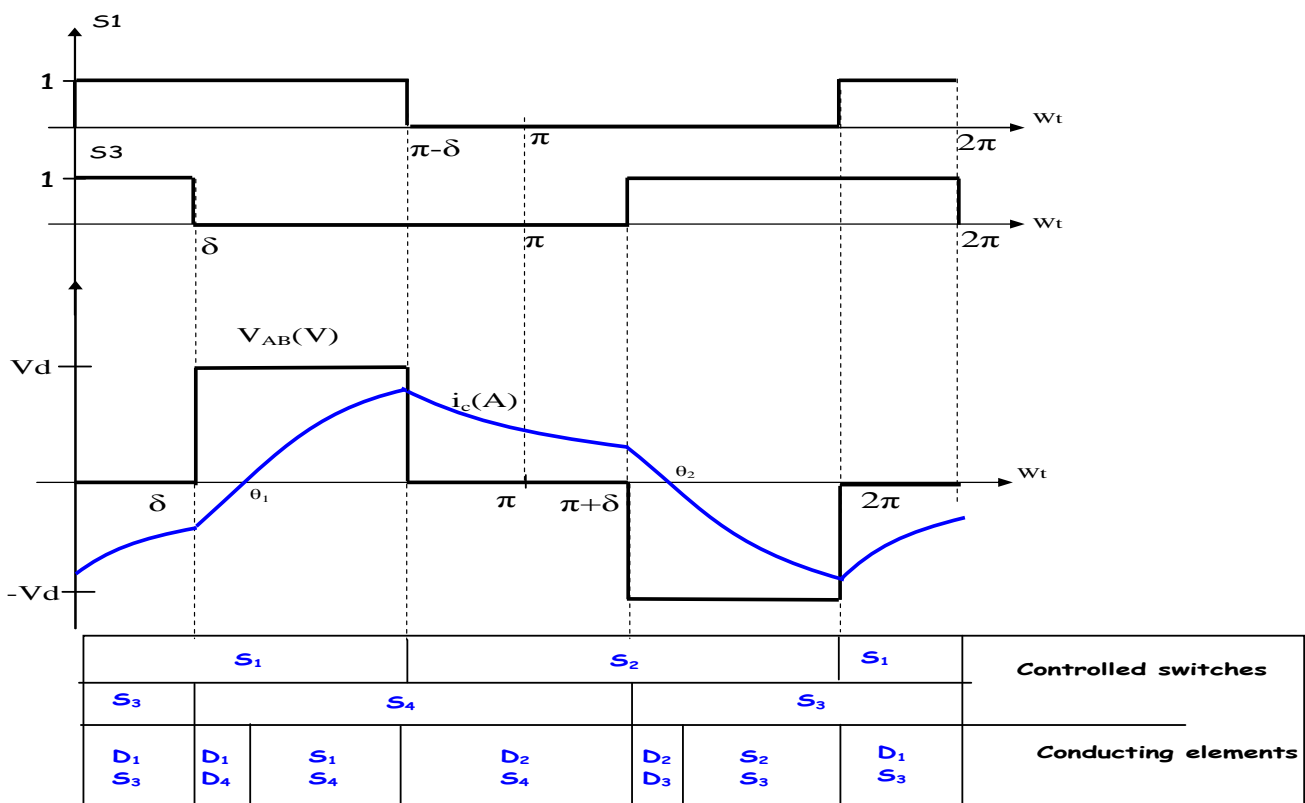

**Fig.5.7** Waveforms of voltages and currents

**Root mean square of the voltage:**

As a function of our controlling variable  $\delta$ , the effective value is given by:  $V_{AB} = V_d \sqrt{1 - \frac{2\delta}{\pi}}$

By varying  $\delta$ , we can change the effective value of the voltage provided by the inverter.

Note: The two types of control we have seen so far share a common feature: each semiconductor is activated only once per period (period of the output voltage = period of the control). For this reason, these methods are sometimes called fundamental pulsation control.

### c) Pulse width modulation (PWM) control:

The most efficient method for adjusting the output voltage amplitude and frequency of an inverter is by pulse-width modulation control. In this method, a fixed dc input voltage is given to the inverter and a controlled ac output voltage is obtained by adjusting the on and off periods of the inverter components.

The advantages of PWM techniques are:

- (i) The output voltage control with this method can be obtained without any additional components.
- (ii) Allows the generation of a load current very close to a sine wave.
- (iii) PWM pushes the lower order harmonics towards higher frequencies, making their filtering easier.
- (iv) Enables the adjustment of the amplitude and frequency of the output voltage.

The output voltage and frequency of a single-phase inverter can be controlled using one of the two forms of PWM, termed:

-Bipolar

-Unipolar

### General principle of PWM

In order to produce sinusoidal output voltage at desired frequency a sinusoidal control signal at desired frequency is compared with a triangular waveform as shown in Fig.5.8.

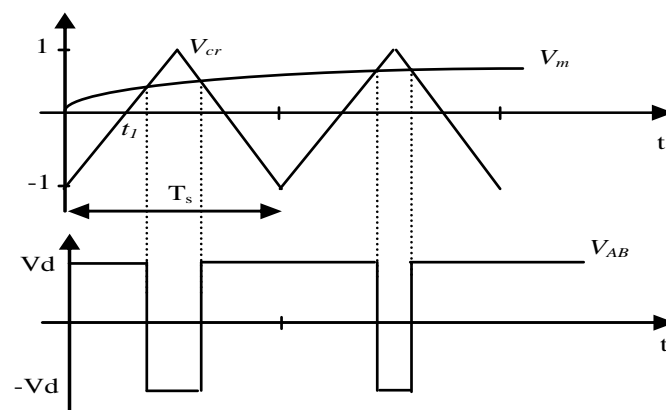

**Fig.5.8** Sinusoidal PWM

The instants of closing and opening of the "switches" are determined by the intersections of the modulating waveform  $V_m$  with a frequency  $f_m$ , representing the desired output voltage, and the triangular (or carrier) modulation waveform  $V_{cr}$ , ranging between -1 and 1, with a frequency  $f_{cr}$  significantly higher than  $f_m$ .

Two parameters are generally used to characterize sinusoidal PWM modulation:

- Frequency modulation ratio  $m_f$ , equal to the ratio of the modulation frequency to the reference frequency

$$m_f = \frac{f_{cr}}{f_m}$$

- Amplitude modulation ratio  $m_a$ , equal to the ratio of the reference amplitude to the peak value of the modulation waveform (carrier)

$$m_a = \frac{\hat{V}_m}{\hat{V}_{cr}}$$

The first one indicates the number of pulses that the voltage  $V_{AB}$  contains per period of the reference waveform. The second one, when multiplied by  $V_d$ , provides the amplitude of the desired output voltage.

**Bipolar PWM**

For single-phase bridge inverter, based on bipolar PWM, the turn on and turn off instants of switches are determined by comparing two signals:

- a high-frequency triangular carrier signal  $V_{cr}$ .
- a sinusoidal modulating wave signal  $V_m$  with variable amplitude and frequency  $f_m$ .

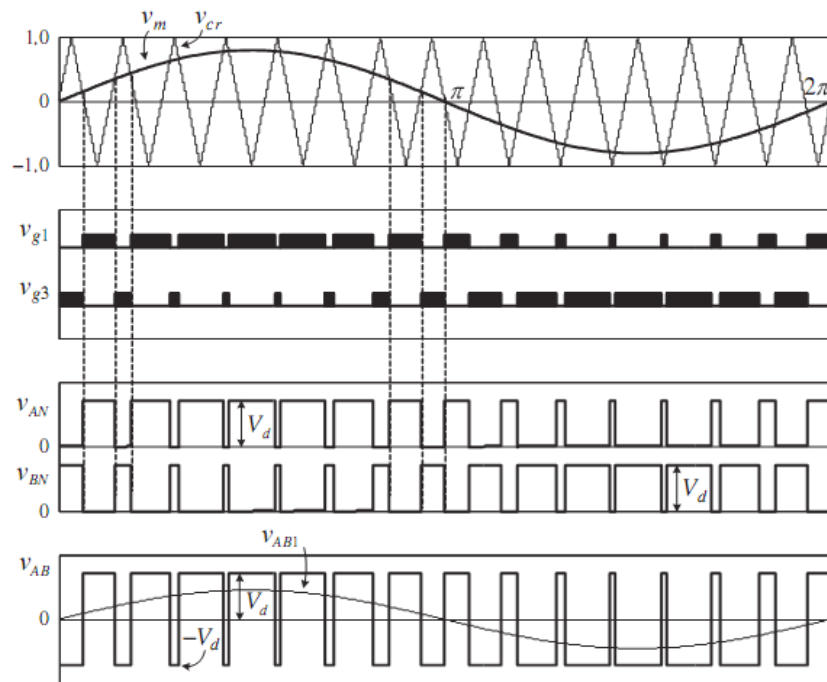

**Fig.5.9** Bipolar PWM, output waveforms at  $m_f=15$ ,  $m_a=0.8$ ,  $f_m=60$  Hz and  $f_{cr}=900$  Hz

$V_{g1}$  and  $V_{g3}$  are the gate signals used to control the opening and closing of the upper switches  $S1$  and  $S3$ , respectively. Therefore, ( $S1$  and  $S4$ ) are on when  $V_m > V_{cr}$  ( $V_{AB} = +V_d$ ), and ( $S2$  and  $S3$ ) are on when  $V_m < V_{cr}$  ( $V_{AB} = -V_d$ ).

The upper and lower switches in the same inverter leg operate in a complementary manner with one switch turned on and the other turned off. The inverter output voltage can be found from  $V_{AB} = V_{AN} - V_{BN}$ . Since the waveform of  $V_{AB}$  switches between the positive and negative dc voltages  $\pm V_d$ , this scheme is known as bipolar modulation.

**Unipolar PWM**

The unipolar modulation requires two sinusoidal modulating waves,  $V_m$  and  $V_{m-}$ , which are of the same magnitude and frequency but  $180^\circ$  out of phase as shown in Fig.5.10. The two modulating waves are compared with a common triangular carrier wave  $V_{cr}$ , generating two gating signals,  $V_{g1}$  and  $V_{g3}$ , for the upper switches,  $S1$  and  $S3$ , respectively.

( $S1, S4$ ) are on  $V_m > V_{cr}$

( $S2, S3$ ) are on  $V_{m-} > V_{cr}$

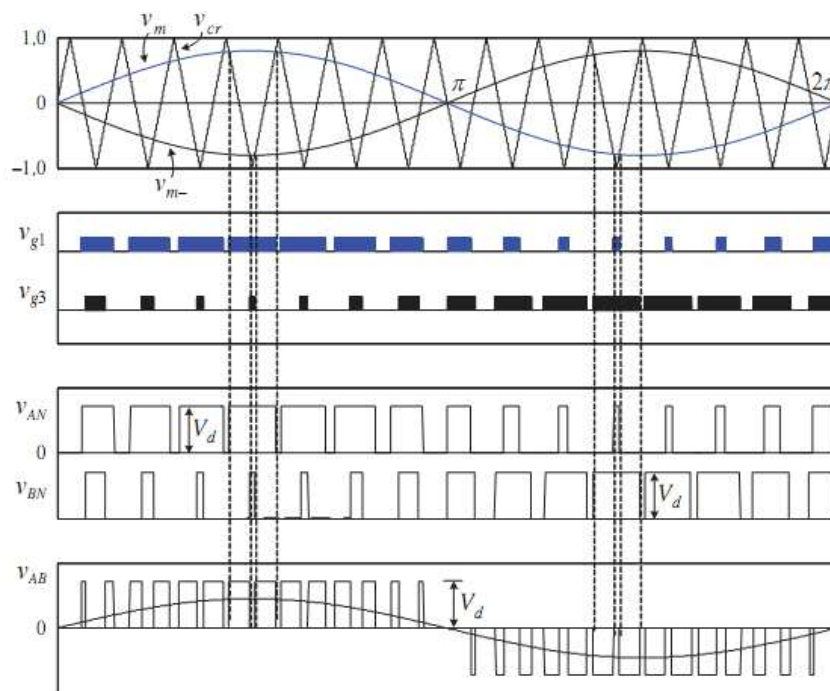
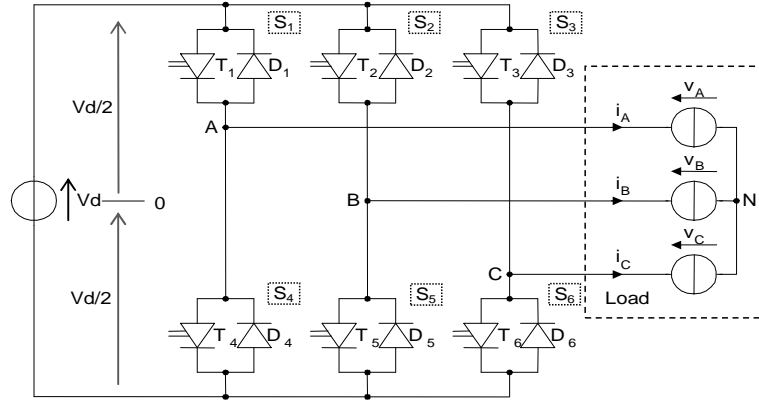

**Fig.5.10** Unipolar PWM, output waveforms at  $m_f=15$ ,  $m_a=0.8$ ,  $f_m=60$  Hz and  $f_{cr}=900$  Hz

It can be observed that the two upper switches do not commute simultaneously, which is distinguished from the bipolar PWM where all four devices are commutated at the same time. The inverter output voltage is switched either from  $+V_d$  to zero during the positive half cycle or from  $-V_d$  to zero during the negative half cycle of the fundamental frequency, rather than between high and low as in bipolar switching.

**3. Three-phase voltage inverters:**

The three-phase inverter is the assembly of three half-bridge inverters, thus forming a configuration with three legs. These three legs are controlled by three signals shifted by  $2\pi/3$  relative to each other.



**Fig.5.11** Three-phase VSI inverter circuit

**Output voltage calculation:**

If S1 is closed and S4 is open,  $v_{AO}=Vd/2$ . If S1 is open and S4 is closed,  $v_{AO}= -Vd/2$ .

$$u_{AB} = v_{A0} - v_{B0}$$

$$u_{BC} = v_{B0} - v_{C0}$$

$$u_{CA} = v_{C0} - v_{A0}$$

Then  $v_{AN}, v_{BN}, v_{CN}$  if a star connection is used:

$$v_{AN} = v_{A0} - \frac{1}{3}(v_{A0} + v_{B0} + v_{C0})$$

Knowing that: 
$$\begin{bmatrix} v_{A0} \\ v_{B0} \\ v_{C0} \end{bmatrix} = \begin{bmatrix} q_1 - q_4 \\ q_2 - q_5 \\ q_3 - q_6 \end{bmatrix} \frac{Vd}{2}$$

With:  $q_1, q_2, q_3, q_4, q_5,$  and  $q_6$  being the control signals for switches S1, S2, S3, S4, S5, and S6 respectively.

$$\begin{cases} u_{AB} = v_{AN} - v_{BN} = v_{A0} - v_{B0} & (1) \\ u_{BC} = v_{BN} - v_{CN} = v_{B0} - v_{C0} & (2) \\ u_{CA} = v_{CN} - v_{AN} = v_{C0} - v_{A0} & (3) \end{cases}$$

For a balanced three-phase load:

$$v_{AN} + v_{BN} + v_{CN} = 0 \quad (4)$$

This leads to : 
$$\begin{cases} v_{AN} = v_{A0} - v_{N0} = \frac{1}{3}(2v_{A0} - v_{B0} - v_{C0}) \\ v_{BN} = v_{B0} - v_{N0} = \frac{1}{3}(-v_{A0} + 2v_{B0} - v_{C0}) \\ v_{CN} = v_{C0} - v_{N0} = \frac{1}{3}(-v_{A0} - v_{B0} + 2v_{C0}) \end{cases}$$

The following table provides, for the eight configurations that the converter can take, the state (F for closed or O for open) of the three switches S1, S2, and S3.

S1	S2	S3	$U_{AB}$	$U_{BC}$	$U_{CA}$	$V_A$	$V_B$	$v_c$
F	F	F	0	0	0	0	0	0
F	O	F	$V_d$	$-V_d$	0	$V_d/3$	$-2V_d/3$	$V_d/3$
F	F	O	0	$V_d$	$-V_d$	$V_d/3$	$V_d/3$	$-2V_d/3$
F	O	O	$V_d$	0	$-V_d$	$2V_d/3$	$-V_d/3$	$-V_d/3$
O	F	F	$-V_d$	0	$V_d$	$-2V_d/3$	$V_d/3$	$V_d/3$
O	O	F	0	$-V_d$	$V_d$	$-V_d/3$	$-V_d/3$	$2V_d/3$
O	F	O	$-V_d$	$V_d$	0	$-V_d/3$	$2V_d/3$	$-V_d/3$
O	O	O	0	0	0	0	0	0

**a) Symmetrical control (full wave):**

In this case, each switch conducts for half of the period T. Switches S1 and S4, S2 and S5, S3 and S6 in each bridge arm must be in complementary states pairwise. For the other voltages, the waveforms are the same but shifted from each other by T/3.

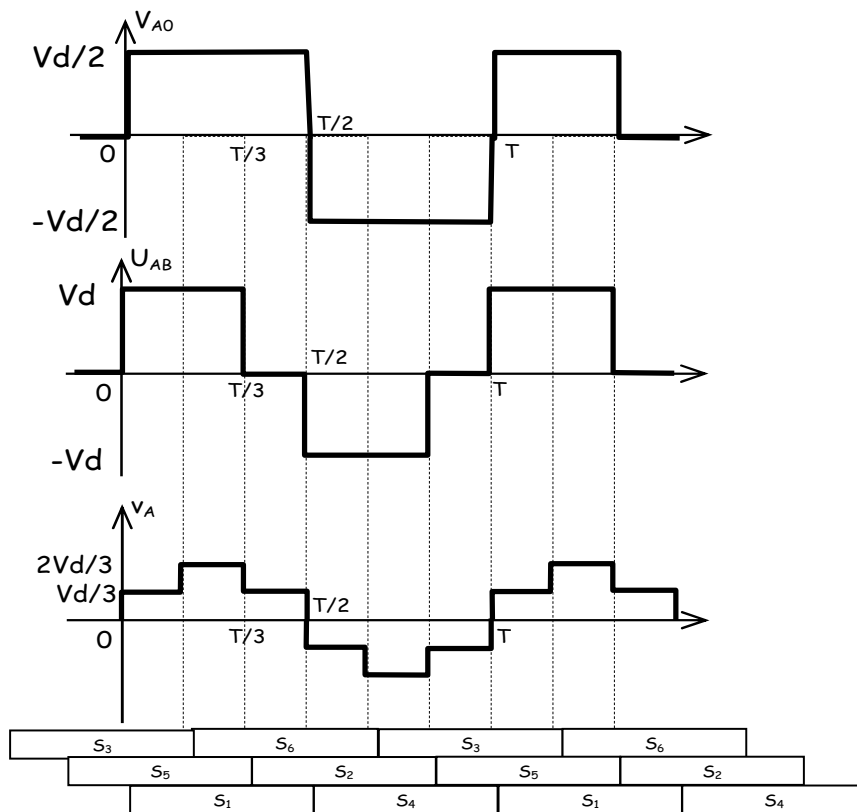

**Fig.5.12** Output voltage for symmetrical control (full wave)

**b) Pulse width modulation (PWM) control:**

The application of Pulse Width Modulation (PWM) for a three-phase inverter is identical to its application in single-phase, except instead of one (01) reference signal, three (03) sinusoidal reference signals are used, each shifted by  $2\pi/3$ .

The control signals ( $q_4, q_5,$  and  $q_6$ ) for S4, S5, and S6 are obtained by inverting the signals  $q_1, q_2,$  and  $q_3$ , respectively.

Figure 5.13 illustrates an example of obtaining the control signals for:  $m_f = 10, m_a = 0.8$ .

Given that:  $V_d = 20V, f_m = 50\text{ Hz}, f_{cr} = 500\text{ Hz}$ .

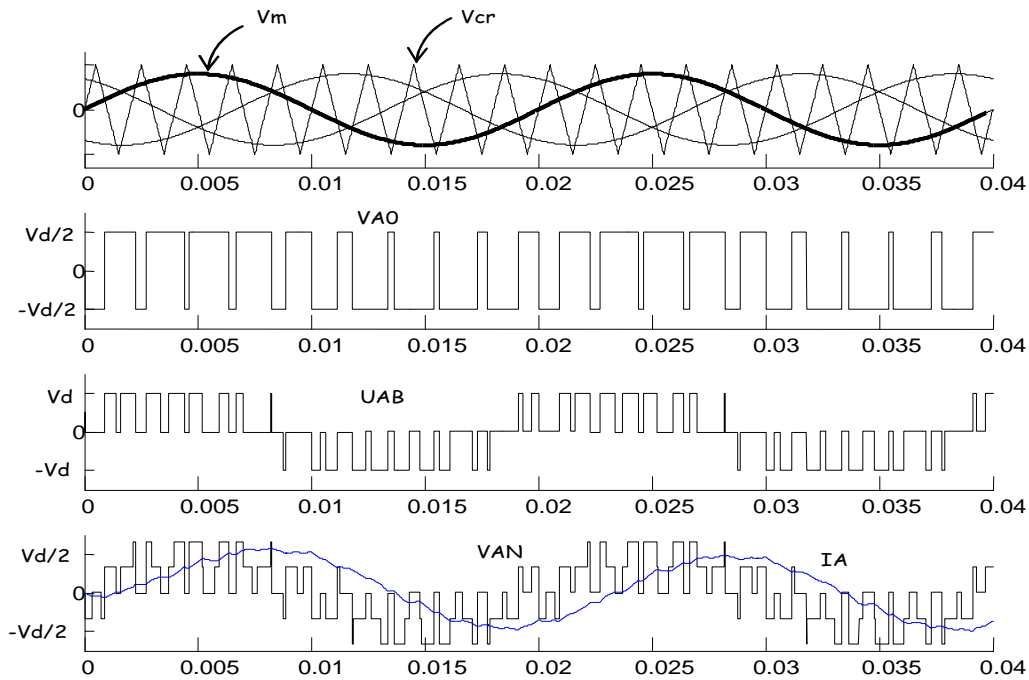
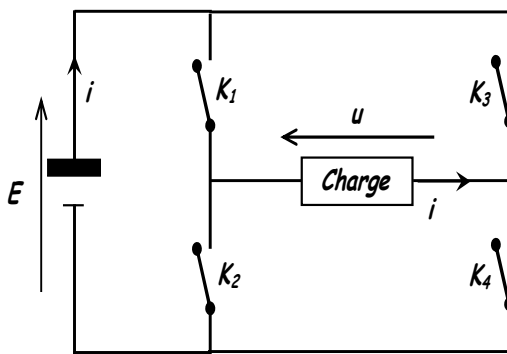

**Fig.5.13** Output voltage for PWM control

**4. Problems:**

**Problem 4.1:**

A single-phase inverter delivers the following voltage (Fig.2) to its load.



**Fig.1**

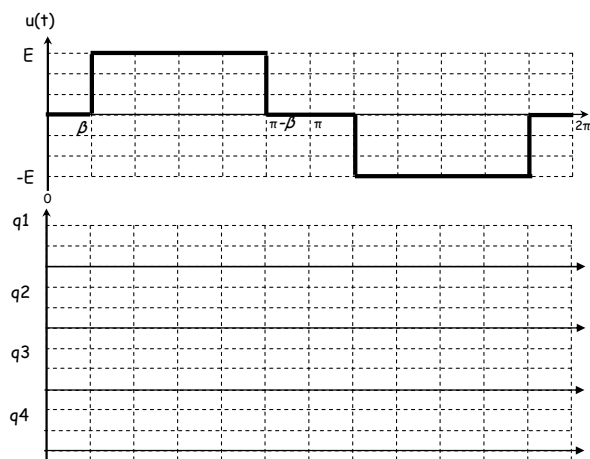

**Fig.2**



The switches  $K_1, K_2, K_3,$  and  $K_4$  are of the (transistor with diodes in anti-parallel) type controlled by the signals  $q_1, q_2, q_3,$  and  $q_4$ .

- 1- Plot on the document (Fig.2) the control signal for each switch corresponding to the voltage  $u(t)$  over the interval  $[0, 2\pi]$ .
- 2- Determine the expression for the rms value  $U$  in terms of  $E$  and  $\beta$ .
- 3- The load is a  $10 \Omega$  resistor,  $E=20V$ . For what value of  $\beta$  will the load receive a power of  $30 W$ ?
- 4- For an inductive load, the sinusoidal current lags the voltage by an angle of  $\pi/6$ .
  - Plot the voltage wave  $u(t)$  and the current wave  $i(t)$  on the same document.
  - Indicate the elements that are conducting during one period.

**Problem 4.2:**

The single-phase full-bridge inverter shown below is operated in the quasi-square-wave mode at the frequency  $f = 100 \text{ Hz}$  with a phase-shift of  $\beta$  between the half-bridge outputs  $v_{a0}$  and  $v_{b0}$ .

- (a) With a purely resistive load  $R = 10 \Omega$ , find  $\beta$  so that the average power supplied to the load is  $P_{o,av} = 2 \text{ kW}$ .
- (b) With a purely inductive load  $L = 20 \text{ mH}$  and  $\beta = 2\pi/3$ ,
  - i. Find the peak-to-peak value ( $I_{pp}$ ) of the load current  $i_o$ .
  - ii. Find the amplitude of the fundamental component ( $I_{o1}$ ) of  $i_o$ .

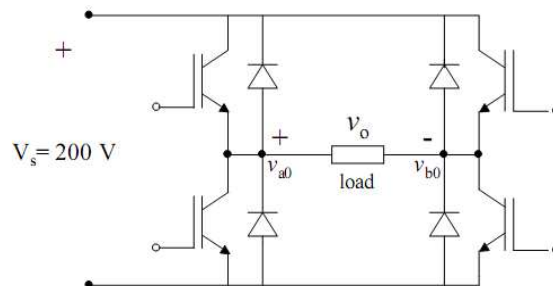

**Solution 4.1:**

- 1- The control signal for each switch corresponding to the voltage  $u(t)$ :

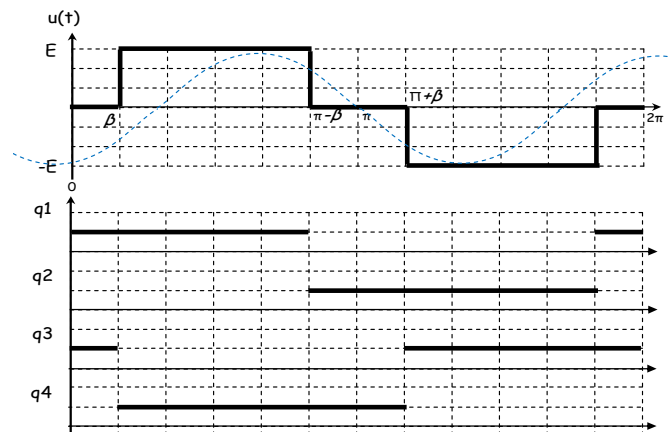

2- The expression for the rms value U in terms of E and β:

$$U^2 = \frac{1}{T} \int_0^T u_c^2 dt = \frac{1}{\pi} \int_{\beta}^{\pi-\beta} E^2 d\omega t = E^2 \left(1 - \frac{2\beta}{\pi}\right)$$

$$U = E \sqrt{1 - \frac{2\beta}{\pi}}$$

3- The value of β, the load receives a power of 30 W:

$$P = RI^2 = \frac{U^2}{R} \rightarrow \beta = \frac{\pi}{2} \left(1 - \frac{P \times R}{E^2}\right) = \frac{\pi}{2} \left(1 - \frac{30 \times 10}{20^2}\right) = \frac{\pi}{8}$$

4- For an inductive load, the sinusoidal current lags the voltage by an angle of π/6

**Solution 4.2:**

(a) With a purely resistive load:  $i_0 = \frac{v_0}{R}$ ,

Instantaneous power:  $p_0(t) = v_0(t) \times i_0(t) = \frac{v_0^2}{R}$

$$P_{0,av} = \frac{1}{T} \int_0^T p_0(t) dt = \frac{1}{R} \left(\frac{1}{T} \int_0^T v_0^2(t) dt\right) = \frac{V_{0,rms}^2}{R}, \quad V_{0,rms} = V_s \sqrt{\frac{\beta}{\pi}}$$

$$\frac{V_s^2 \beta}{R \pi} = 2000 \text{ W} \implies \beta = \frac{\pi}{2}$$

(b)

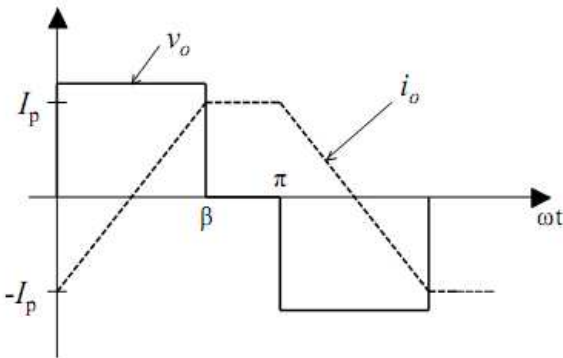

(i)  $0 \leq t \leq \frac{\beta}{\omega}: L \frac{di_o}{dt} = V_s \rightarrow i_o(t) = -I_p + \frac{V_s}{L} t$

at  $t = \frac{\beta}{\omega}: i_o = -I_p \rightarrow I_p = -I_p + \frac{V_s \beta}{L \omega}$

$$I_{pp} = 2I_p = \beta \frac{V_s}{\omega L} = \frac{2\pi}{3} \frac{200}{200\pi^2 \times 0.02} = 33.33A$$

(ii)  $I_{01} = \frac{V_{01}}{\omega L}, \quad V_{01} = \frac{4V_s}{\pi} \sin(\beta/2) \rightarrow I_{01} = \frac{800}{200\pi^2 \times 0.02} \sin(\pi/3) = 17.55A$

## Appendix

### Non-sinusoidal periodic signals

#### I) Fourier series expansion:

Any periodic function (signal) with a period (T) such that  $x(t) = x(t+T)$  can be decomposed into a sum comprising:

- a constant term (the DC component)
- a sinusoidal term with a frequency  $f=1/T$ , referred to as the fundamental (first harmonic).
- a finite or infinite series of sinusoidal terms with frequencies that are integer multiples of the fundamental frequency (f), known as harmonics.

$$x(t) = a_0 + \sum_{n=1}^{+\infty} [a_n \cos(n\omega t) + b_n \sin(n\omega t)]$$

$$= a_0 + \sum_{n=1}^{+\infty} [A_n \cos(n\omega t + \alpha_n)] = a_0 + \sum_{n=1}^{+\infty} [A_n \sin(n\omega t + \beta_n)], \beta_n = \alpha_n + \frac{\pi}{2}$$

$$a_0 = \frac{1}{T} \int_0^T x(t) dt; \quad a_n = \frac{2}{T} \int_0^T x(t) \cos(n\omega t) dt; \quad b_n = \frac{2}{T} \int_0^T x(t) \sin(n\omega t) dt$$

Sines and cosines of the same frequency can be combined into one sinusoid, resulting in an alternative expression for a Fourier series.

$$x(t) = a_0 + \sum_{n=1}^{+\infty} [A_n \cos(n\omega t + \theta_n)]$$

$$A_n = \sqrt{a_n^2 + b_n^2} \text{ and } \theta_n = \tan^{-1} \left( -b_n/a_n \right)$$

Or

$$x(t) = a_0 + \sum_{n=1}^{+\infty} [A_n \sin(n\omega t + \theta_n)]$$

$$A_n = \sqrt{a_n^2 + b_n^2} \text{ and } \theta_n = \tan^{-1} \left( a_n/b_n \right)$$

\* This signal is often represented in the form of a spectrum. To each harmonic frequency  $f_n$ , a corresponding value of  $A_n$  is assigned.

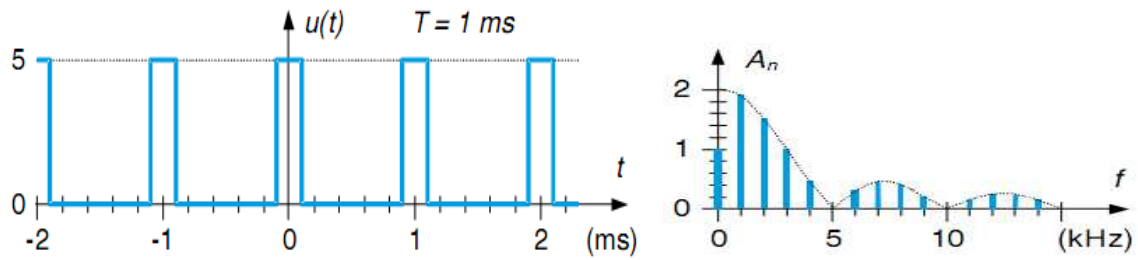

### I.1. Simplifications due to certain symmetries:

Often, the waveform of the analyzed quantity exhibits symmetries that allow simplification in calculating the terms of its Fourier series expansion.

**-Even periodic signal:**  $\forall t, x(t) = x(-t)$

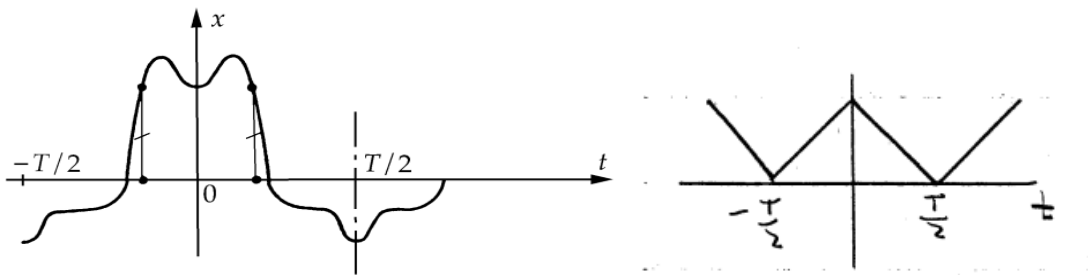

So:

All sine terms are zero,

Cosine terms can be calculated over half a period:

$$a_0 = \frac{2}{T} \int_0^{T/2} x(t) dt$$

$$a_n = \frac{4}{T} \int_0^{T/2} x(t) \cos(n\omega t) dt$$

**-Odd periodic signal:**  $\forall t, x(t) = -x(-t)$

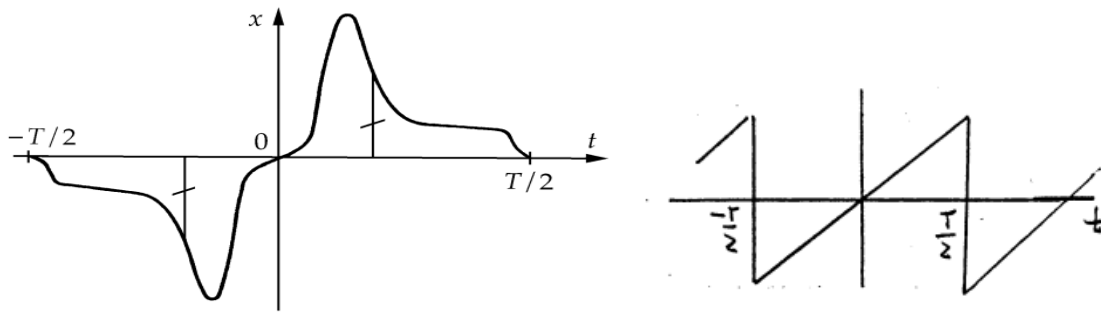

So:

All cosine terms disappear,

The calculation of sine terms is simplified:

$$a_0 = 0$$

$$b_n = \frac{4}{T} \int_0^{T/2} x(t) \sin(n\omega t) dt$$

**-Sliding symmetry:** The negative half-wave is identical, up to sign, to the positive half-wave. If it is slid underneath the positive half-wave, symmetry with respect to the time axis is obtained:

$$\forall t, x\left(t + \frac{T}{2}\right) = -x(t)$$

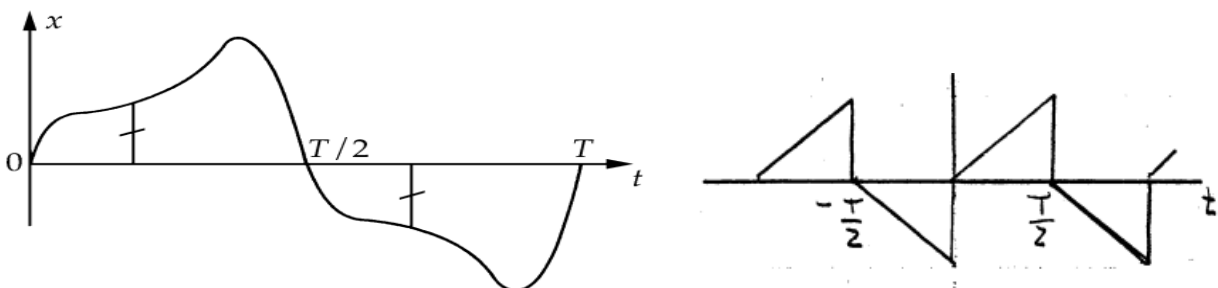

So:

The constant term  $a_0$  is zero,

The series expansion does not contain harmonics of even order,

The calculation of odd harmonics is simplified:

$$a_{2k+1} = \frac{4}{T} \int_0^{T/2} x(t) \cos((2k+1)\omega t) dt$$

$$b_{2k+1} = \frac{4}{T} \int_0^{T/2} x(t) \sin((2k+1)\omega t) dt$$

### I.2. Effective values (RMS):

$$x_{rms}^2 = a_0^2 + \frac{1}{2} \sum_{n=1}^{+\infty} (a_n^2 + b_n^2) = a_0^2 + \frac{1}{2} \sum_{n=1}^{+\infty} A_n^2 = A_0^2 + \frac{1}{2} \sum_{n=1}^{+\infty} A_{nrms}^2$$

Where:  $A_0 = |a_0|$ ,  $A_{nrms} = \frac{A_n}{\sqrt{2}}$

### I.3. Form and ripple factors:

Form factor	Ripple factor	relation
$F = \frac{x_{rms}}{\bar{x}} = \frac{\sqrt{A_0^2 + \sum_{n=1}^{+\infty} A_{nrms}^2}}{A_0}$	$\beta = \frac{x_{Altrms}}{\bar{x}} = \frac{\sqrt{\sum_{n=1}^{+\infty} A_{nrms}^2}}{A_0}$	$F^2 = 1 + \beta^2$

**I.4. Harmonic distortion rate:** it is used to quantify the deformation of a signal that should be sinusoidal.

$$THD = \frac{\sqrt{\sum_{n=2}^{+\infty} A_{nrms}^2}}{A_{1rms}} = \frac{\sqrt{A_{2rms}^2 + A_{3rms}^2 + \dots + A_{nrms}^2 \dots}}{A_{1rms}}$$

If the signal is sinusoidal (THD=0)

### I.5. Power:

$$u(t) = U_0 + \sum_{n=1}^{+\infty} U_n \sqrt{2} \cos(n\omega t + \alpha_n) ; U_0 = \overline{u(t)}, i_0 = \overline{i(t)}$$

$$i(t) = I_0 + \sum_{n=1}^{+\infty} I_n \sqrt{2} \cos(n\omega t + \beta_n) ; U_n = U_{nrms}, I_n = I_{nrms}$$

-Instantaneous power:  $p(t) = u(t) \times i(t)$

-Active power or average power:  $p = \overline{p(t)} = U_0 I_0 + \sum_{n=1}^{\infty} U_n I_n \cos \varphi_n = \sum_{n=1}^{\infty} p_n$ ;  $\varphi_n = \alpha_n - \beta_n$

-Apparent power:  $S = UI = \sqrt{(U_0^2 + \sum_{n=1}^{+\infty} U_n^2) \times (I_0^2 + \sum_{n=1}^{+\infty} I_n^2)}$

-Power factor:  $Fp = \frac{p}{S}$

**\*Special case:** for a sinusoidal voltage  $u(t)$  and a periodic alternating current  $i(t)$  ( $I_0=0$ ).

$u(t) = U \sqrt{2} \cos(\omega t + \alpha)$ ;  $U = U_{rms}$

$i(t) = \sum_{n=1}^{+\infty} I_n \sqrt{2} \cos(n\omega t + \beta_n)$ ;  $I_n = I_{nrms}$

- Active power:  $p = UI_1 \cos \varphi_1$ ;  $\varphi_1 = \alpha - \beta_1$

- Reactive power:  $Q = UI_1 \sin \varphi_1$

- Apparent power:  $S = UI = U \sqrt{(\sum_{n=1}^{+\infty} I_n^2)}$

- Distortion power:  $D = \sqrt{S^2 - p^2 - Q^2} = U \sqrt{(\sum_{n=2}^{+\infty} I_n^2)}$

- Power factor:  $Fp = \frac{p}{S} = \frac{I_1 \cos \varphi_1}{I} = Fdis \times Fdep$

Fdis : Distortion factor (Fdis= $I_1/I$ )

Fdep : Displacement factor (Fdep= $\cos \varphi_1$ )

The power factor of a load drawing a non-sinusoidal current can thus be expressed in terms of the harmonic distortion rate of the current:  $Fp = \frac{\cos \varphi_1}{\sqrt{1+THD^2}}$

Therefore, it turns out that the more "polluted" the current is, the more the power factor will be degraded.

## References

- [1] John G. Kassakian, Martin F. Schlecht and George C. Verghese, "Principles of Power Electronics", Addison-Wesley, 1991.
- [2] Muhammad Rashid, " Power Electronics: Circuits, Devices & Applications 4th Edition", Pearson; 4th edition (July 19, 2013).
- [3] Daniel W. Hart, "Power Electronics", McGraw-Hill Companies Inc., New York, 2010.
- [4] Robert W. Erickson, Dragan Maksimovic, "Fundamentals of Power Electronics", Springer; 2nd edition (January 31, 2001).
- [5] Guy Séguier, Francis Labrique, Philippe Delarue, "Electronique de puissance, structures, commandes, applications", Cours et exercices corrigés, 10<sup>e</sup> édition, Dunod, Paris, 2015.