

Ministry of Higher Education and Scientific Research

University of M'HAMED BOUGARA BOUMERDES

Faculty of Engineering



In Partial fulfillment

Of the Requirements for the Master Degree

In Mechanics and Systems Engineering

TOPIC

**Study of active vehicle suspension systems
with fuzzy logic controller**

Realized by:

Ms. MOUFFOK Bessma

Supervised by:

Mr. SETTET Ahmed Tidjani

2016/2017

Acknowledgments

I thank **god** for giving us life , health , courage and the will to undertake this journey and appreciate the fruit the effort

This work was done in the dynamic laboratory of the engine and vibracoustics (laboratoire des moteurs et vibracoustique LDMV)

First , I was to thank **Mr. SETTET Ahmed Tidjani** , a teacher at university of Mohamed Bougara Boumerdes, who made this experience enjoyable as well as challenging without him this work would never have been possible

I also want to thank **juries** members for their interest to my work

I thank go to my teacher **Mr. NOUR . AbdelelKader**, a professor at at university of Mohamed Bougara Boumerdes, We also thank our **teachers** for Mechanicals and engineering of the systems lastly

Finally I extend my sincere thanks to my family and all my friends for their support over many years of study



Dedication

*I dedicate this work to my dear parents, and all my family with their
never-ending support, assistance and
encouragement*

*I also dedicate my friends, my colleagues of Mechanical and
engineering of systems who gave me support when
I needed*



Abstract

The objective of this work to study the active and the passive suspension for compared it with the sky-hook model reference , with different road profile .The performance of the controller is compared with fuzzy logic controller and the active suspension system by performing computer simulations through the MATLAB and SIMULINK

KEYWORDS: the active, the passive, the sky-hook, fuzzy logic controller, road profile.

Résumé

L'objectif de ce travail est d'étudier la suspension active et passive pour la comparer avec la référence du modèle de crochet du ciel, avec un profil de route différent. La performance du contrôleur est comparée au contrôleur de logique floue et au système de suspension actif en effectuant des simulations par ordinateur à travers le MATLAB et SIMULINK

MOTS-CLÉS : le actif, le passif, le ciel-crochet, contrôleur de logique floue, profil de route.

ملخص

الهدف من هذا العمل هو دراسة التعليق النشط والسالب لمقارنته بمرجع نموذج هوك السماوي مع صورة مختلفة للطريق، لمقارنة أداء وحدة التحكم مع جهاز تحكم منطقي غامض ونظام التعليق النشط عن طريق إجراء المحاكاة الحاسوبية من خلال ماتلاب و سيمولينك.

الكلمة الرئيسية : النشطة، السلبية، سكاى هوك، تحكم منطوق غامض، لمحة الطريق.

Summary

General introduction.....	1
---------------------------	---

Chapter I: The suspension

I.1. Introduction	4
I.2. The role of suspension	5
I.3. Type of suspension	5
I.3.1. Active suspension	6
I.3.2. Semi-active suspension.....	6
I.3.3. Passive suspension.....	6
I.4. Discription of quarter model of vehicle.....	7
I.5. Passive suspension of a degree of freedom	7
I.5.1. Passive suspension model	8
I.5.2. Dynamic equation	8
I.6. Strategies of control sky-hook.....	9
I.6.1. Model of suspension sky-hook	9
I.6.2. Dynamic equation	10
I.7. Active suspension of a degree of freedom	11
I.7.1. Model of ctive suspension	11
I.7.2. Dynamic equation	12
I.8. Degree of freedom of vehicle	13
I.9. Vehicle suspension model	13
I.9.1. The quarter vehicle model	13
I.9.2. The half vehicle model	14
I.9.3. The full vehicle model	15

I.10. Linear active suspension system	16
I.11. The method of the optimal control LQR linear	16
I.12. Function of inputs	18
I.12.1. Excitation sinusoidal	18
I.12.2. Excitation impulse	18
I.12.3. Excitation echelon	19
I.13. Conclusion.....	19

Chapter II: Fuzzy control of an active suspension to a degree of freedom

II.1. Introduction.....	20
II.2. Linguistic variable	20
II.3. Membership function	21
II.4. Universe of discourse.....	22
II.5. Linguistic rules.....	22
II.6. The regulator of mamdani type.....	23
II.6.1. The structure of regulator of type mamdani.....	23
II.6.2. structure of fuzzy logic controller	23
II.6.3. Internal structure of fuzzy logic controller.....	24
II.6.4 The role of fuzzy logic controller.....	25
II.7. Procedure of fuzzy reasoning.....	26
II.7.1. Bloc of fuzzification.....	26
II.7.2. Bloc of inference.....	26
II.7.3. Bloc of defuzzification.....	27
II.8 Advantage and disadvantage	28
II.9. The controller by fuzzy logic	29
II.9.1. Fuzzification of the variable	29
II.9.1.1. The deflection	30

II.9.1.2. The velocity	31
II.9.1.3. The control force	32
II.9.2. Base of the rules	34
II.10. Conclusion	35

**Chapter III: Simulation of an active suspension
to a degree of freedom**

III.1. Introduction.....	36
III.2. The parameters of suspension	37
III.2.1. The parameters of suspension and sky-Hook reference	37
III.2.2. The profits used.....	37
III.3. The flow chart of simulation	38
III.4. Response of the system sinusoidal road input.....	39
III.4.1. Profile of sinusoidal road input	39
III.4.2. Simulation of sky-Hook model	40
III.4.3. Simulation of passive suspension	41
III.4.4. Simulation of active suspension	42
III.4.5. Compared of the passive suspension with the model of reference.....	43
III.4.5.1. Acceleration of the body of vehicle	43
III.4.5.2. Deflection of wheel.....	44
III.4.6. Compared of the active suspension with the model of reference.....	45
III.4.6.1. Acceleration of the body of vehicle	45
III.4.6.2. Deflection of wheel.....	46
III.4.6.3. Control force.....	47
III.5. Response of the system to an echelon road profile input	48
III.5.1. Profile of the echelon input.....	48
III.5.2. Simulation of the active suspension.....	49

III.5.3. Simulation of the passive suspension.....	50
III.5.4. Simulation of the sky-hook model	51
III.5.5. Compared the passive suspension with model of reference.....	52
III.5.5.1.Acceleration of the body of vehicle	52
III.5.5.2.Deflection of wheel	53
III.5.5.3. Control force.....	54
III.6. Conclusion	55

General conclusion

Bibliography

LIST OF FIGURES

Chapter I: The suspension

Figure. I.1: The quarter vehicle model	7
Figure. I.2: Model of passive suspension	8
Figure.I.3: Model of sky-hook suspension	10
Figure.I.4: Model of active suspension	12
Figure. I.5: Degree of freedom of vehicle.....	13
Figure. I.6: The quarter vehicle model to two degree of freedom.....	14
Figure.I.7: The half vehicle model to four degree of freedom	14
Figure.I.8: The full vehicle model to two degree of freedom	15
Figure.I.9: Active suspension of control of system	16
Figure I.10. : Block diagram of LQR control schematic	18

Chapter II: Fuzzy control of an active suspension to a degree of freedom

Figure.II.1: various form of membership function.....	22
Figure.II.2: Schematic diagram of the adjustment by fuzzy logic.....	23
Figure.II.3: Diagram of fuzzy logic controller	24
Figure.II.4.: Internal structure of th regulator by fuzzy logic controller	24
Figure.II.5: Deffuzification by the method of the center of gravity	28
Figure.II.6.a: The membership function of the input variable of the deflection.....	30
Figure.II.6.b: The membership function of the input variable of the velocity	31
Figure.II.6.c: The membership function of the output variable of the control force	32

**Chapter III : Simulation of an active suspension
to a degree of freedom**

Figure.III.1: Resolution of the differential equation	38
Figure.III.2.: Sinusoid road profile input	38
Figure.III.3.a: Functional schematic of sky-hook model for simulink.....	40
Figure.III.3.b: Functional diagram sky-hook model	40
Figure.III.4.a: Functional Schema of passive suspension for simulink	41
Figure.III.4.b: Functional diagram passive model	41
Figure.III.5.a: functional Schematic of active suspension simulink	42
Figure.III.5.b: Functional diagram of active model	42
Figure.III.6.a: Acceleration of sky-hook model and passive suspension	43
Figure.III.6.b: Deflection of sky-hook model and passive suspension	44
Figure.III.7.a: Acceleration of sky-hook and active suspension	45
Figure.III.7.b: Deflection of sky-hook and active suspension	46
Figure.III.7.c: Control force of active suspension	47
Figure.III.8.a: Acceleration of active , passive suspension and sky-hook model	48
Figure.III.8.b: Echelon road profile input	48
Figure.III.9.a: Functional schematic of active model for simulink.....	50
Figure.III.9.b: Functional diagram active model	50
Figure.III.10.a: Functional Schema of passive suspension for simulink	51
Figure.III.10.b: Functional diagram passive model	51
Figure.III.11.a: functional Schematic of sky-hook suspension simulink	52
Figure.III.11.b: Functional diagram of sky-hook model	52

Figure.III.12.a: Acceleration of suspension with model of reference	53
Figure.III.12.b: Deflection of suspension with mode of reference.....	53
Figure.III.12.a: Control force active suspension	54

List of tables

Table II.1.a: Parameters of the membership function of the deflection	30
Table II.1.b: Parameters of the membership function of the velocity	31
Table II.1.c: Parameters of the membership function of the control force	32
Table II.2. Base rules for the controller by fuzzy logic	34
Table. III.1. The parameters of active passive suspension and sky-hook reference	37

General introduction

A car suspension system is the mechanism that physically separates the car body from the wheels of the car. The purpose of suspension system is to improve the ride comfort, road handling and stability of vehicles. Apple yard and Well stead have proposed several performance characteristics to be considered in order to achieve a good suspension system. Suspension consists of the system of springs, shock absorbers and linkages that connects a vehicle to its wheels. In other meaning, suspension system is a mechanism that physically separates the car body from the car wheel. The main function of vehicle suspension system is to minimize the vertical acceleration transmitted to the passenger which directly provides road comfort [25].

An active suspension system has the ability to store, dissipate and to introduce energy to the system. It may vary its parameters depending upon operating conditions. Generally, traditional suspension consists springs and dampers are referred to as passive suspension, then if the suspension is externally controlled it is known as a semi active or active suspension [25]. In other way, active suspension can gave better performance of suspension by having force actuator, which is a closed loop control system, fuzzy logic have been used in the area of active suspensions systems .

In this study, a mathematical model for the passive and active suspensions systems for quarter car model that subject to excitation from a road profile using fuzzy logic controller is conducted. Will be compared the active and the passive suspension of a degree freedom of the quarter vehicle compared to the sky-hook reference model with different road profile. The performance of the controller is compared with fuzzy logic controller and the active suspension system by performing computer simulations through the MATLAB and SIMULINK toolbox.

Chapter I:

The suspension

I.1 Introduction

Each moving traffic is exposed to vibrations due to the deformations which the profile of the road presents. These vibrations to which the bodies of the vehicle are subjected, are transmitted mainly to the passengers, from where the need to decrease them to reduce the harmful effects of them and to make them tolerable. Thus, the man very quickly became aware of the need for returning the profile of the uniform roadway.

In spite of the evolution of the research results to improve flatness of the coating of the roads, the lack of comfort persists. It is all the more true as the users are sometimes compelled to roll on ways hardly suitable for motor vehicles, to even make except track, where as the vehicles do nothing but more and more quickly run. Thus the research efforts were as directed towards the improvement of the suspension of the vehicles, in order to improve as well comfort of it as the security. The search more and more of comfort and security gave a new dimension and a more important weight to this concern .

With its beginnings, the passive suspension (without contribution of external energy), consisted of bodies deformable and elastic (roll or leaf springs, blocks of rubber, mattress of fluids, etc) nowadays, it understands also shock absorbers. The active suspension was born with the external contribution of energy.

In fact, the study of a suspension is complex because it brings into play [1]

- Suspended bodies (driving, gear box, radiator, etc)
- Not suspended bodies (travelling train, consisted the axles, wheels and the bridge)
- Bodies of connection between the two first and of which the suspension is part

In our approach of optimization of the parameters of the system of regulation of an active suspension by the genetic algorithms, we will treat following factors:

1. Handling of the vehicle: to ensure an adherence of the wheel on the profile of the road, some is the deformations (for better traction and braking)
2. The stability of the vehicle: to try to stabilize the vehicle some is the operations (turn, braking ...), and to decrease pitching and rolling

3. Vibratory insulation (comfort): to initially isolate the vibrations transmitted to the bodies from the vehicle and the passengers in the second place
4. The allowed race: to ensure a protection of the elements or bodies of the vehicle by fixing the dynamic deflection of the suspension

For that it is necessary:

- To ensure a force of contact constant wheel-road
- To decrease vertical and longitudinal accelerations of the frame, while basing itself on well defined standards

I. 2 The role of suspension

The suspension of the cars is the system which initially supports the weight statics of the vehicle. Moreover, this system must reduce or eliminate the vibrations generated by forces of the wind, forces of braking and irregularities of the roadway.

To control the vibration, the analysis of the following parameters is very important:

1. The acceleration of the body of the vehicle
2. The deflection of the suspension
3. The deflection of the wheels

At the time of the systems design of suspension, the objective of this last is to minimize the acceleration of the body of the vehicle, the deflection of the suspension and the deflection of the wheel. It is shown that with a weak acceleration of the body of the vehicle, one has more comfort and that minimal deflections of the suspension and wheel increase the contact between the wheel and the roadway what is translated by more security and of stability.

I.3 Types of suspension System

In general, there are three types of the suspension system [13]

1. Passive suspension
2. Semi-active suspension
3. Active suspension

I.3.1 Passive Suspension

The conventional suspension system is passive suspension system. It has two elements one of them is damper and another is spring. In this passive suspension, the purpose of the dampers is to dissipate the energy and the spring is to store the energy.

The springs are frequently used to store kinetic energy from moving components during deceleration and release this energy during acceleration to reduce peak loads. If a load exerted to the spring, it will compress until the force produced by the compression is equal to the load force.

For this type of suspension system damping coefficient and spring stiffness are fixed characteristics therefore this is the main weakness as parameters for ride comfort and good handling vary with different road surfaces, vehicle speed and disturbances.

I.3.2 Semi-active Suspension

The component in the semi-active suspension system is similar with passive suspension system and where external energy is needed in the system, it uses the same function of the active suspension system. The differentiation with passive suspension system is that the damping coefficient can be controlled. The fully active suspension is modified thus the actuator is only capable of dissipating power rather than supplying it as well. The actuator then becomes a continuously variable damper which is theoretically capable of tracking force demand signal independently of instantaneous velocity across it.

I.3.3 Active suspension

The active suspension system consists an additional element in the conventional suspension, which the main component of it is an actuator that is controlled by a high frequency response servo valve and which involves a force feedback loop.

In general, the duty of sensor in active suspension systems is to measure suspension variables such as body velocity, suspension displacement, and wheel velocity and wheel or body acceleration. In an active suspension system, actuators that supply additional forces improve the passive elements. A feedback control law via data from sensors attached to the vehicle determines these additional forces.

1.4 Description of the model of quarter of vehicle

The traditional suspensions which equipped the vehicles used springs assembled in parallel with passive shock absorbers the figure 1.1 watch a system of suspension with degrees of freedom. It represents one of the four corners of the vehicle, and is named commonly model of a quarter of vehicle [12].

This system is composed of the suspended mass (m), the not suspended mass (wheel), its damping coefficient (b) of the passive shock absorber, the coefficient of stiffness of the spring linear (k).

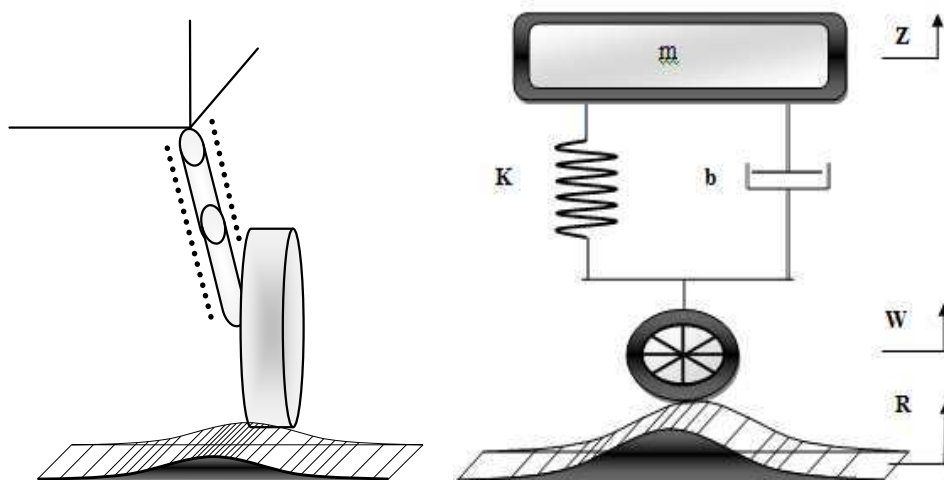

The figure I.1 The quarter vehicle model

1.5 Passive suspension to a degree of freedom

The passive suspension is of almost linear nature, it is based on the principle of dissipation of the energy stored by the spring and the shock absorber, the generated force, modeled by the model of Kelvin is a linear function of displacement and speed relative of the suspension. Although this model is used by the majority of the industrialists, it has limitations when it is a question of improving the comfort and the stability of the road vehicles, these limitations have pushed the researchers to find other models of suspensions [14].

I.5.1 Model of a passive suspension

It is a suspension carried out using passive elements such as springs, shock absorbers, whose manufacturing is simple and raised the enough performances, but which remains very limited compared to the ambitions of the manufacturers and the needs for the user (comfort, security).

The model of a passive suspension of a quarter of a vehicle to a degree of freedom (the figure.I.2) [2-3-4].

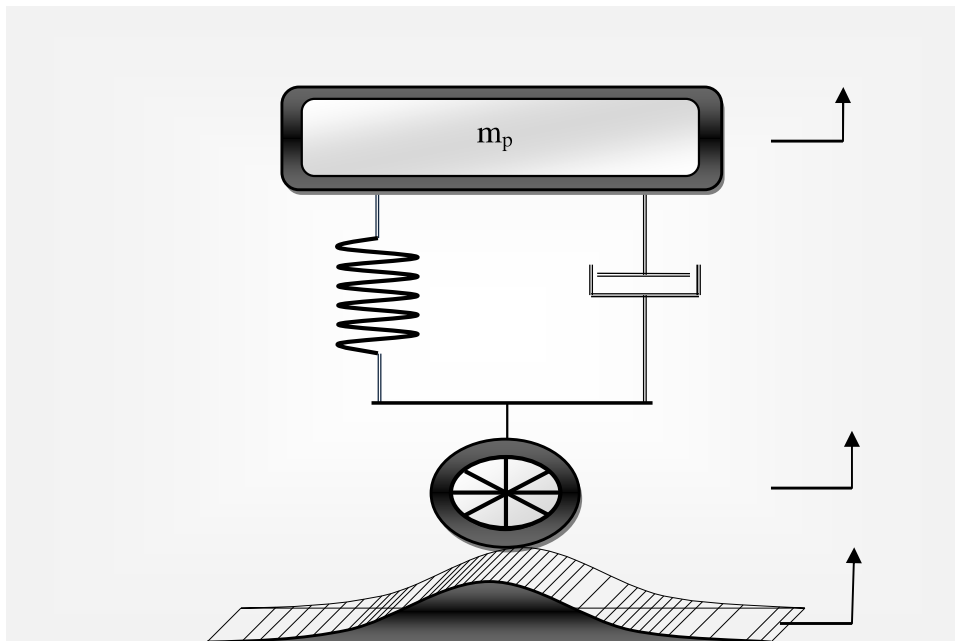

Figure I.2 Model of passive suspension

Where:

m_p [kg] = mass of the frame of a quarter of vehicle

b_p [N/m] = coefficient of stiffness of the spring

K_p [N/m/ s] = damping coefficient

I.5.2 Dynamic equation

The vibratory behavior is governed by the differential equation

$$m_p \ddot{z}_p = -k_p(z_p - w) - b_p(\dot{z}_p - \dot{w}) \quad (I.1)$$

$z_p(m)$ = vertical displacement of the mass.

$x_p = z_p - w$ = relative displacement enters the mass and the wheel.

$k_p(z_p - w)$ = force developed by the spring.

$b_p(\dot{z}_p - \dot{w})$ = force developed by the shock absorber.

I.6 Strategies of control

I.6 Control skyhook

One of the most popular controllers and most used for the active suspension in application commercial is the concept of control skyhook. In the strategies of control skyhook a shock absorber is placed between the suspended mass and a point imaginaries in the sky.

It is equivalent to the application of a force proportional and opposite within the meaning of speed of the mass suspended \dot{z}_m with an amplification so that it has no force applied to the not suspended mass.

Such an arrangement proves very effective by ordering the acceleration of the suspended mass \ddot{z}_m and is attractive because of the inherent simplicity from a practical point of view.

Unfortunately, this approach sky-hook is not practically plan table because it is not possible find it a fictitious point to fix the shock absorber at the sky-hook.

In practice, we call on the use of an actuator between masses suspended and not suspended even the figure I.3.

However, this leads to the deterioration of the dynamic performance of the not suspended mass since the entry of the control force is applied as well to the suspended mass as not suspended. Thus, the dynamic response of the system of suspended practical sky-hook is considerably worse than that of the system of suspension based by sky-hook ideal.

I.6.2 Model of a suspension (Sky-Hook)

The model of the Sky-Hook suspension represented by the figure I.3 is regarded as a reference for the systems design of systems of suspensions [2-3-4].

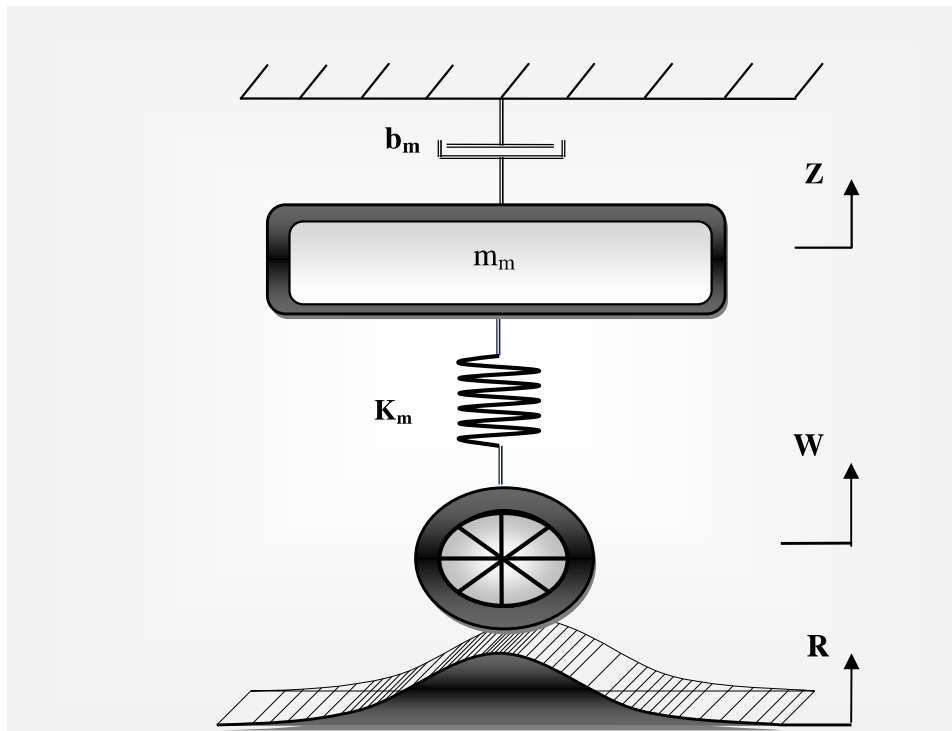

Figure. I.3 Model of a sky-hook suspension

Where

m_m [kg] = suspension mass of quarter car.

k_m [N/m] = the coefficient of stiffness of the spring.

b_m [N/m/ s] = the coefficient of the depreciation of the sky-hook model .

I.6.3 Dynamic equation

The vibration behavior is governed by the differential equation

$$m_m \ddot{z}_m = -k_m(z_m - w) - b_m \dot{z}_m \quad (\text{I.2})$$

It notes that the applied force F is of the form

$$F = -k_m(z_m - w) - b_m \dot{z}_m \quad (\text{I.3})$$

We designate by the deflection the relative displacement between the earth and the wheel and one writes

$$x_m = z_m - w \quad (\text{I.4})$$

I.7 The active suspension to a degree of freedom

One of the problems encountered in these types of suspension is the formulation of the force produced.

Certain researchers worked on the determination of a mathematical model which represent the force generated by these systems. We know that the active suspension generates one force which controls the mechanical system continuously.

The purpose of the use of this kind of suspension is to reduce the transmission risks of vibrations and to increase the factor of stability [14].

I.7.1 Model of the active suspension

In order to improve the performance of passive suspensions, one introduced a generator of effort (active element) placed in parallel with the spring and shock absorber as shown in the figure I. 4 [2-3-4-5].

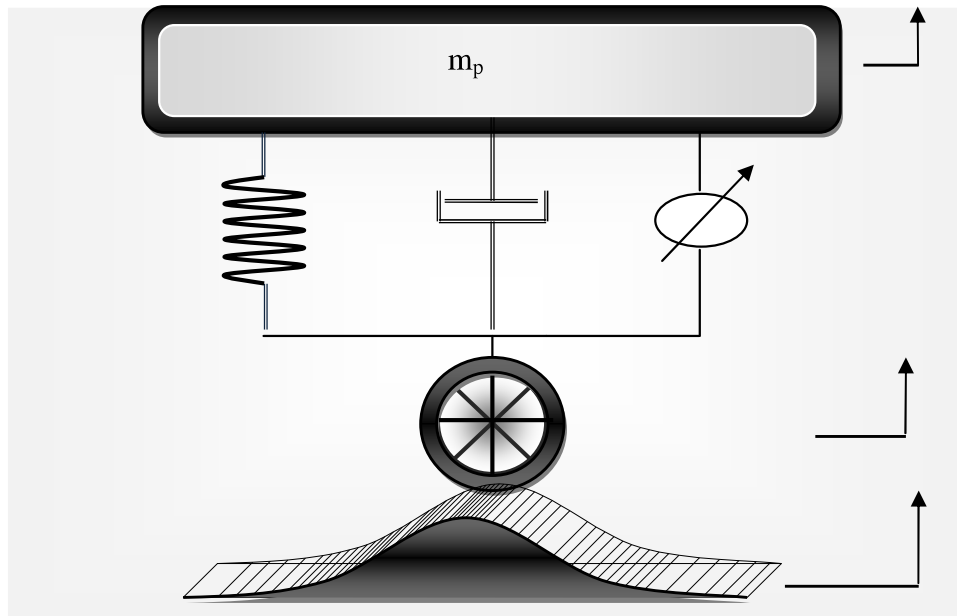

Figure I.4 Model of the active suspension

The model is characterized by

m_p [kg] = suspension mass of a quarter.

k_p [N/m] = coefficient of stiffness of the spring.

b_p [N/m/s] = coefficient of depreciation of a spring liabilities.

u [N] = force applied to the suspension governed by the actuator dynamic.

I.7.2 Dynamic equation

The dynamic equation which describes the movement of the system is

$$m_p \ddot{z}_p = -k_p (z_p - w) - b_p (\dot{z}_p - \dot{w}) + u \quad (\text{I.5})$$

With

z_p = vertical movement of the earth.

$x_p = z_p - w$ = deflection and relative displacement between the earth and the wheel.

I.8 Degrees of freedom of a vehicle

A vehicle can be driven according to the six degrees of freedom, three translations and three rotation [12]

1. The advance of the vehicle : according to X.
2. The shifting of the vehicle : according to Y.
3. The pumping of the vehicle: according to Z.
4. The rolling of the vehicle: (θ). Around X.
5. The pitching of the vehicle: (φ). Around Y.
6. The bouncing of the vehicle: (ψ). Around Z.

In our study one considers only the pumping of the vehicle

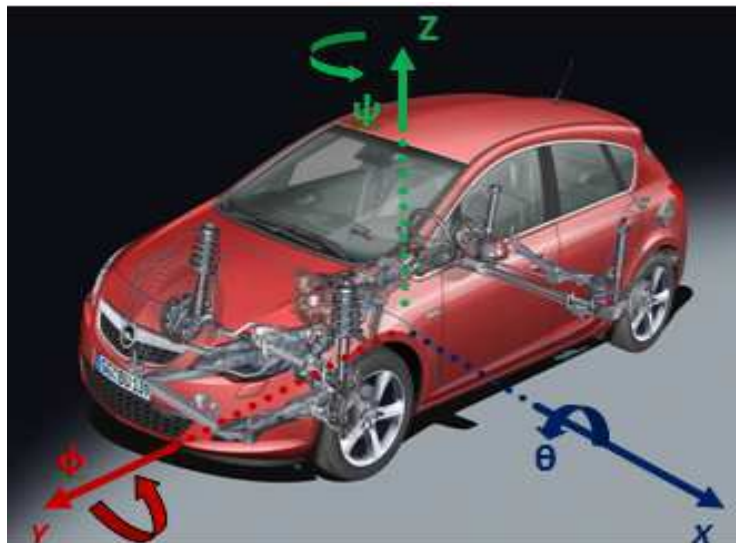

Figure I.5 Degrees of freedom of a vehicle

I.9 Vehicle Suspension Models

I.9.1 The quarter vehicle model

The quarter-car model suspension will represent the sprung mass, while wheel and axles are illustrated by the unsprung mass . The spring, shock absorber and a variable force-generating element placed between the sprung and unsprung mass constitutes suspension, the system as shown in Figure I.6.

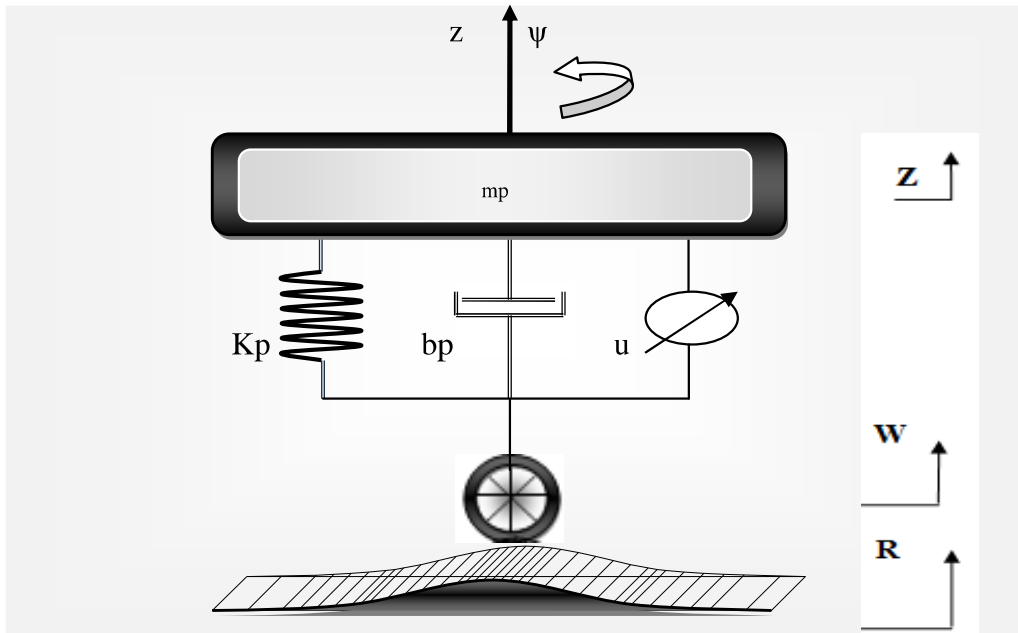

Figure I.6 The quarter vehicle model to tow degrees of freedom

I.9.2 The half vehicle model

Multi-body dynamics has been used extensively by automotive industry to model and design vehicle suspension. A simplified half model with four degrees of freedom are the pumping of not suspended masses (wheels) and of the suspended mass (mp) and rolling of the vehicle , the system as shown in Figure I.7.

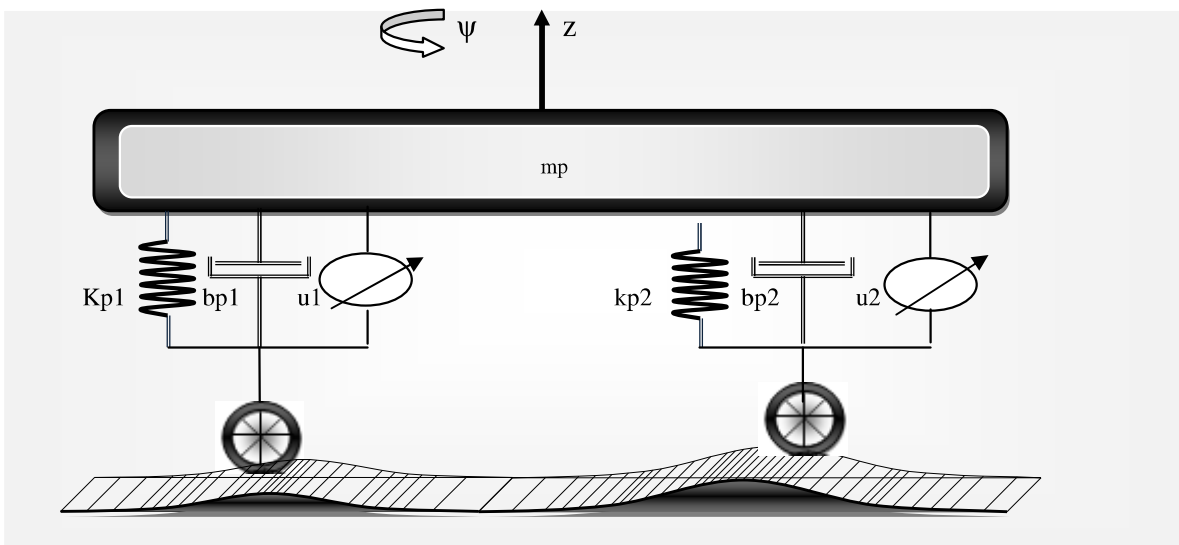

Figure I.7 The half vehicle model to four degrees of freedom

I.9.3 The full vehicle model

The physical model of the investigated system was formed by a full vehicle model and a human model by considering the human body as a dynamic system as well.

The human model was incorporated into a non-linear full vehicle model the body and wheel masses of the vehicle were assumed to be rigid bodies.

Compared to the other systems defined previously, the complete model of vehicle takes into account all the movement possible, the three displacement (advance, shifting and pumping) and of the three rotation (rolling, pitching and bouncing) for each element.

The full vehicle model to seven degrees of freedom is shown in Figure I.8. The model considered for simulation consists of seven degrees of freedom (DOF), which include longitudinal and lateral motions and yaw motion of the vehicle as well as the rotational dynamics of the four wheels.

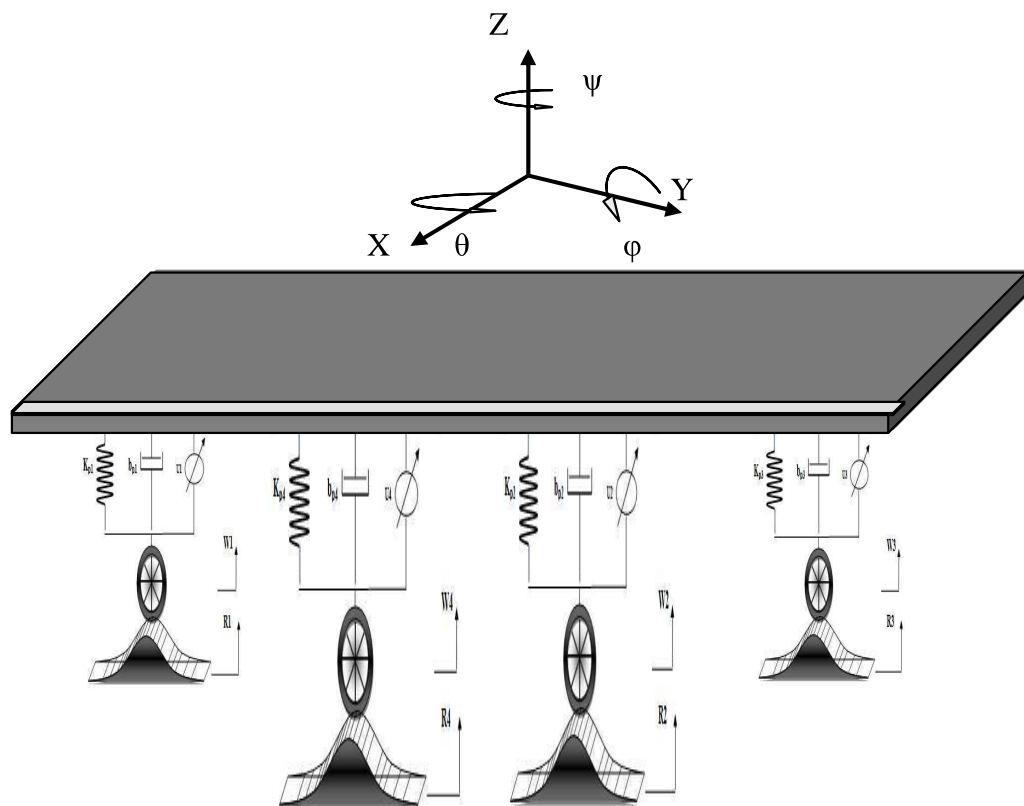

Figure I.8 The full vehicle model to seven degrees of freedom

I.10 Linear active suspension system

Active suspension system has the ability to response to the vertical changes in the road input. The damper or spring is interceding by the force actuator., This force actuator has it own task which is to add or dissipate energy from the system. Therefore active suspension system offer better riding comfort and vehicle handling to the passengers[10].

The force u developed by the actuator is determined from a control strategy aimed to optimize the dynamic behavior of the system. Among these strategies the theory of optimal controls linear (LQR) [7]. The Figure I.9. shows simple block diagram to explain how the active suspension can achieve better performance.

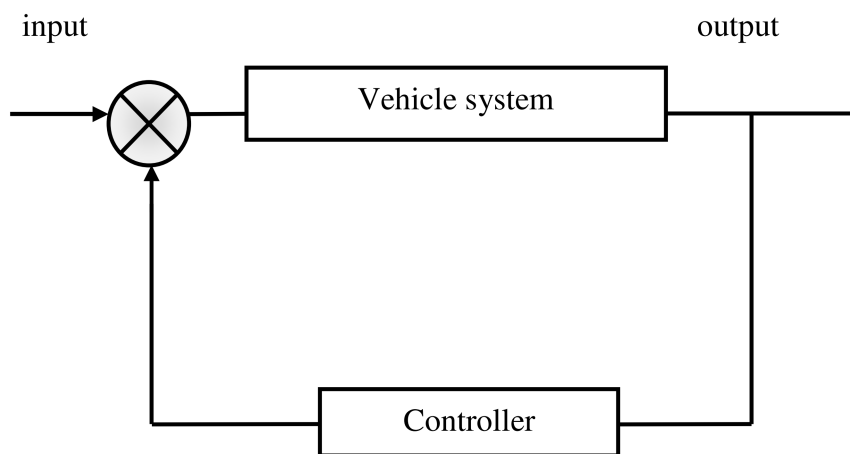

Figure I.9 Active suspension of control system

I.11 The method of the optimal control LQR linear

This theory allows to obtain, under some constraints the optimum of controller, to the extent where the vector of state, the vector of controller and the vector of disturbance, are linked by a relationship of type:

$$\dot{X} = A X + B U + D W \quad (\text{I.6})$$

Where

$X(t)$ = vector of state

$U(t)$ = vector of command

$W(t)$ = vector of disturbance assumed to be white noise of zero mean and covariance matrix K .

A , B and D are matrices extracted constants of differential equations that define the system.

The aim being to minimize performance index J defined in the following:

$$J = J_1 + \rho_1 J_2 + \rho_2 J_3 + \rho_3 J_4 \tag{I.7}$$

J_1 , J_2 , J_3 and J_4 are factors respectively related on comfort, the race of the suspension, the handling and to the cost of operation.

ρ_1 , ρ_2 and ρ_3 are factor loadings.

This index of performance J can write in the form:

$$J = E \left\{ X^T \cdot U^T \cdot \begin{bmatrix} Q & N \\ N^T & R \end{bmatrix} \cdot \begin{pmatrix} X \\ U \end{pmatrix} \right\} \tag{I.8}$$

Where

$$J = E \{ X^T Q X + U^T R U + 2 X^T N U^T \} \tag{I.9}$$

E indicates the expectation.

The matrices Q and R are symmetrical. Q is definite non negative and R is definite positive.

The resolution of the problem consists in determining the command U which minimizes the index of performance J . This command is linear, and is worth:

$$U = -K \cdot X \tag{I.10}$$

Where K is the matrix profit of command, given by :

$$K = B^{-1} (N^T + B^T S) \tag{I.11}$$

Such as, S matrix symmetric defined positive, solution of the equation of RICCATI which is:

$$S \cdot A + A^T \cdot S - (S \cdot B + N) R^{-1} \cdot (B^T S + N^T) + Q = 0 \tag{I.12}$$

The Figure I.10 shows simple block diagram of **LQR** control schematic

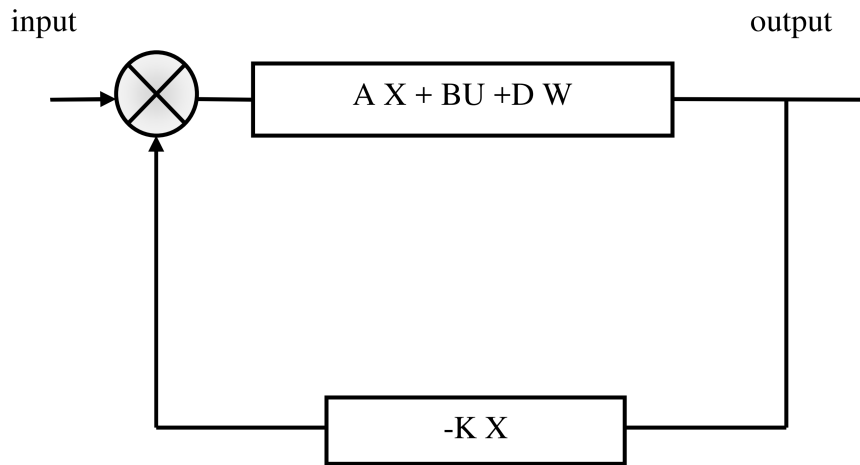

Figure I.10 Block diagram of LQR control schematic

I.12 Functions of inputs

To see the various answers of our system, one excites it by the three functions of excitation, sinusoidal, impulse and echelon [12]

I.12.1 Excitation sinusoidal

The function of sinusoidal excitation is given by

$$W(t) = w_0 \sin(\omega_n t) \quad (\text{I.13})$$

With

w_0 = maximum amplitude of excitation.

ω_n = pulsation of the system in rad/s.

I.12.2 Excitation impulse

The function impulse is given by the expression

$$W(t) = w_0 \left(\frac{\exp(-2)}{4} \right) (\nu \omega_n t)^2 \exp(-\nu \omega_n t) \quad (\text{I.14})$$

With

V = factor of severity of shock.

ω_n = pulsation of the system in rad/s.

w_0 = maximum amplitude of signal (m).

I.12.3 Excitation echelon

The function echelon is given by the expression

$$W(t) = w_0 [1 - \exp(-V \omega_n t) (1 + V \omega_n t)] \quad (\text{I.15})$$

ω_n = pulsation of the system in rd/s.

W_0 = maximum amplitude of input.

V = factor of severity of shock

Conclusion

In this chapter, one has defines different the type of suspension of vehicle passive, semi-active and active, as well as degrees of freedom of a quarter , half and full vehicle , on the other hand, the input functions sinusoidal, impulse and echelon which will be used as functions of excitation of the system of suspension .

The optimization of the active suspension by a control law of LQR supposes that the system is linear and that the disturbance is a white vibration of average zero , which is not always the case, because actually the profile of the road is unspecified and the dynamic behavior of the vehicle is not rigorously linear.

The need to develop new systems of suspensions more reliable and more powerful pushed the researchers to find new methods of command for the regulation of non-linear systems, which will be the subject of the developments of the following chapters.

Chapter II:

Fuzzy control of an active
suspension to a degree of
freedom

II.1 Introduction

The fuzzy logic, whose elementary theory was established in 1965 at the University of Berkeley (California) by the Pr. Lotfi A. Zadeh, is a concept based on a linguistic formulation of the human reasoning [8]. Its application on to the control was not possible that in 1974 thanks to the work of the Pr. E. H. Mamdani which designed and produced the first regulator by fuzzy logic.

Fuzzy logic methods can be utilized in many ways in controlled suspension systems. With appropriate membership functions and rule bases it considered to be insensitive to model. Fuzzy logic is a method of controlling a system where all input conditions are not well defined. The implementation of fuzzy logic allows the use of rule based control where by the controller is defined by abstract that give them a fuzzy quality. The linguistic control strategy of the fuzzy algorithm serves as a fuzzy process model, because of the linguistic statements from the rule base of the fuzzy logic controller, the control strategy resembles human thinking process application of fuzzy logic method is presented [17].

We will consider in this chapter the model of active suspension of the **figure .I.4.** to which we will apply a fuzzy control developed starting from a regulator of the Mamdani type.

II.2 Linguistic variable

A linguistic variable represents a state in the system to be regulated or a variable of adjustment in a fuzzy controller. Its value is defined in linguistic terms which can be words or sentences of a natural or artificial language.

Each variable linguistics is characterized by a set such as [14]:

$$\{ X, T(X), u, G, M \} \quad \text{II.1}$$

with

X = the name of the variable

$T(X)$ = the linguistic values which X can take

U = universe of discourse associated with the basic value

G = syntactic rule to generate the linguistic values of X

M = semantic rule to associate a direction with each linguistic value

For example

The variable linguistics X ambient temperature can be defined with a set of terms

$T(X) = \{\text{extremely cold, very cold, cold, hot, veryhot and extremely hot}\}$

Who form his universe of the discourse $U = [-20^{\circ}\text{C}, 40^{\circ}\text{C}]$.

The basic variable X is temperature.

The term cold represents a linguistic value.

II.3 Membership function

Each fuzzy subset can be represented by its function of membership. If the set of reference is a finished unit, the values of membership are values discrete defined in $[0, 1]$.

If the set of reference is infinite, one can represent these values like functions of membership continuous.

In general, there are different forms of membership functions such as singleton(a), triangular (b), trapezoidal (c), and Gaussian the shape of bell as the form (d) shows in Figure.II.1. [16]

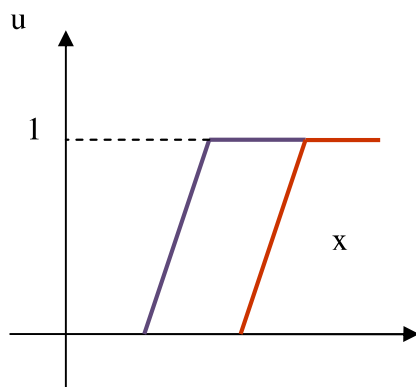

(a)

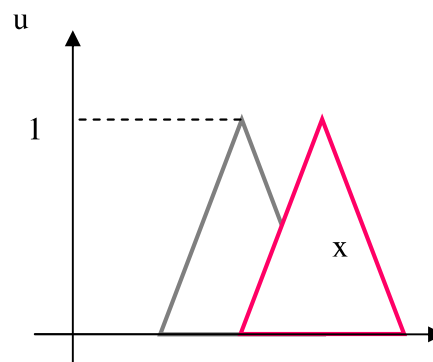

(b)

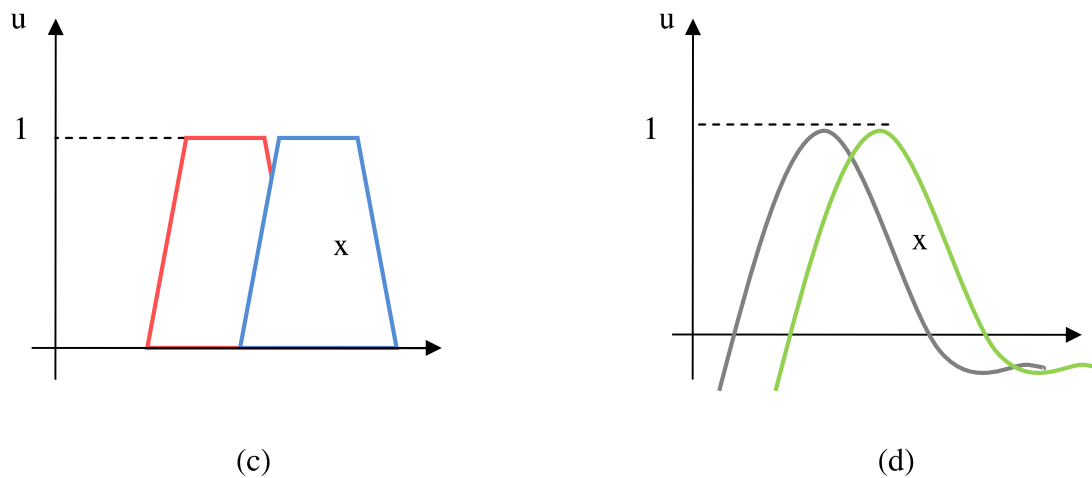

Figure II.1 Various forms of membership function

II.4 Universe of the discourse

One of the first steps in the design of a fuzzy application is to define the subset of reference or universe of the discourse for each linguistic variable [14].

II.5 Linguistic rules

Principal the idea of the system based on fuzzy logic is to fast knowledge human in the forms of linguistic rules of forms **If...then**. Each rule has two shares [14]

- Previous part (condition), expressed by **IF**.
- Consequent expressed by then leaves.

ZADEH was the first to introduce the concept of fuzzy rule in the forms:

if X is A, **then** is B there.

II.6 The regulator of Mamdani type

Fuzzy mamdani type method turns to be an ideal approach to quicken the decision making process via converting complex equations to linguistic rules. All design factors compose input variables, and the corresponding weights and input values are produced from professional knowledge, industrial experience and product requirements.

After all input variables going through the fuzzy inference mechanism, a single recommendation score will be generated as output. According to the recommendation score of every designing scheme, developing engineers will have theoretical support to decide whether timing belt or timing chain is more preferable [15].

II.6.1 The structure of the regulator of Mamdani type

The structure of a system regulated by fuzzy logic consists of three principal blocks: the regulator by fuzzy logic [8], the control unit and the system to control figure.II.2.

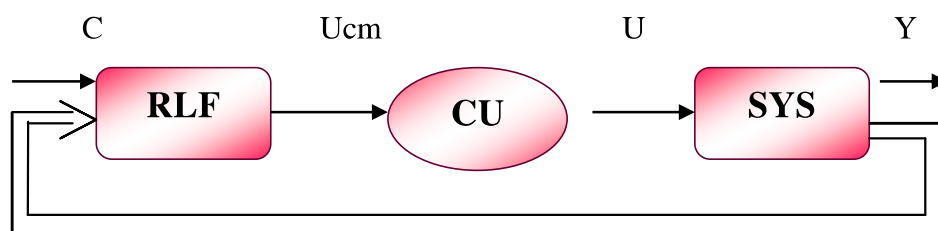

Figure II.2 Schematic diagram of the adjustment by fuzzy logic

II.6.2 Structure of fuzzy logic controller

The regulator by fuzzy logic (RLF) does not treat a mathematical relation well defined, but uses inferences with several rules, being based on linguistic variables [11].

In figure II.3. we will present the general procedure of the design of a regulator by fuzzy logic. The basic configuration of a logical regulator fuzzy **RLF** comprises four principal blocks

- The block of fuzzification
- The block of inference
- Knowledge bases
- The block of defuzzification

The process of fuzzy logic controller is illustrated in figure II.3

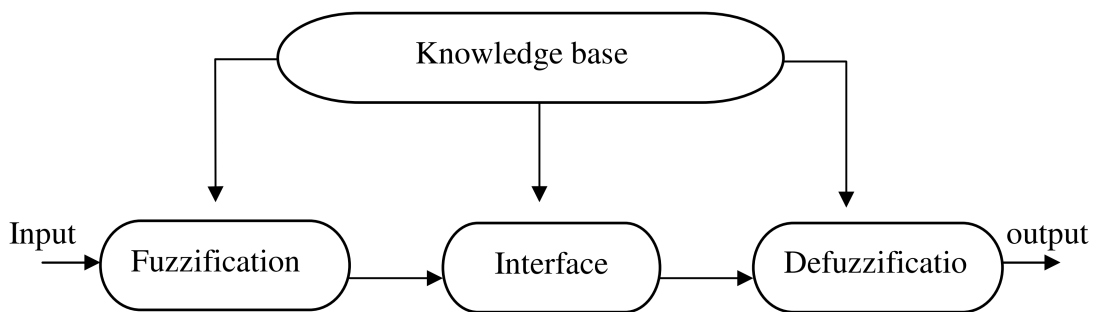

Figure II.3 Diagram of fuzzy logic controller

II.6.3 Internal structure of fuzzy logic controller

The structure of the regulator by fuzzy logic applied to our system of suspension is represented on the figure II.4

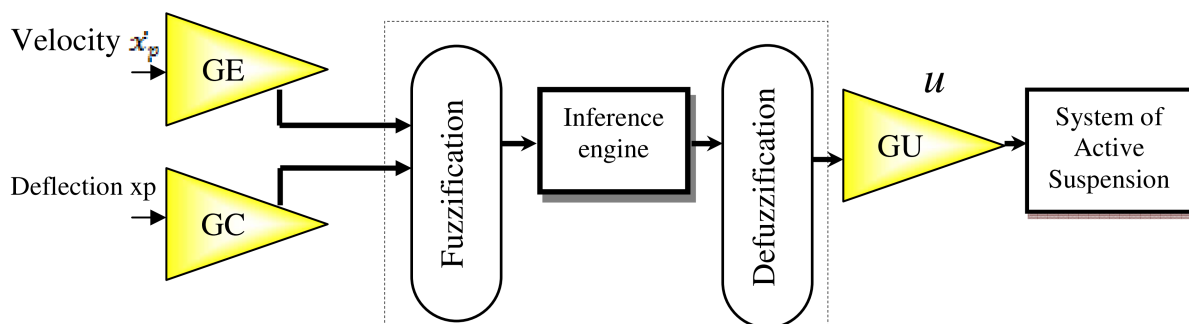

Figure II.4 Internal structure of the regulator by fuzzy Logic

x_p and \dot{x}_p are the input variables of the regulator by fuzzy logic. They correspond respectively to the deflection and the velocity.

u is the output. It represents the control force applied by the actuator.

GE, **GC** and **GU** are gains applied respectively to the deflection, the velocity and the control force, that values taken by these latest do not exceed the universe of the discourse [9].

II.6.4 The role of logical regulator fuzzy (RLF)

The roles of each block can be summarized as follows [11]

- The **Fuzzification** block carries out the following functions
 - Establishes the ranges of values for the membership function starting from the value of the input variables.
 - Carry out a fuzzification function with converts the input data into suitable linguistic value .
- The **bloc knowledge** base is composed of the subsets of the information which we have on the process. It makes it possible to defined the membership function and the rules of the fuzzy regulator.
- The **bloc inference** is the heart of the regulator, which has the capacity to simulate the human decisions and deduce fuzzy control actions implication and the rules of inference.
- The **defuzzification** block carries out the following functions
 - Establishes the ranges of values for the membership function starting from the value of the output variables signal from the deduced fuzzy signal .
 - Carry out defuzzification which provides a control signal not fuzzy starting from the deduced fuzzy logic.

II.7 Procedure of fuzzy reasoning

II.7.1 Bloc of fuzzification

The inputs in a fuzzy regulator are in general measured using bodies of measurement who are more are of analogical type, The attribution of degrees of membership of each value of input is a passage of the physical sizes to the linguistic variables, the linguistic variables are indicated by their linguistic values .

In general, the functions of membership which represent the linguistic values are defined in triangular, trapezoidal form or in the shape of bell.

One can introduce for a variable X three, five or seven linguistic values.

On the other hand, such a choice would complicate the formalization of the rules of inference.

The standard designation of the fuzzy set is NB negative big, NM negative medium, NB negative small, ZE zero, PB positive big, PM positive medium , PS positive small. A number of linguistic values higher than seven does not bring any in general improvement of the dynamic behavior of the adjustment.

On the other hand, such a choice would complicate the formalization of the rules of inference.

II.7.2 Bloc of inference

The inference bind the measured sizes and the variables of output by linguistic rules.

These rules are combined by using connections ” **and** ” and “ **or** ” . Let us suppose that it fuzzy system has two inputs suitably transformed into linguistic variables X, Y and an output Z, and which one defined N linguistic rules as follows [14]

If $x=A_1$ and $y=B_1$ **then** $z=C1$

If $x=A_2$ and $y=B_2$ **then** $z=C2$

In other words, in a general way, we write

If $x=A_n$ and $y=B_n$ **Then** $z=Cn$.

II.7.3 Defuzzification

The result of a fuzzy inference is a membership function . It is a fuzzy subset a control unit requires a precise control signal.

The transformation of fuzzy information in to given information is defuzzification.

There are several methods of defuzzification suggested in the literature. There is no strategy .

To choose among one of these methods [14]

- method of the centre of gravity
- method of the average of the maximums
- method of TSUKAMOTO method of the weighted average

The method of the most used defuzzification, is that based on the determination of the **centre of gravity** of the function of membership resulting from all the rules of inference [4]

$$u(t) = \frac{\int_{-x}^{+x} x_R \cdot U_{RES}(x_R) \cdot dx_R}{\int_{-x}^{+x} U_{RES}(x_R) \cdot dx_R} \quad \text{or} \quad u(t) = \frac{\sum \mu_i(u) \cdot dx_R}{\sum \mu_i(u)} \quad (\text{II.2})$$

$U(t)$ = membership function

U = variable of output

The final control signal applied to the suspension is given by

$$U(t) = GU \cdot u(t) \quad (\text{II.3})$$

The integral with the denominator gives surface, while the integral with the numerator corresponds at the time of surface.

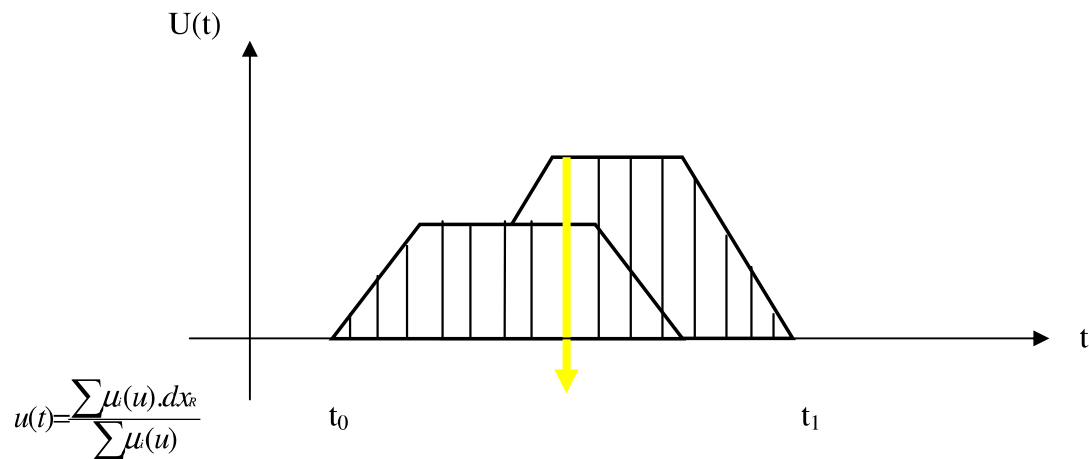

Figure II.5 Deffuzification by the method of the centre of gravity

II.8 Advantages and disadvantages of fuzzy logic controller :

The control of a system by fuzzy logic present has the time of the advantages and the disadvantages of which we quote mainly the following points [14]:

Advantages

- Not required establishment of a mathematical model of the system to be regulated
- Implementation of knowledge of the operator of the process
- Possibility of controlling systems nonlinear and difficult to model

Disadvantages

- Lack of precise directives for the design of a regulator
- Artisanal and non systematic approach
- Impossibility of showing the stability of the circuit of adjustment in any general information
- Precision of the adjustment relatively low
- Coherence and inference unguaranteed a priori

II.9 The controller by fuzzy logic

II.9.1 Fuzzification of variable (the inputs of the RLF)

Its role consists in converting the numerical values of the variables of the input in to Linguistic variables (fuzzy).

The two **inputs** as well as the **output** are fuzzified values in 7 linguistic variables are

- **NB** : negative big
- **NM** : negative medium
- **NS** : negative small
- **ZE** : zero
- **PB** : positive big
- **PM** : positive medium
- **PS** : positive small

The generalized bell membership function is specified by three parameters has three functions name **gbellmf** [16].

The fuzzification is gives thanks to the membership functions of Gaussian shape generated by the formulated [9]:

$$w_{ii}(x, a_i, b_i, c_i) = \frac{1}{1 + \left[\left[\frac{x - c_i}{a_i} \right]^2 \right]^{b_i}}$$

(II.3)

With

a_i = length of the field of the bell

b_i = Declines in both sides of the bell

c_i = Position of the top of the bell

The set $\{a_i, b_i, c_i\}$ constitutes the parameters of the adjustment associated with the various linguistic variables of the controller by fuzzy logic.

The settings chosen for the membership functions are [9]

The functions bells associated with .Table II.1.a, .II.1.b and .II.1.c respectively are illustrated by the figures .II.6.a , .II.6.b and .II.6.c

II.9.1 .1 The deflection x_p

Table. II.1.a

	$\{a_i, b_i, c_i\}$
NB	{5.0, 1.5, -6.0}
NM	{2.0, 1.5, -3.0}
MS	{2.0, 1.5, -1.0}
ZE	{2.0, 1.5, 0.0}
PS	{2.0, 1.5, 1.0}
PM	{2.0, 1.5, 3.0}
PB	{5.0, 1.5, 6.0}

Table II.1.a The parameters of the membership function of the deflection x

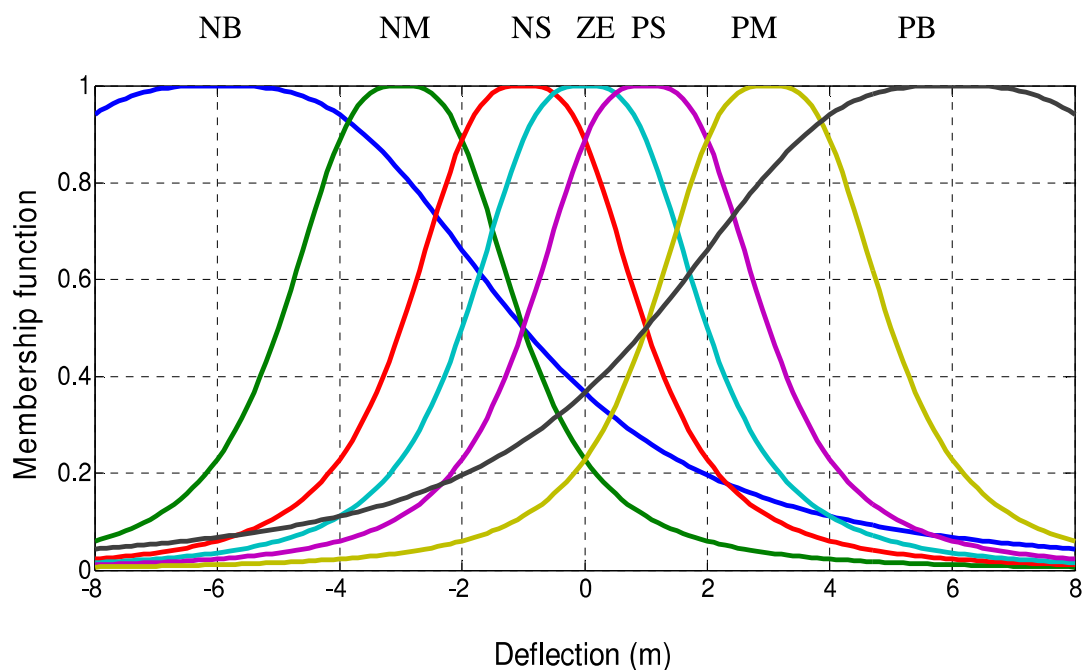

Figure II.6.a The membership function of the input variable of the deflection

II.9.1 .2 The velocity \dot{x}_p

Table. II.1.b

	$\{a_i, b_i, c_i\}$
NB	{2.0, 1.5, -6.0}
NM	{2.0, 1.5, -3.0}
MS	{2.0, 1.5, -1.0}
ZE	{2.0, 1.5, 0.0}
PS	{2.0, 1.5, 1.0}
PM	{2.0, 1.5, 3.0}
PB	{2.0, 1.5, 6.0}

Table II.1.b The parameters of the membership function of the velocity \dot{x}_p

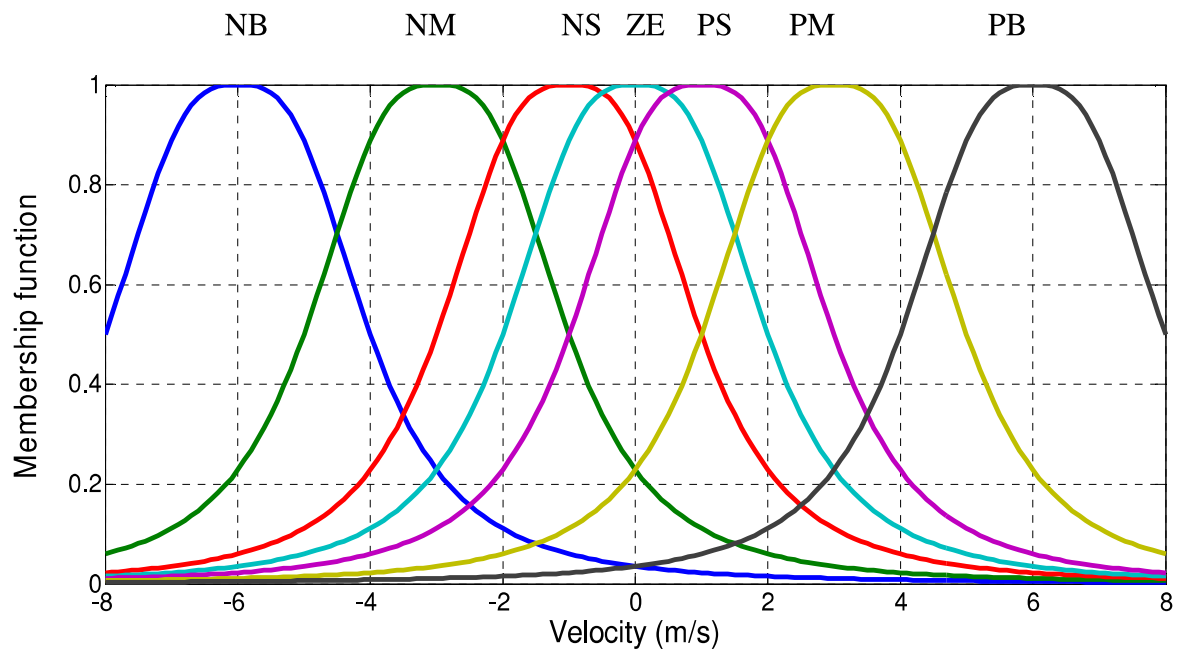

Figure II.6.b The membership function of the input variable of the velocity

II.9.1 3.The force U

Table. II.1.c

	$\{a_i, b_i, c_i\}$
NB	{5.0, 1.5, -37.5}
NM	{2.0, 1.5, -25.0}
MS	{2.0, 1.5, -12.5}
ZE	{2.0, 1.5, 0.0}
PS	{5.0, 1.5, 12.0}
PM	{5.0, 1.5, 25.0}
PB	{5.0, 1.5, 37.5}

Table II.1.c The parameters of the membership function of the force u

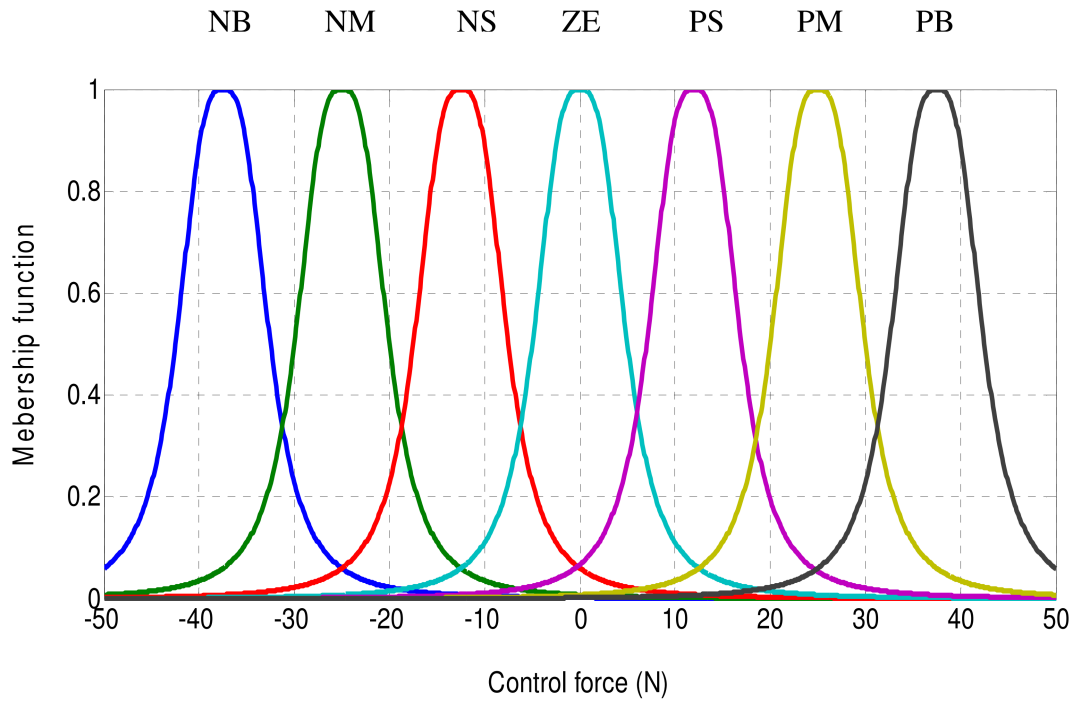

Figure II.6.c The membership function of the output variable of the control force

Comparison of the membership function of the input and output variables

- The deflection x , the velocity \dot{x} and the control force u of the membership function of the input and output variables represented by the figures II.4.a, II.4.b, II.4.c. thanks to the control of fuzzy logic.
- The figures II.4.a, II.4.b we see the membership function of the input has always the same shape.
- Fuzzy logic system (FIS) can be defined as the non-linear system of an input set data to scalar output data.
- The membership function is always limited to between 0 and 1, also known as a membership value or membership grade.
- The deflection and the velocity of suspension mass we associated the linguistic terms {NB, NM, NS, ZE, PB, PM, PS}, and control force u defined in this typical case on the interval $[-50, 50]$. As for the variable of output represent by the force u , we taken only seven fuzzy subsets {NB, NM, NS, ZE, PB, PM, PS} defined on a control force ranging from $[-8, 8]$.
- All two-input single-output (TISO) models observe the same assumptions and identical constrains. Similar characteristics of membership function are discussed in this chapter, including overlap ratios between membership functions, the shape of membership functions and the quantity of membership functions for describing a single input variable or output variable [15].

II.9.2 Base of the rules

The block of control is made of a set of linguistic rules binding the variables of input to the variables of output, of the type **IF** {condition}; **THEN** {sequence} [8].

The rules of inference influence directly the control generated by the regulator. The wise choice of these rules is essential for the good performance of the regulator.

The base rules applied to our controller by fuzzy logic is given by the Table II.2 [9]

Table II.2 Base rules for the controller by fuzzy logic

		Velocity \dot{x} (m/s)						
		NB	NM	NS	EZ	PS	PM	PB
Deflection x_p (m)	NB	NB	NB	NM	NS	NS	NS	ZE
	NM	NB	NM	NS	ZE	NS	ZE	PS
	NS	NM	NS	ZE	ZE	ZE	PS	PM
	ZE	NM	NS	ZE	ZE	ZE	PS	PM
	PS	NM	NS	ZE	ZE	ZE	PS	PM
	PM	NS	EZ	PS	ZE	PS	PM	PB
	PB	EZ	PS	PS	PS	PM	PB	PB

The rules which this table describes are (form symbolic system)

If (deflection is NB) and (velocity is NB) **then** (control-force is NB)

If (deflection is NB) and (velocity is NM) **then** (control-force is NB)

If (deflection is NB) and (velocity is NS) **then** (control-force is NS)

If (deflection is NB) and (velocity is EZ) **then** (control-force is NS)

The control of output u at every moment t is given by

$$u(u(t)) = F \left[u \left(GE.x_p(t) \right), u \left(GC.\dot{x}_p(t) \right) \right] \quad (\text{II.4})$$

With

F =Relation between the parameters of input and output which is defined by the rules of inference. For our regulator we will use the method of inference **max-min**.

In general it is made use of the one of the following methods

- Method of inference max-min
- Method of inference max-prod
- Method of inference sum-min

Conclusion

The theory of fuzzy logic or the application of a FLC (Fuzzy logic to control) is one very effective and simple means of use to optimize the control of the active suspensions using the fuzzy rules and variables and with the programming under the software MATLAB using Toolbox Fuzzy logic.

Chapter III:

Simulation of an active
suspension to a degree of
freedom

III.1 Introduction

In this chapter we present diagrams of the dynamic equations of sky-hook model, the active and passive suspension of a degree freedom of the quarter vehicle, we excite the system with functions of sinusoidal and echelon road profile, we register the performance criterion using the software MATLAB using Toolbox fuzzy logic.

The Fuzzy Logic Toolbox is designed to work seamlessly with simulink, the simulation software available from the math works. Once you have created your fuzzy system using the GUI tools or some other method, you are ready to embed your system directly into a simulation [15].

At the end of chapter will be compared the active and passive suspension compared to the sky-hook reference model, of each model we present each time the following parameters:

- The acceleration of the body of vehicle $\ddot{z} = \ddot{x} + \ddot{w}$
- The deflection of the body of vehicle $z = x + w$
- Deflection of wheel $x = z - w$
- Control force

III.2 The parameters of suspension

The values of the mass, of the coefficients of stiffness and damping, allotted to the systems of passive suspensions, Sky-Hook and active, refer to work of M.V.C.Rao and V.Prahlad [9].

III 2.1 The parameters of suspension and sky-hook reference

The parameters of the active, the passive suspension and the model of the skyhook reference, show in Table II.1.

Table III.1 The parameters of the active, the passive suspension and the sky-hook reference

System	The parameter	Symbol	Value	Unit
Active	masse of suspension	m_m	355	kg
	spring coefficient	b_m	1 860	Ns/m
	damping coefficient	k_m	14 384	N/m
Passive	masse of suspension	m_b	355	kg
	spring coefficient	b_b	1 860	Ns/m
	damping coefficient	k_b	14 384	N/m
Sky-hook	masse of suspension	m_p	355	Kg
	spring coefficient	b_p	3 000	Ns/m
	damping coefficient	k_p	15 000	N/m

III 2.2 The Profits used

GE=10, GC=1, GU=300.

III.3 The Flow chart of simulation

The Flow chart below illustrates the course of the digital resolution of the differential equation.

The loop will be carried out until time reaches **t = 5 sec**. The interval or increment of calculation is of **0.01 sec**. More the increment is small plus the pace of continuity and the precision of the graphs is visible.

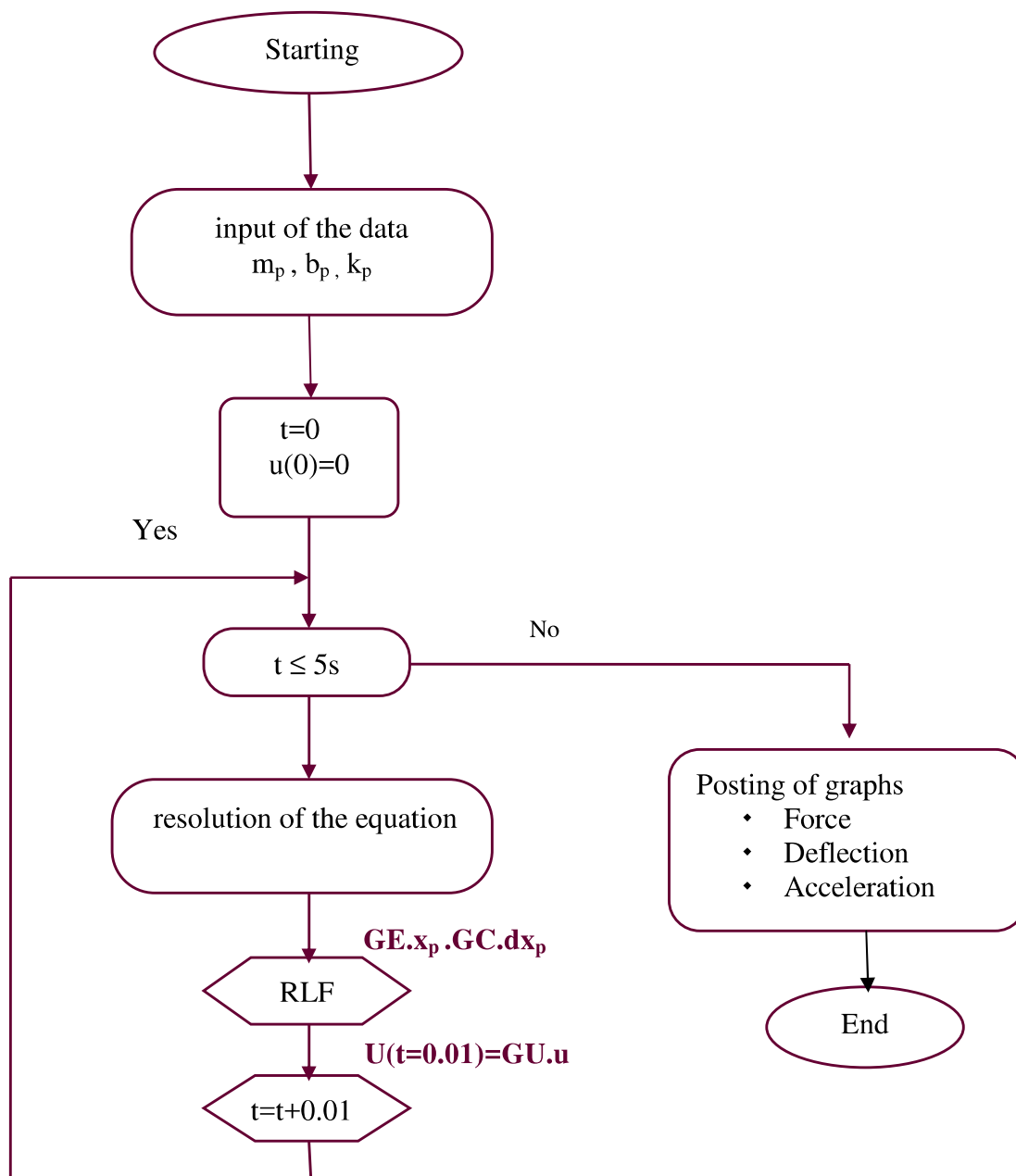

Figure III.1 Resolution of the differential equations

III.4 Response of the system to a sinusoidal road profile input

III 4.1 Profile of the sinusoidal road (disturbance)

The inputs used are illustrated below:

The results are obtained for sinusoidal input at $t = 5$ sec, and an amplitude of 0.1m.

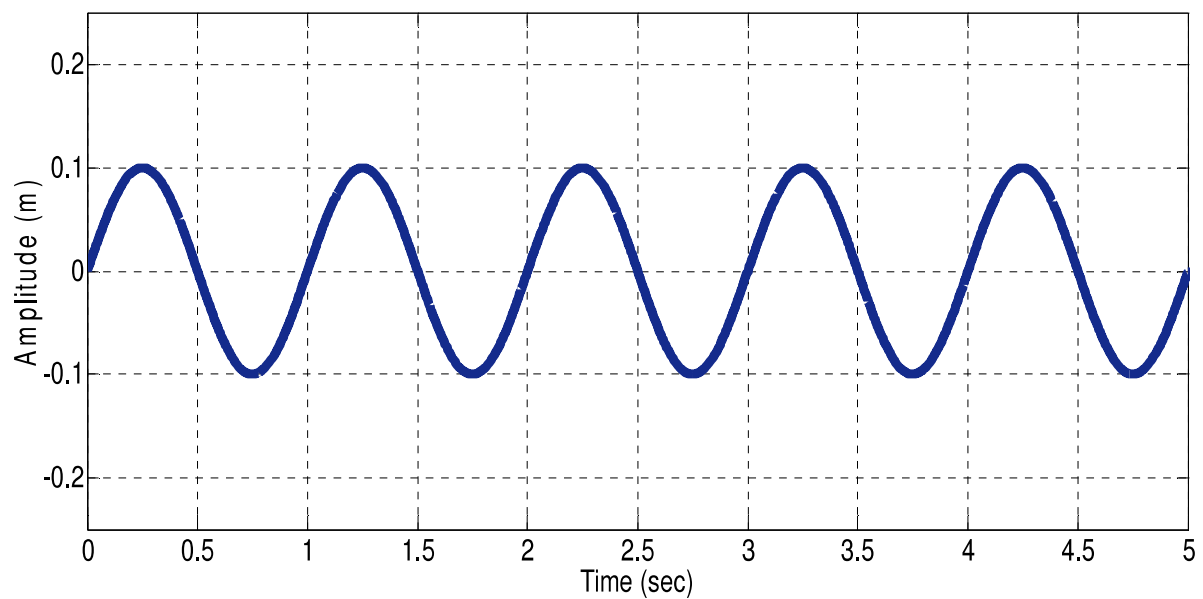

Figure III.2 Sinusoidal input

The equation of the pseudo-random input is written

$$W = 0.1 \sin(2\pi t) \quad \text{(III.1)}$$

III 4.2 Simulation of sky-Hook model

The simulation of the resolution of the dynamic equation of the sky-hook model is carried out using the simulink of the Matlab environment [10].

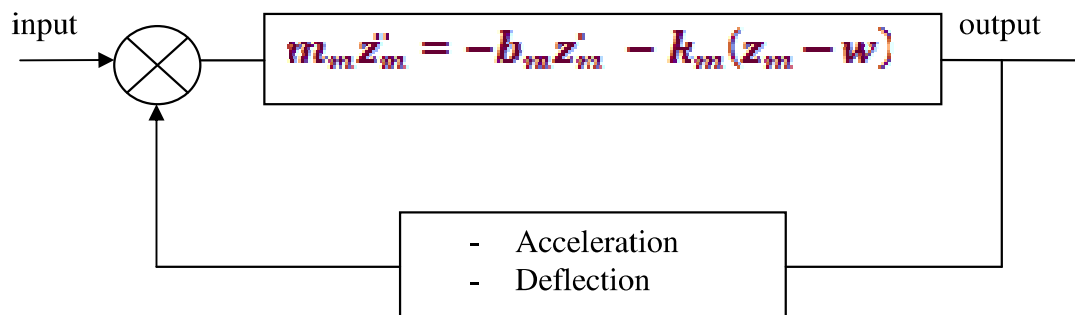

Figure III.3.a Functional Schematic of the sky-hook model

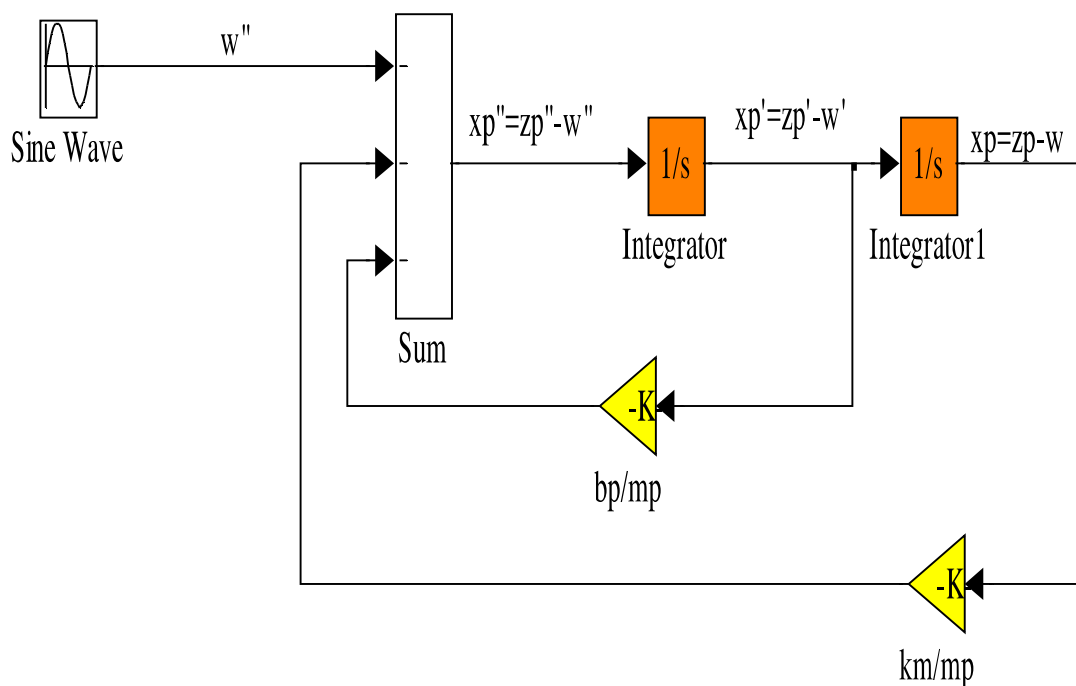

Figure III.3.b Functional diagram for the sky_hook model of simulink

III 4.3 Simulation of passive suspension

The simulation of the resolution of the dynamic equation of the passive suspension model is carried out using the simulink of the Matlab environment [10].

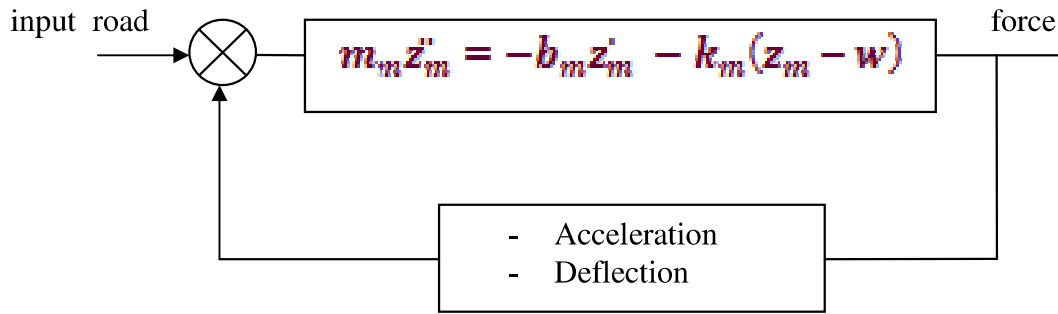

Figure III.4.a Functional Schematic of the passive suspension

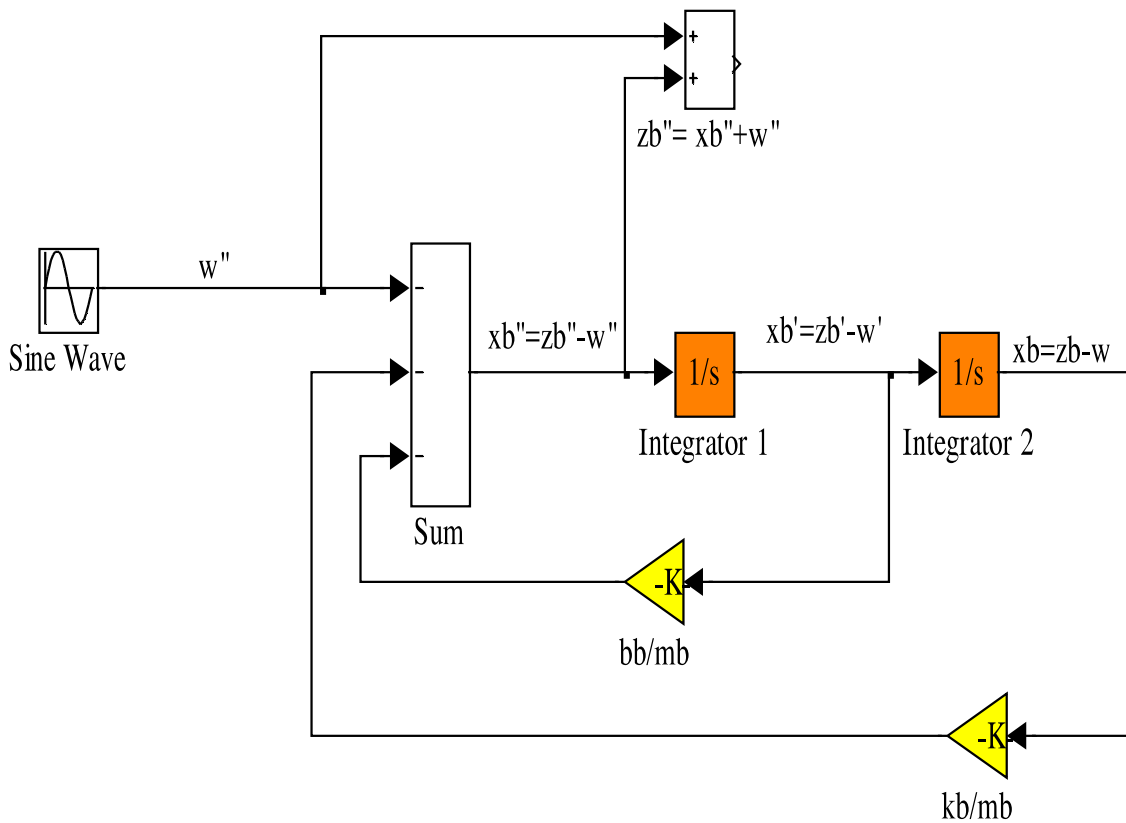

Figure III.4.b Functional diagram for the passive model of simulink

III.4.4 Simulation of active suspension

The simulation of the resolution of the dynamic equation of the active suspension is carried out using the simulink of the Matlab environment [10].

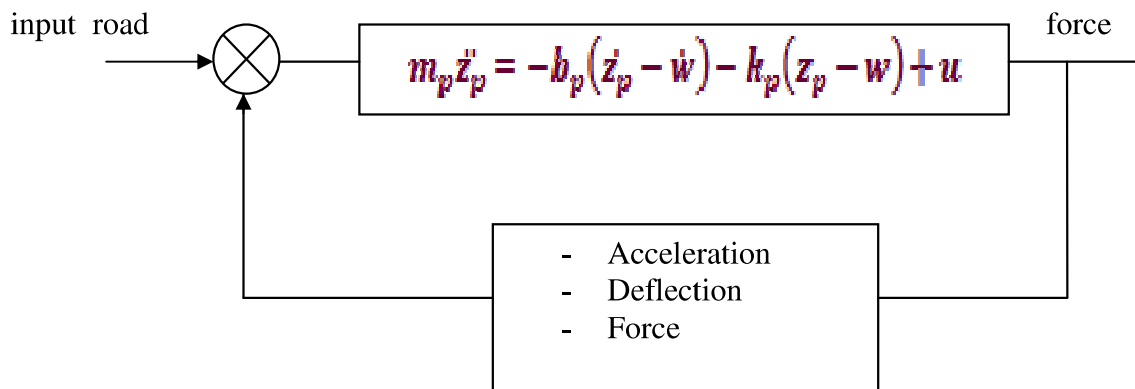

Figure III.5.a Functional Schematic of the active suspension

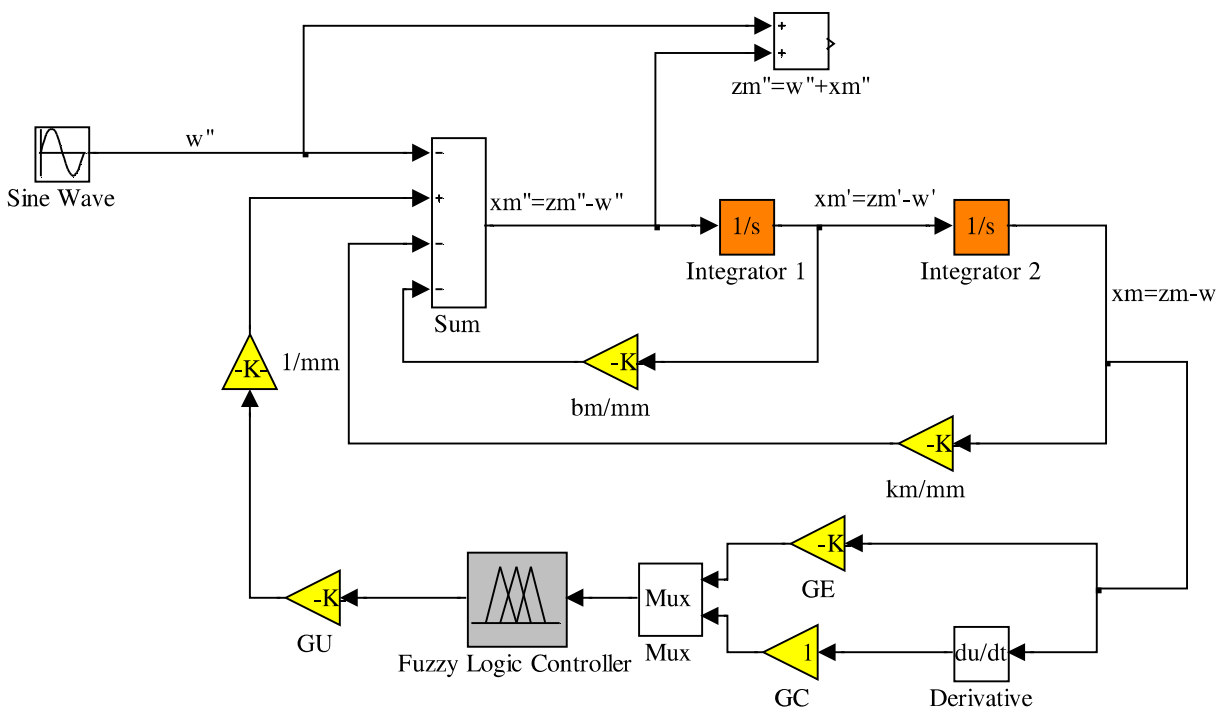

Figure III.5.b Functional diagram for active model of simulink

III 4.5 Compared of the passive suspension with the sky-hook model of reference .

III 4.5.1 Acceleration of the body of vehicle

Figure II.6.a gives us a comparison, the acceleration of the body of vehicle between the passive suspension and the sky-hook model of reference .

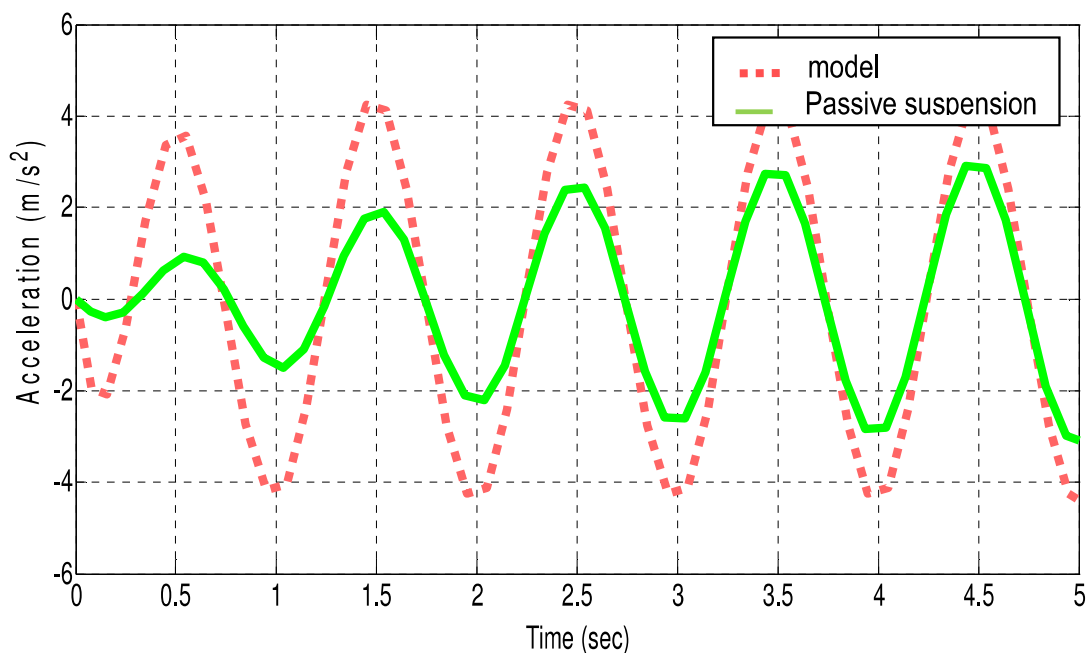

Figure III 6.a Acceleration

The accelerations of the body of vehicle of the passive suspension lower than acceleration of sky-hook model of reference , as well as in acceleration of the body of vehicle the minimum value of amplitude 1m and the minimum value of amplitude 1 m , which enables us to conclude the passive suspension is most powerful .

III 4.5.2 Deflection of wheel

As for the figure.II.6.b it compares the deflections of wheel between the passive suspension and the sky-hook mode of reference

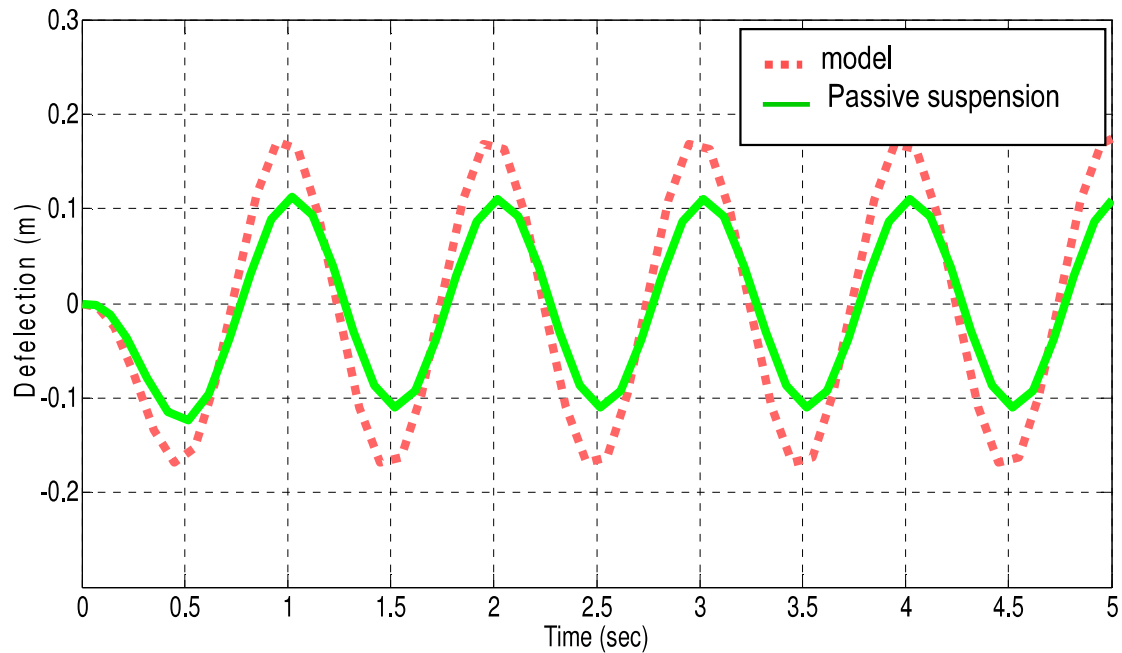

Figure III.6.b Deflection

we can see that the deflection of wheel of the passive suspension lower than the deflection of wheel of sky-hook model of reference , as well as in deflection of wheel the maximum value of amplitude 0.1 m and the minimum value of amplitude -0.1 m , which enables us to conclude the passive suspension is most powerful .

III 4.6 Compared the active suspension with the sky-hook model of reference

III 4.6.1 Acceleration of the body of vehicle

The figure .II.7. a gives us a comparison the acceleration of the body of vehicle between the active suspension and the sky-hook model of reference .

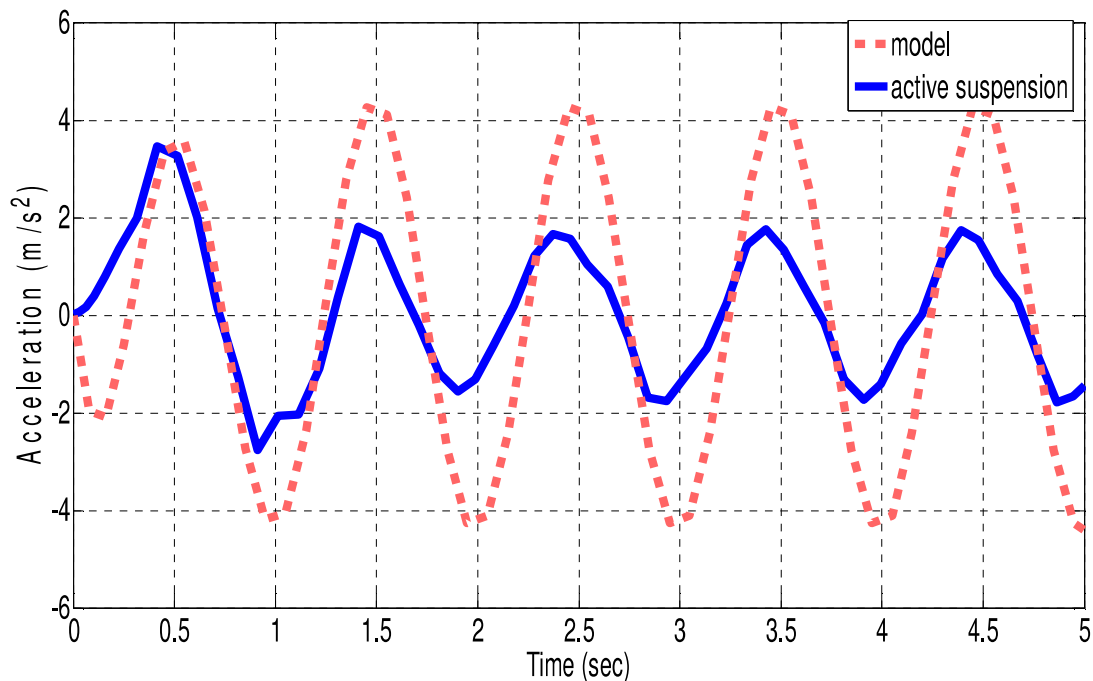

Figure III .7.a Acceleration

The accelerations of the body of vehicle of the active suspension lower than the acceleration of the body of vehicle of the sky-hook model of reference .The aim is to achieve small amplitude value for active suspension for improve a better ride comfort .

III 4.6.2 Deflection of wheel

The figure.II.7.b it compares the deflections of wheel between the passive suspension and the sky-hook model of reference.

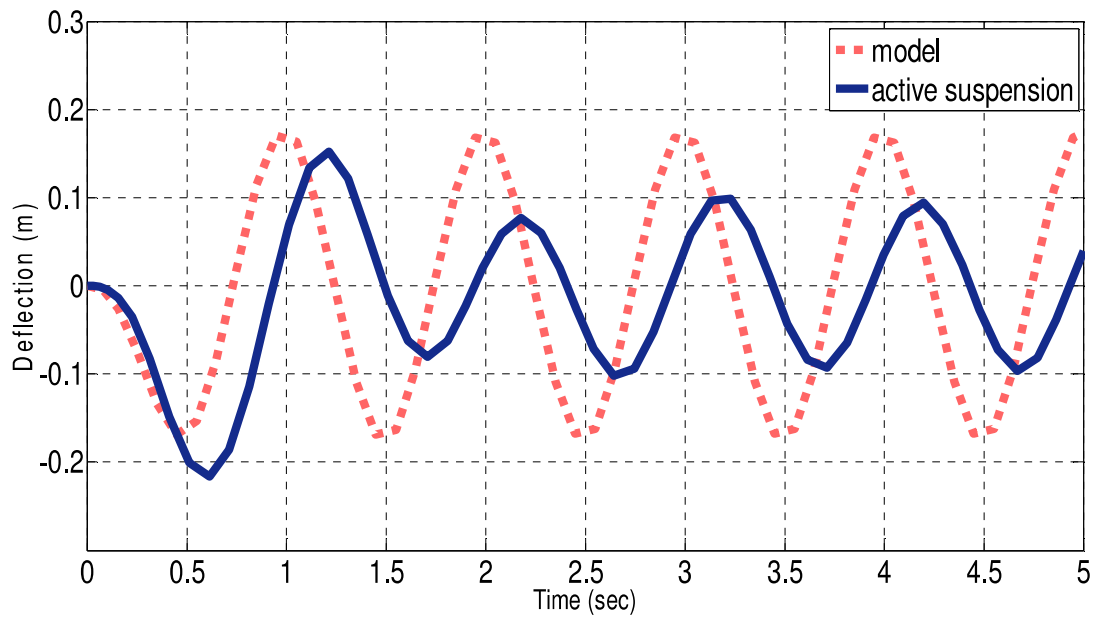

Figure III .7.b Deflection

The deflection of wheel of the active suspension lower than the deflection of the wheel of the sky-hook model of reference, the aim is to achieve small amplitude value for the active suspension for a better road holding .

III 4.6.3 Control force

The figure III.7.c represents the control force of active suspension thanks to the Controller by fuzzy logic, for following profits $GE=10$, $GC=1$, $GU=300$.

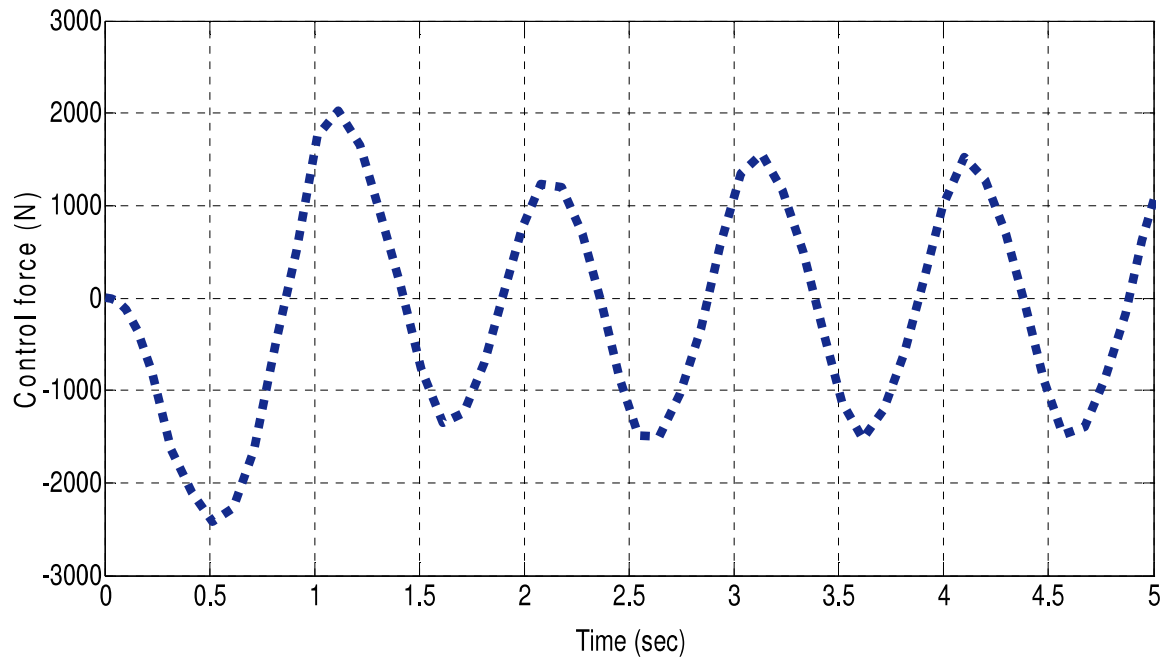

Figure III.7.c Control force

The value of amplitude of the control force is limited between $[2000, -2000]$, so the active suspension system has good performance because the control force using feedback to improve system response.

III.5 Response of the system to an echelon road profile input

III 5.1 Profile of the echelon input (disturbance)

The inputs used are illustrated below:

The results are obtained for an echelon input at $t = 5$ sec, and an amplitude of 0.1 m.

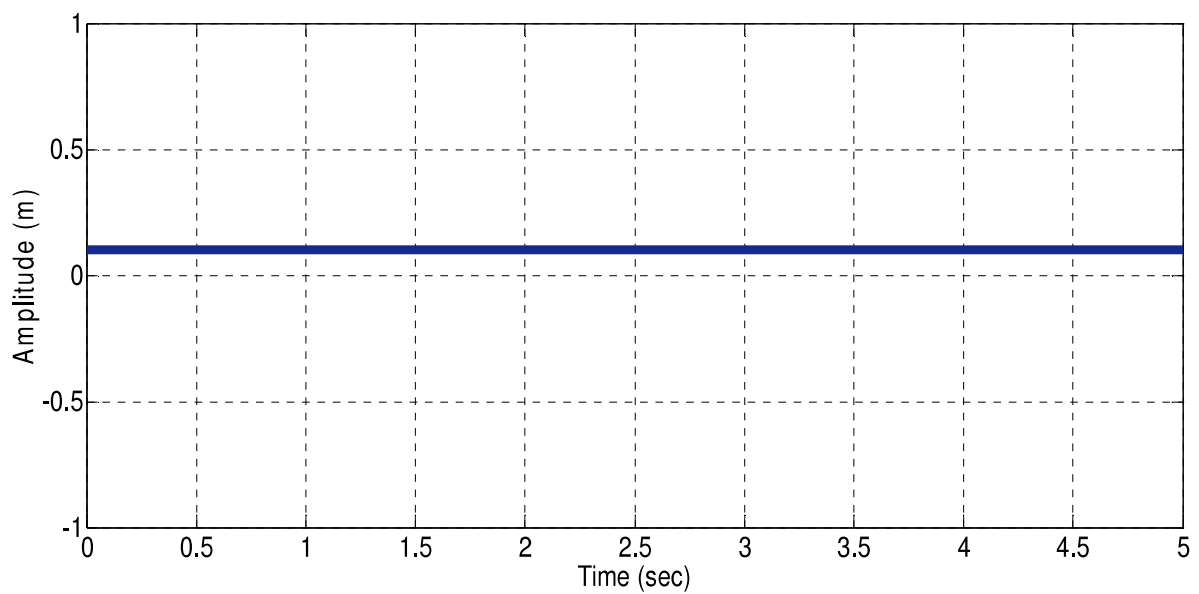

Figure III.8 Echelon input

III 5.2 Simulation of active model

The simulation of the resolution of the dynamic equation of the active suspension is carried out using the simulink of the Matlab environment [10].

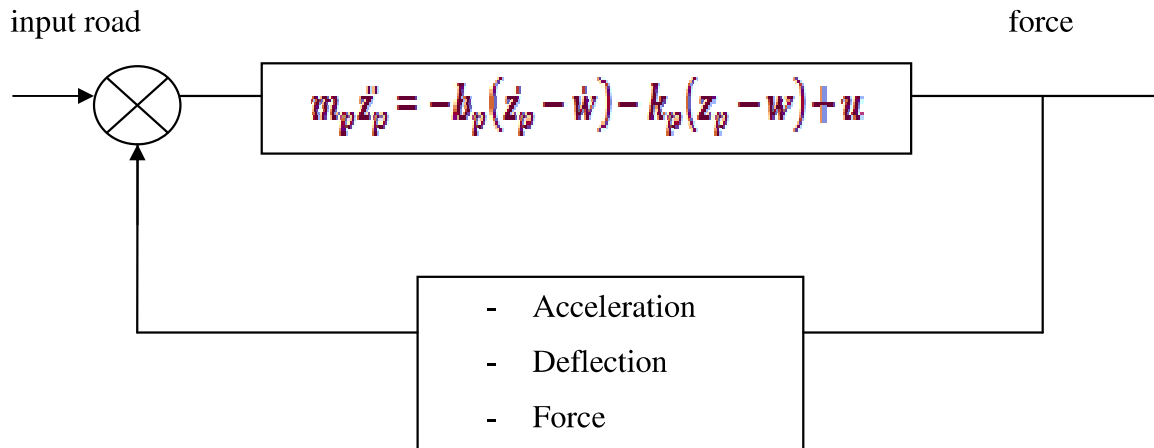

Figure III.9.a Schematic of the active suspension for simulink

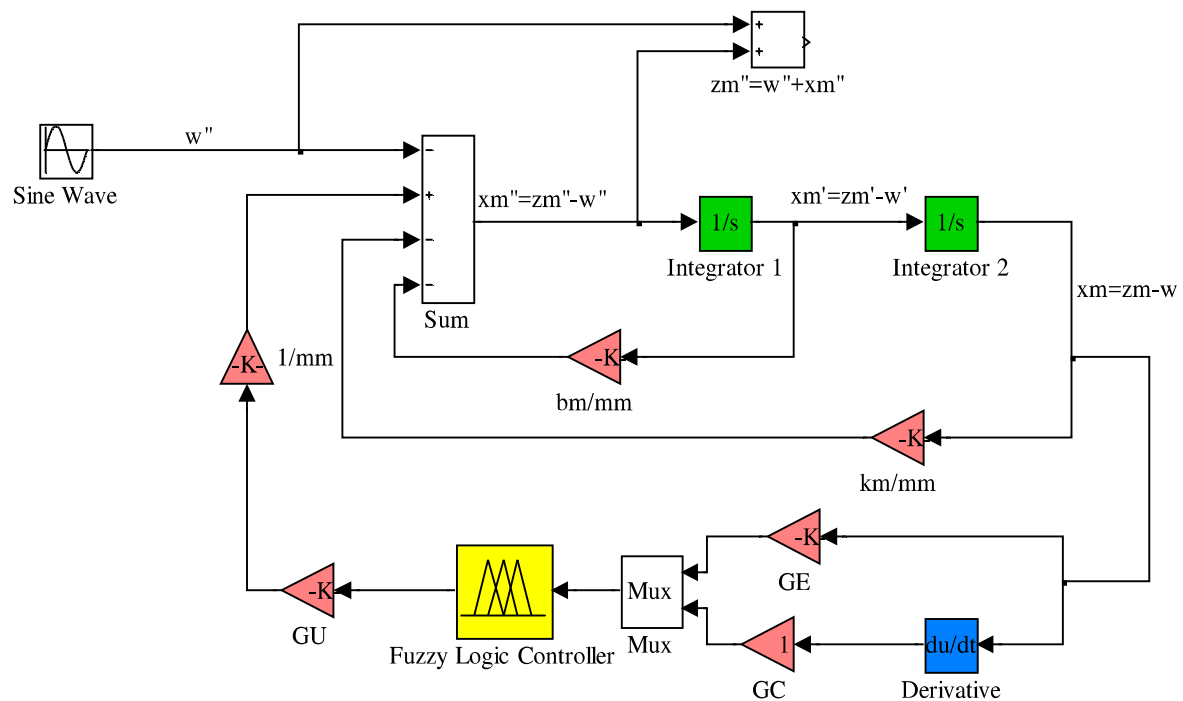

Figure III.9.b Functional diagram for active model

III 5.3 Simulation of passive suspension

The simulation of the resolution of the dynamic equation of the sky-hook model is carried out using the simulink of the Matlab environment [10].

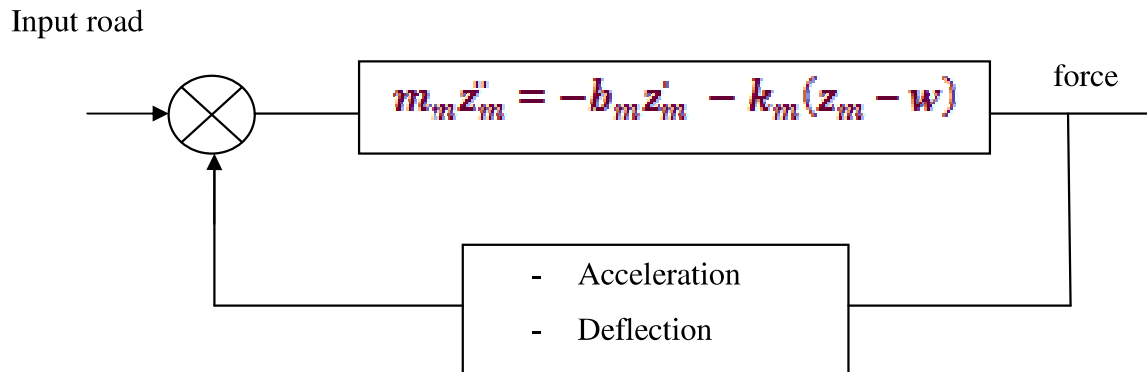

Figure III.10.a Schema of the passive suspension for simulink

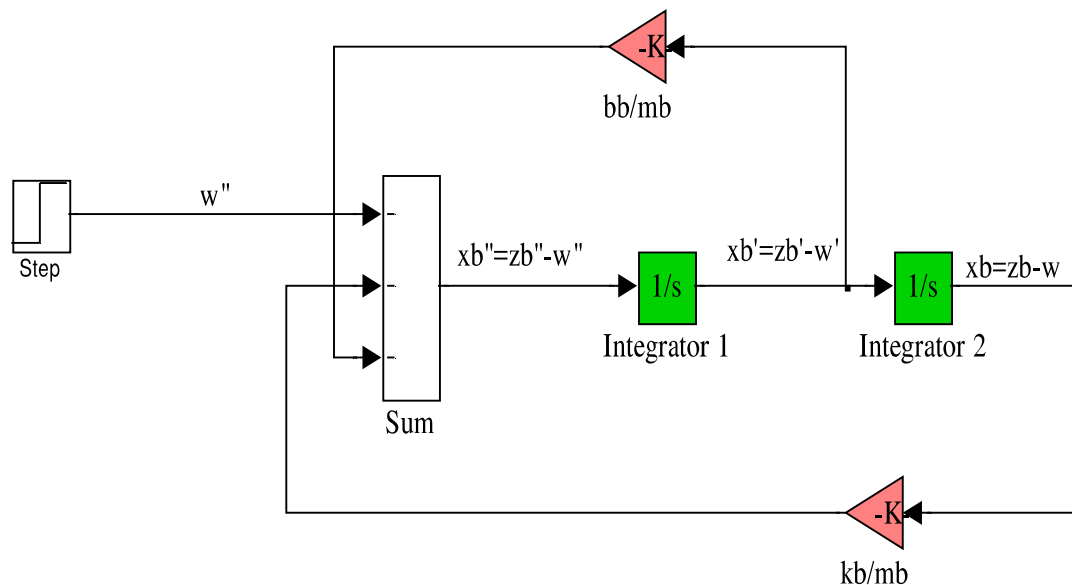

Figure III.10.b Functional diagram for the passive model

III 5.4 Simulation of sky-Hook model

The simulation of the resolution of the dynamic equation of the passive suspension is carried out using the Simulink of the Matlab environment [10].

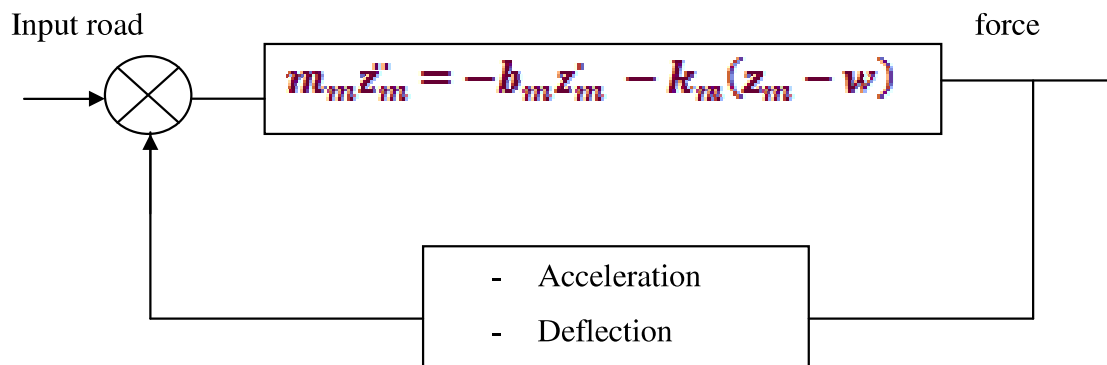

Figure III.11.a Schema of the passive suspension for Simulink

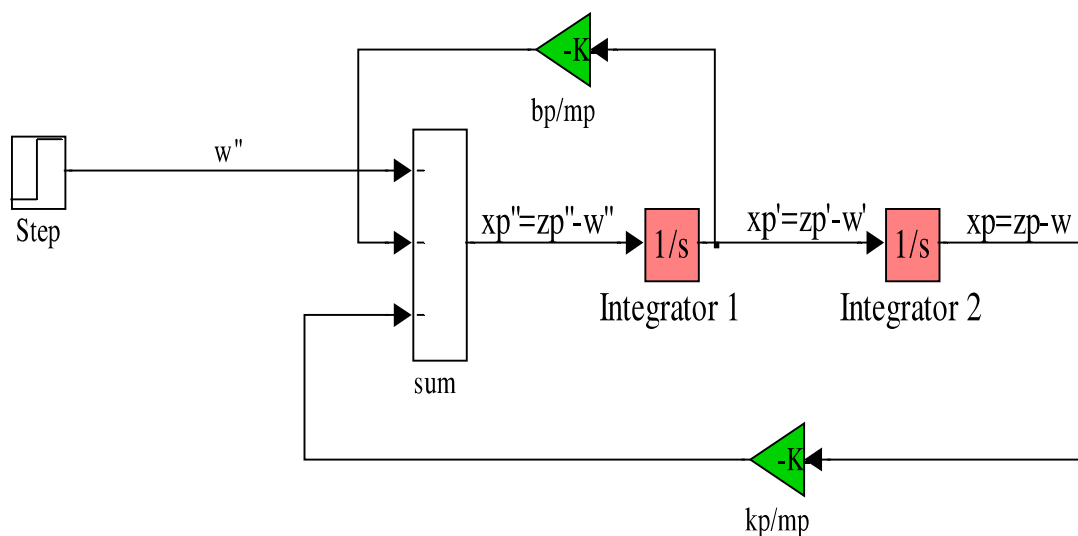

Figure III.11.b Functional diagram for the sky_hook model

III 5.5 Compared the passive and the active suspension with to the model of reference

III 5.5.1 Acceleration of the body of vehicle

Figure II.12. a gives us a comparison, the acceleration of the body of vehicle between the passive and the active suspension with the sky-hook model of reference .

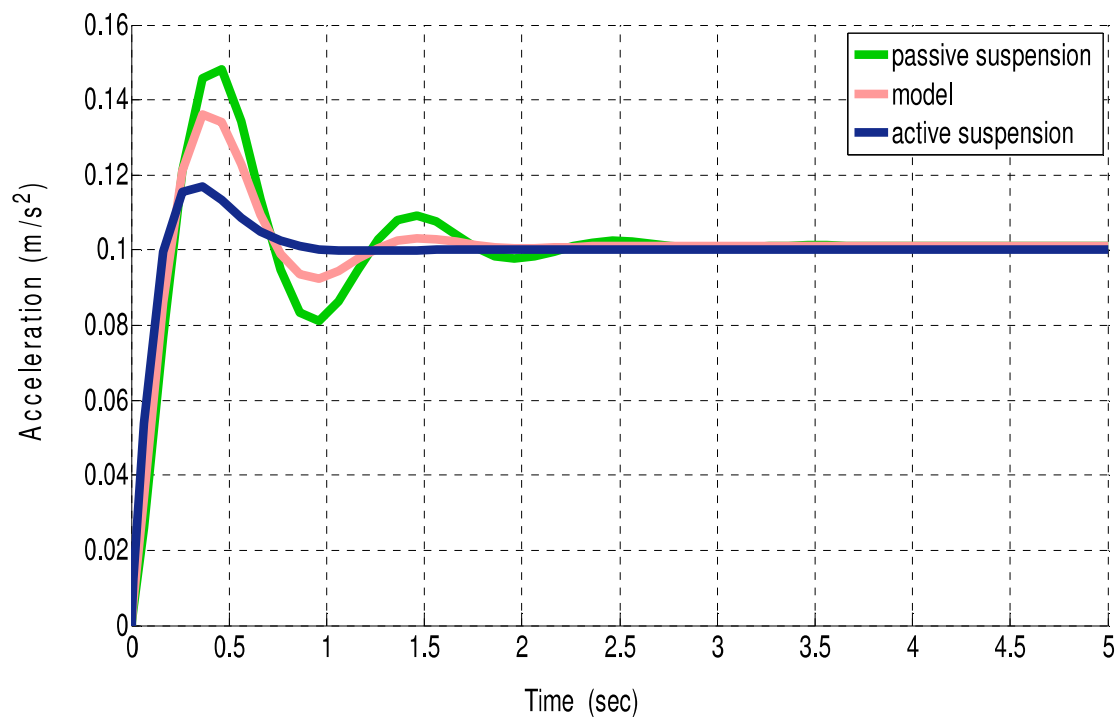

Figure III.12.a Acceleration

In the figure shows clearly that the acceleration of the body of vehicle much lower than passive suspension and sky hook model of reference because the amplitude of acceleration of the body of vehicle of active suspension less than amplitude of acceleration of the body of vehicle of other systems .

III 5.5.2 Deflection of wheel

Figure II.12.b gives us a comparison, the deflection of the wheel between the passive suspension and the active suspension with the sky-hook model of reference .

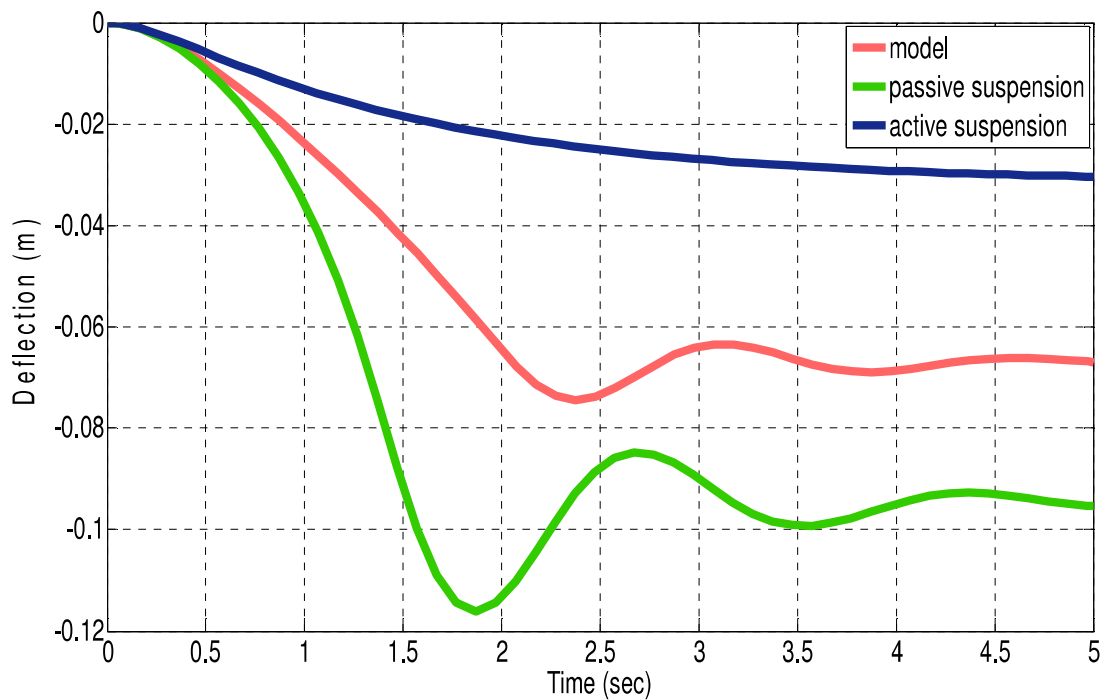

Figure III.12.b Deflection

In the figure shows clearly that the deflection of wheel of active suspension much lower than passive suspension and sky hook model of reference which means the active suspension reduce the vibration .

III 5.5.3 Control force

Figure III.12.c. represented the control force applied of the active suspension for following profits $GE=10$, $GC=1$, $GU=300$.

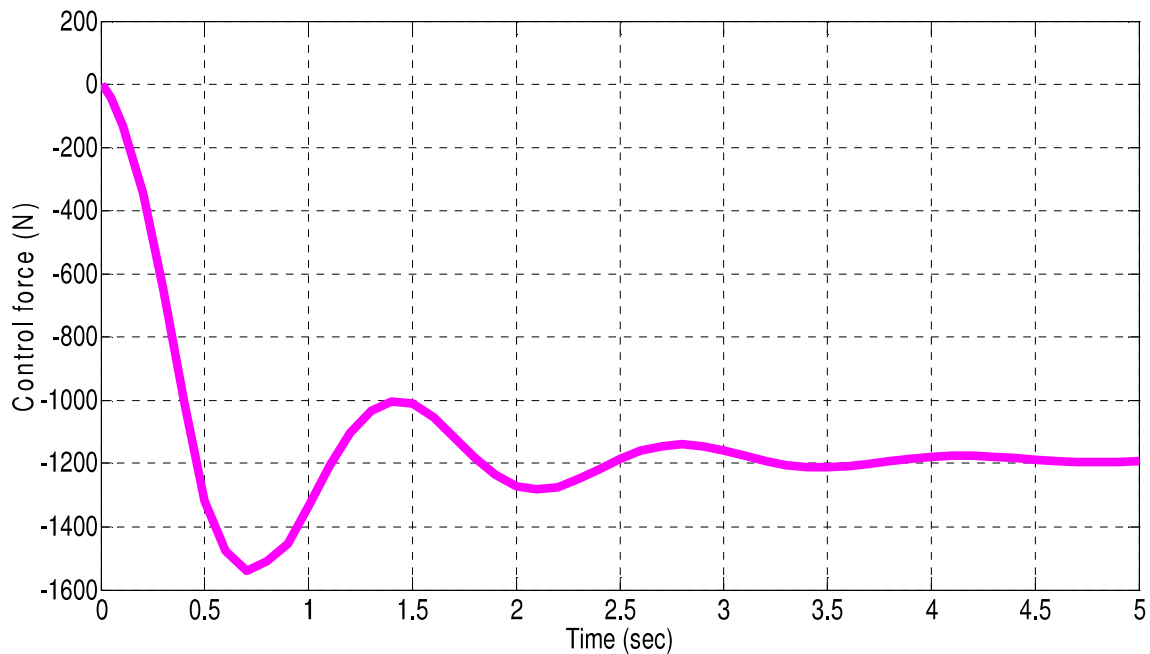

Figure III.12.c Control force

The maximum value of amplitude of the control force is in the opposite direction of the motion 100 N, so the active suspension system has good performance because control force using feedback to improve system response.

we clearly see that the active suspension gives a better result than the passive suspension which means that an actuator force to an active suspension reduce the vibration which result in improving the security and the comfort for passenger.

Conclusion

In this chapter we saw the application of the regulation by fuzzy logic in the controlling of our system of active suspension. This approach offers compared to the classical methods a good amount of advantages:

- Simple design.
- Flexibility of its application and its good adaptation to the various systems of regulation.
- Does not require a knowledge of the mathematical model of the system has to control.

However, the choice of the parameters of the regulator (universe of the discourses , functions of memberships...) remain a very difficult task and the development of the base of the rules is not always easy to formulate in linguistic rules. It is hard, because it depends much on human expert testimony.

General conclusion

The methodology was developed to design an active suspension for a passenger vehicle by designing a controller, which improves performance of the system with respect to design goals compared to passive suspension system. Mathematical modeling has been performed using a degree of freedom model of the quarter vehicle model for passive and active suspension system considering only pump motion to evaluate the performance of suspension with respect to various contradicting design goals.

Fuzzy logic controller design approach has been examined for the active system suspension travel in active case has been found reduced. By including an active element in the suspension, it is possible to reach a better compromise than is possible using purely passive elements. The potential for improved ride comfort and better road handling using fuzzy logic controller design is examined. The objectives of this project have been achieved. Dynamic model for linear quarter vehicle suspensions systems has been formulated and derived only one type of controller is used to test the systems performance which is fuzzy logic controller .

Bibliography

- [1] **Pinhas. Barak**, Design and Evaluation of Adjustable automobile Suspension. SAE Journal PP 114-130, 1989.
- [2] **J.Chajette**, Technique automobile, 2. le châssis, BORDAS, Paris, 1977, Dunod.
- [3] **Boukerrie brahime, Ladjal Kamel**, Application de la logique floue et des réseaux neuro-flous à la commande des suspensions semi actives des véhicules, PFE, IGM, USTHB, 2000.
- [4] **M.Benferhat, A.Benhabib**, Etude comparative des performance de suspension passive, active, semi-active applique au quart de véhicule, PFE, IGM, USTHB, 1997.
- [5] **Louis Jézéquel**, Active control in Mechanical Engineering, International Symposium MV2; Hermès paris, 1995.
- [6] **Claude Foulard**, Identification et commande des systèmes.
- [7] **C.yue, T.Butsuen, J.K.Hedricck**, Alternative Control Lows for Automotive Active Suspensions, Journal of Dynamic Systems, Measurement, and Control; JUNE 1989, Vol.111/291.
- [8] **Hansruedi Bühler**, Réglage par logique floue, 1994 Presses Polytechniques et universitaires Romandes, CH-1015 Lausanne.
- [9] **M.V.C.Rao and V.Prahlad**, A tunable fuzzy logic controller for vehicle active suspension systems, Fuzzy sets and systems 85(1997) 11_21, 1997 Elsevier science B.V.
- [10] A project report submitted in partial fulfillment of the requirements for the award of the degree of Master of Engineering (Electrical – Mechatronics and Automatic Control). Faculty of Electrical of Engineering University Teknologi Malaysia MAY 2008
- [11] **KHOUKHI Mohamed amine**, controle par logique floue du system de freinage ABS, USTHB, 2014.

- [12] FATTIH Moussa, SAHRAOUI Mohamed , Performances des Schémas de Contrôle d'une Suspension Semi Active, **Intégrant la Dynamique Interne de Bouc Wen, d'un Amortisseur Magnéto-Rhéologique (MR).** *USYHB* ,2010.
- [13] <http://eprints.utm.my/26881/3/ElnazAkhbariMFKE2010CHAP1.pdf>
- [14] BENRAS Mohamed-Lamine & BELKALOUL Amine, **Contrôle par logique floue d'une suspension semi-active à amortisseur Magnéto-Rhéologique,** *USYHB* ,2007.
- [15] A Study of **Membership** Functions on Mamdani Type Fuzzy Inference System for Industrial Decision-Making Chonghua Wang Lehigh University, 2005.
- [16] *Dr. Qadri Hamarsheh* Neural Network and fuzzy logic (360514)
- [17] **Messahel Abed EL Halime, Nssane Merzouk,** Application de la logique floue à la commande des suspensions actives des véhicules, PFE, IGM, USTHB, 1999.
- [18] **F.Titel, K.Belarbi,** Conception de contrôleur à logique floue par les algorithmes génétiques, Magister, Institut d'électronique, Université Ferhat Abbas ,Sétif, 1997.
- [20] **Mitsuo Gen and Runwei Cheng,** Genetic algorithms and engineering design, Ashikaga, institute of technology , Ashikaga Japan,1997.
- [21] **D.Goldberg,** Genetic Algorithms in search, optimisation, and machine learning, Addison Wesley Publishing Company, Inc Princeton, 1998.
- [22] **K.Mesgouni,** Application des algorithmes génétiques à la commande des MAS- investigation dans le domaine de la commande adaptative, rapport de DEA en génie électrique ,Gegely Lyon , France
- [23] **Xiao Peng, V.Prahlad and computer engineering,** DNA coded GA for the rule Base Optimization of a Fuzzy Logic Controller,10 kent ridge crescent, Singapore 119260, Proceeding of the 2001 IEEE Congress of Evolutionary Computing Seoul, Korea.
- [24] **X.M. Qi,T.C.chin;** Genetic algorithms based fuzzy controller for high order systems, School of Electrical and Electronic Engineering, Nanyang Technological University, Nanyang Avenue, Singapore 639798, fuzzy set and systems 91 (1997) 279-284.
- [25] **International Journal of Advances in Engineering & Technology, Dec., 2015.** PID controller of active suspension system for a quarter car model PID .