

## Experimental research of diagnostic measurement tests for power transformers

A. Aibeche<sup>1</sup>, S. Grouni<sup>1,2</sup>, H. Akroum<sup>1</sup> and K. Boualegue<sup>3</sup>

<sup>1</sup> Laboratory of Applied Automation (LAA), FHC, University UMBB of Boumerdes, 35000, ALGERIA

<sup>2</sup> Departments of Electrical Engineering, FSI, University UMBB of Boumerdes, 35000, ALGERIA

\* Corresponding Author: Email: [nababd2001@yahoo.fr](mailto:nababd2001@yahoo.fr), [said.grouni@yahoo.com](mailto:said.grouni@yahoo.com) and [akroum@yahoo.fr](mailto:akroum@yahoo.fr)

### Abstract:

This paper deals with experimental research of practical diagnostics measurement tests in industrial power transformers. In practical research we analyze the quality insulation diagnostic. The transformers system insulation is evaluated by using diagnostics of the dissipation factor in data industrial transformer (250 MVA, 15.75/220 kV) application. The insulation quality of power transformer is determined by multiple measurement tests of the insulation resistance winding, capacitance and dielectric dissipation factor. The measurement tests of dissipation factor given at the end of the production cycle not only assures that the quality of the transformer meets the specified levels but also provides insight into the subtleties of the manufacturing process. This paper gives an experimental research of measurement tests setup of dielectric dissipation factor that used GST and Guard mode techniques of earthing systems transformers insulation.

**Keywords:** Diagnostic, Power Transformer, Insulation Resistance, Capacitance, Dissipation Factor.

### 1. Introduction

While operating principles of transformers remain the same, the challenges of maintaining and testing transformers have evolved along with transformer design and construction. Modern transformers are designed to closer tolerances than transformers in the past. Thus effective regular maintenance and testing is even more essential to continued operation when traditional “over design” cannot be relied on to overcome abnormal conditions.

The utility engineer must be familiar with all aspects of maintenance and testing and make use of state of the art tools and techniques for evaluating transformer condition. While on-line diagnostic systems and computerized testing methods are very helpful, they are not a substitute for sound engineering judgment and expertise.

Power Transformer is the significant equipment in power transmission and distribution systems due to its high price. Normally, the power transformer is designed to have a long operational life, which depends on its operation and maintenance.

Electrical properties of insulation change due to age conditions of operating and continuous stress. The main contributor to the breakdown of high voltage equipments is the insulation failure. Insulation in power transformer is tested by two methods:

1-Polarization Index (**PI**) of Insulation Resistance (**IR**)

2-Dielectric insulation factor test (**Tan delta**) measurement.

This paper deals with discussion of the dissipation factor measurements that can be carried out on the insulation of high power transformers during routine maintenance procedures. This presentation includes the outlines setup of measurements and calculations are presented of test results with summary conclusions.

### 2. Principal Physical parameters

#### 2.1. Insulation resistance

This test has been the most usual historically, being called to “megger” the transformer (the term comes from the firm of the first Megger systems).

This test is performed on a measuring tester able to generate high continuous voltages usually of 5000V that applied between both dielectric terminals of the power transformer (one terminal to all the bushings joined in high voltage, the other to low voltage and ground) allow evaluating the punctual dielectric status inside. The tester has a high voltage tester operating from batteries or from the main. Measuring principle is based in measuring current / voltage in a continuous way that evolves as an answer to a voltage step.

Insulation Resistance will be the quotient between voltage and current at the end of minute 1 of the test. This parameter should be above a minimum normalized value. It contains direct information from the dielectric system status in the transformer, but is very influenced by temperature (and should be temperature normalized / corrected). So, it's usual another parameter named Polarization Index (PI). To measure it, the test is extended from minute 1 to minute 10, being PI, the quotient of currents in both time instants. This value is now independent from temperature and should be comparable in consecutive tests.

$$IP = \frac{IR(1 \text{ min reading})}{IR(10 \text{ min reading})} = \frac{I_L(1 \text{ min})}{I_L(10 \text{ min})} \quad (1)$$

## 2.2. Capacitance and Dissipation Factor

Dissipation factor is defined as the ratio of the real power generated by losses in a dielectric divided by the total voltage applied to the dielectric times the magnitude of the current flowing through it.

Dissipation factor measurements are also called  $\tan(\delta)$  measurements in International Electro technical Commission (IEC) and other test standards. This is because the dissipation factor is numerically equal to the tangent of the angle ( $\delta$ ) between the current flowing through a dielectric and a quadrature current that would flow through a loss free capacitor (Fig.1).

Capacitance and Dissipation Factor are testing of electrical insulation has been embraced by many in the insulation field as it provides information on the dielectric constant of the insulating materials as well as the dielectric losses. The dielectric constant is an intrinsic material property that influences the capacitance between two electrodes at different potential. In turn, the capacitance influences the voltage gradient distribution within assembly

components. Uneven concentration of high voltage gradients in the insulation, typically measured in kV/mm, contributes to increased dielectric power loss where the gradient is higher. In turn, higher power loss heats the insulation. Localized hot spots may develop which start deteriorating the insulation that would eventually lead to dielectric failure. Power factor is particularly recommended for detecting moisture and other loss-producing contaminants in transformer windings and bushings.

## 2.3. Relationship between current capacitance and dissipation factor

In an ideal insulation system connected to an alternating voltage source, the capacitance current  $I_c$  and the voltage are in perfect quadrature with the current leading. In addition to the capacitance current, there appears in practice a loss current  $I_r$  in phase with the voltage as shown in Fig 1.

The current taken by an ideal insulation (no losses,  $I_r = 0$ ) is a pure capacitive current leading the voltage by  $90^\circ$  ( $\theta = 90^\circ$ ). In practice, no insulation is perfect but has a certain amount of loss and the total current  $I$  leads the voltage by a phase angle  $\theta$  ( $\theta < 90^\circ$ ). It is more convenient to use the dielectric-loss angle  $\delta$ , where  $\delta = (\theta - 90^\circ)$ . For low power factor insulation  $I_c$  and  $I$  are substantially of the same magnitude since the loss component  $I_r$  is very small.

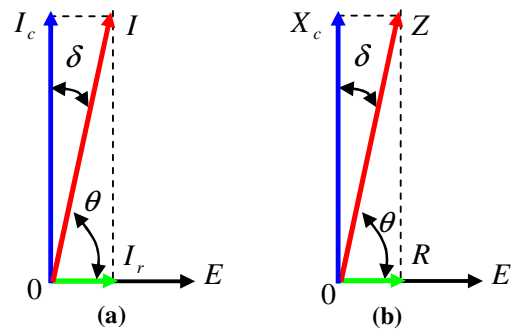

**Fig 1:** (a) Vector Diagram Insulation System  
(b) Vector Diagram Showing Resistance and Reactance

The expressions of power factor and dissipation factor and losses are defined as:

$$PF = \cos \theta = \sin \delta = \frac{I_r}{I} \quad (2)$$

$$DF = \cot \theta = \tan \delta = \frac{I_r}{I_c} \quad (3)$$

$$W_{loss} = E.I_r = E.I_c .tg \delta = E^2 .C .\omega .tg \delta \quad (4)$$

The important characteristic of capacitor is the ratio of its loss resistance to the reactance, which is the dissipation factor. This relationship is shown in the vector diagram (Fig 1).

In cases where angle  $\delta$  is very small,  $\sin \delta$  practically equals  $\tan \delta$ . For example, at power factor values less than 10 % the difference will be less than 0,5 % of reading while for power factor values less than 20 % the difference will be less than 2 % of reading.

The values of  $I_c$  will be within 99,5 % of the value  $I$  for power factor ( $\sin \delta$ ) values up to 10 % and within 98 % for power factor values up to 20 %.

If it is desired to find the value of the charging current  $I_c$  at a given test voltage and frequency, it may be determined from the following relationship:

$$I_c = V \omega C \quad (5)$$

In reality, a capacitor possesses both a series and parallel loss resistance as shown in Fig 2. The frequency of the applied voltage determines which loss dominates, however, at low frequencies (50/60 Hz) only the parallel losses  $R_p$ , predominately generated in the dielectric, are generally measured. For a particular frequency, any loss can be expressed in terms of either a series or parallel equivalent circuit with equal accuracy. The choice is a matter of convenience. The dissipation factor ( $\tan \delta$ ) for the series equivalent circuit is defined as:

$$\tan \delta = R_s \omega C_s \quad (6)$$

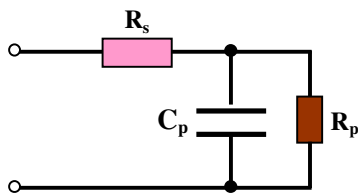

**Fig 2:** Equivalent Circuit for Capacitor Losses

The conversion formulas are presented by the equivalent parallel impedance  $C_p$  and  $R_p$  :

$$\tan \delta = \frac{1}{R_p \omega C_p} \quad (7)$$

$$C_p = \frac{C_s}{1 + \tan^2 \delta_s} = \frac{C_s}{1 + (R_s \omega C_s)^2} \quad (8)$$

$$R_p = R_s \left( 1 + \frac{1}{\tan^2 \delta_s} \right) = R_s \left( 1 + \frac{1}{(R_s \omega C_s)^2} \right) \quad (9)$$

### 3. Significance of Capacitance and dissipation Factor

A large percentage of electrical apparatus failures are due to a deteriorated condition of the insulation. Many of these failures can be anticipated by regular application of simple tests and with timely maintenance indicated by the tests. An insulation system or apparatus should not be condemned until it has been completely isolated, cleaned, or serviced and measurements compensated for temperature. The correct interpretation of capacitance and dissipation factor tests generally requires knowledge of the apparatus construction and the characteristics of the particular types of insulation used.

Change in the normal capacitance of an insulation indicate such abnormal conditions as presence of a moisture layer, short circuit, or open circuits in the capacitance network. Dissipation factor measurements indicate the following conditions in the insulation of a wide range of electrical apparatus:

- Chemical deterioration due to time and temperature, including certain cases of acute deterioration caused by localized overheating.
- Contamination by water, carbon deposits, bad oil, dirt and other chemicals.
- Severe leakage through cracks and over surfaces.
- Ionization.

The interpretation of measurement is usually based on experience, recommendation of the manufacturer of the equipment being tested, and by observing these differences:

- Between measurements on the same unit after successive intervals of time.
- Between measurements on duplicate units or a similar part of one unit, tested under the same conditions around the same time, e.g., several identical transformers or one winding of a three-phase transformer tested separately.
- Between measurements made at different test voltages on one part of a unit; an increase in slope (tip-up) of a dissipation factor versus

voltage curve at a given voltage is an indication of ionization commencing at that voltage.

An increase of dissipation factor above a typical value may indicate conditions such as those given in the previous paragraph, any of which may be general or localized in character. If the dissipation factor varies significantly with voltage down to some voltage below which it is substantially constant, then ionization is indicated. If this extinction voltage is below the operating level, then ionization may progress in operation with consequent deterioration.

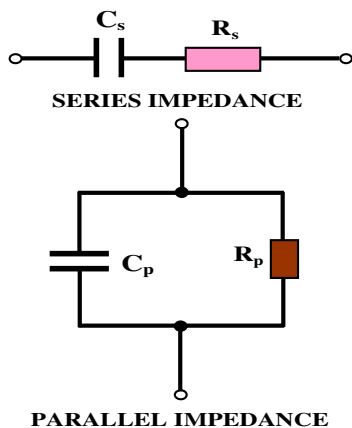

Fig 3: Series-Parallel Equivalent Circuit

Table 1: CRRECTION FACTOR AS PER IEEE C57.12.90

Test Temperature (°C)	Correction Factor K2
10	0,80
15	0,90
20	1,00
25	1,12
30	1,25
35	1,40
40	1,55
45	1,75
50	1,95
55	2,18
60	2,42
65	2,70
70	3,00

Some increase of capacitance (increase in charging current) may also be observed above the extinction voltage because of the short circuiting of numerous voids by the ionization process.

An increase of dissipation factor accompanied by a marked increase in capacitance usually indicates excessive moisture in the insulation. Increase of dissipation factor alone may be caused by thermal deterioration or by contamination other than water. Unless bushing and pothead surfaces, terminal boards, etc., are clean and dry. Measured quantities may not necessarily apply to the volume of the insulation under test. Any leakage over terminal surface may add to the losses of the insulation it self and may, if excessive, give a false indication of its condition.

#### 4. Setup and Procedures tests

##### 4.1. Insulation resistance testing

The following 3 tests and corresponding wiring diagrams will completely test a three phase transformer. Allow at least 1 minute (or 10 minutes) for each test or until the reading stabilizes. Can be tested as follows:

**Test 1:** H.V windings & Earthed metalwork – One test checks all – as winding are internally connected:

**Test 2:** L.V windings & Earthed metalwork – One test checks all –

NOTE: There may be link on the transformer from NEUTRAL to EARTH,

This will have to be removed prior to carrying out the Insulation Test.

**Test 3:** Between H.V windings & L.V windings.

##### 4.2. Dissipation factor test use Schering Bridge

Dissipation factor is usually determined by a bridge measuring technique, such as the Schering Bridge or transformer ratio Arm Bridge, use DELTA 2000, which includes power source, standard capacitor and balancing bridge.

Tan Delta test is conducted at 10 kV, 50 Hz AC voltage. It is combined capacitance & dissipation factor (Tan delta) bridge.

Generally Tan delta measured in three modes as given below:

**Mode 1:** Ungrounded specimen test (UST).

**Mode 2:** Grounded specimen test (GST) &

**Mode 3:** Guard mode

Connections are shown in Fig 7.

## 5. Results and Discussions

The tan delta Dissipation factor test conducted as per clause No. 10.10.3 in ANSI C 57 12.90.

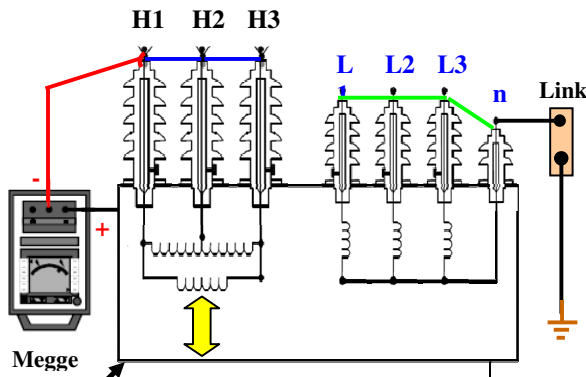

**Fig 4:** High voltage winding to low voltage winding and ground (test 1).

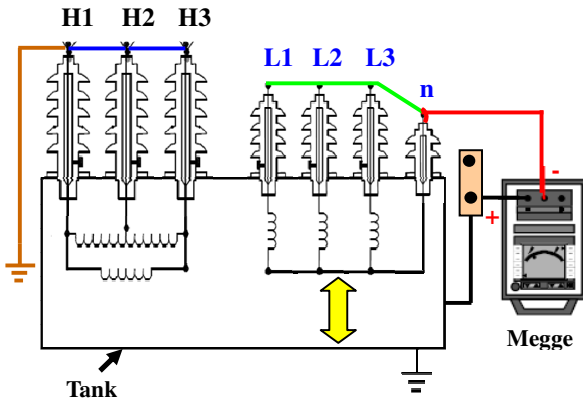

**Fig 5:** Low voltage winding to high voltage winding and ground (test 2).

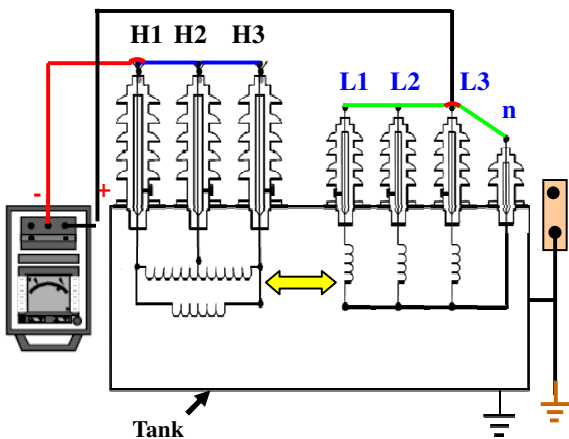

**Fig 6:** High voltage winding to low voltage winding (test 3).

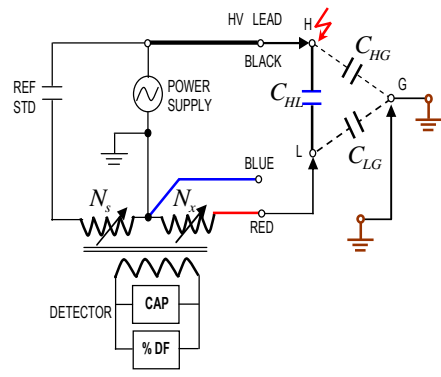

**Fig: (a)**

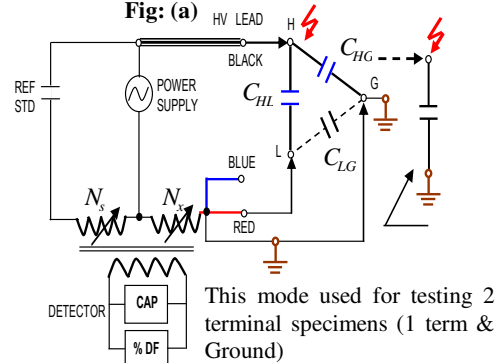

**Fig: (b)**

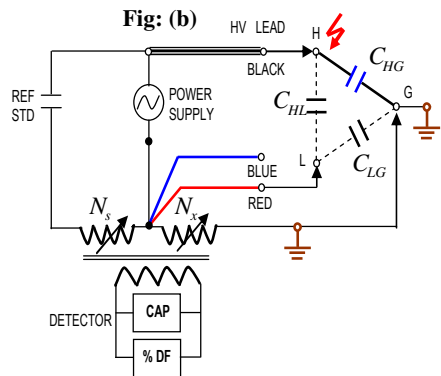

**Fig: (c)**

**Fig 7:** Simplified measuring circuit diagram (Two-Winding Transformer Tests).

- (a) **UST:** MEASURES RED, GROUNDS BLUE
- (b) **GST GROUND:** GROUNDS RED & BLUE
- (c) **GST:** GUARDS RED & BLUE

DF is very sensitive to temperature. DF (Tan delta) values do not change with applied voltage. The reference temperature commonly used is 20 degree centigrade; average oil temperature & ambient temperature are recorded while testing.

In case of oil filled transformer & reactors tan delta should not exceed 0,5 % at 20°C. Values of Correction Factor K are listed below in Table 1.

TRANSFORMER TEST REPORT			
250 MVA, 15,75/220 kV two winding transformer			
DATE 12/04/2010			
MEASUREMENT OF INSULATION RESISTANCE WINDING			
Top Oil Temp :	29.2°C		
COMBINATION	10 sec	60 sec	600 sec
HV/Earth	416 MΩ	620 MΩ	930 MΩ
LV/Earth	224 MΩ	356 MΩ	560 MΩ
HV/LV	525 MΩ	805 MΩ	1160 MΩ
OIL TESTS			
Break-down voltage	75 kV		
Moisture content	13 PPM		
Tan Delta	0,0044		
Resistivity at 90°C	200*10 <sup>12</sup>		

Table (1): data measurement insulation resistance

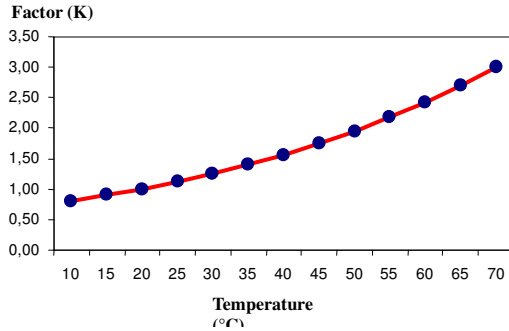

Fig 14: Correction Factor (Tan Delta)

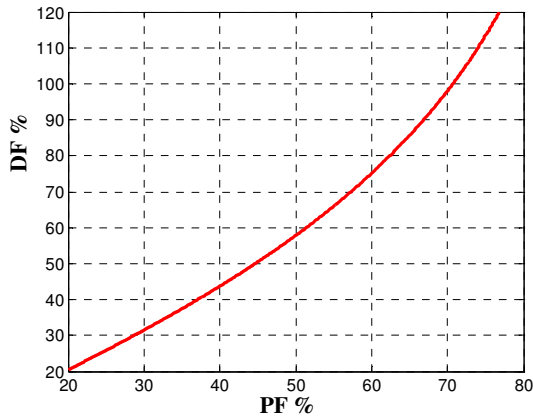
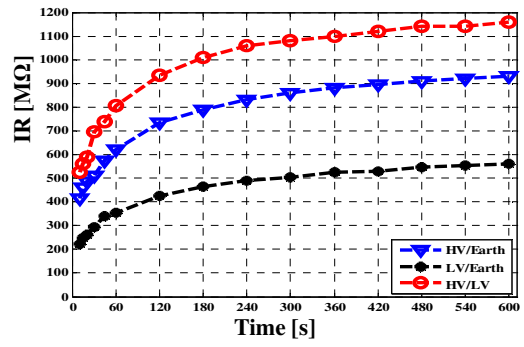
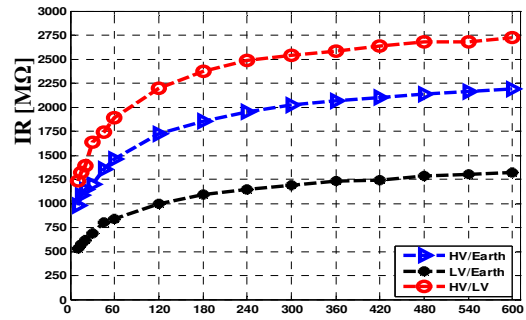

Fig 15: Graph for converting power factor vs. dissipation factor above 20%



(a)



(b)

Fig.15: curves of variation insulation resistance

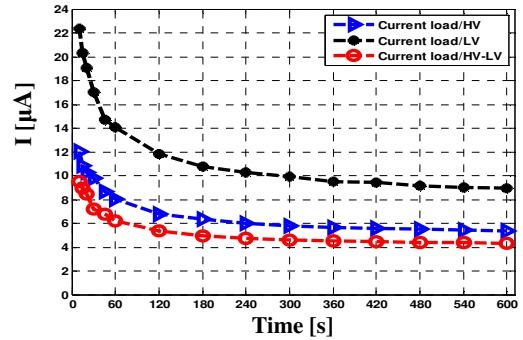

(a)

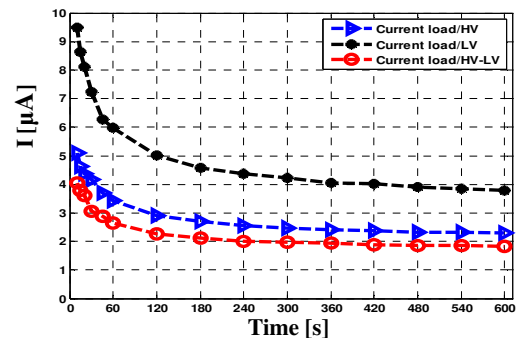

(b)

Fig .16: curves of variation current dissipation.

Test N°	Insulator tested	Combination	Mode of Test	Capacitance [PF]	Current I[mA]	$W_{loss}$ [watts]	DF% in 70°C	Correction DF% In 20°C	OK NOT OK
<b>Inject in HV, Measure LV</b>									
1	$C_{HG+C_{HL}}$	HV/LV+Earth	GST GND	16643,00	52,24	3,66	0,70	0,23	OK
2	$C_{HG}$	HV/LV+Guard	GST	6601,80	20,75	2,63	1,27	0,50	NOT OK
3	$C_{HL}$	HV/LV	UST	10035,00	31,50	0,66	0,21	0,07	OK
<b>Inject in LV, Measure HV</b>									
4	$C_{LG+C_{HL}}$	LV/HV+Earth	GST GND	29596,00	92,91	7,78	0,84	0,28	OK
5	$C_{LG}$	LV/HV+Guard	GST	19559,00	61,40	7,20	1,17	0,39	OK
6	$C_{HL}$	LV/HV	UST	10034,00	31,50	0,67	0,21	0,07	OK
<b>After Rectification of Fault of selector</b>									
<b>Inject in HV, Measure LV</b>									
1	$C_{HG+C_{HL}}$	HV/LV+Earth	GST GND	16643,90	52,26	3,65	0,60	0,46	OK
2	$C_{HG}$	HV/LV+Guard	GST	6602,70	20,79	2,60	0,62	0,48	OK
3	$C_{HL}$	HV/LV	UST	10035,90	31,52	0,65	0,51	0,39	OK
<b>Inject in LV, Measure HV</b>									
4	$C_{LG+C_{HL}}$	LV/HV+Earth	GST GND	29600,00	92,93	7,77	0,64	0,49	OK
5	$C_{LG}$	LV/HV+Guard	GST	19559,50	61,42	7,19	0,37	0,28	OK
6	$C_{HL}$	LV/HV	UST	10034,90	31,52	0,66	0,52	0,40	OK

**Table (2) experimental setup of multiple test values**

Many of these failures can be anticipated by regular application of simple tests and with timely maintenance indicated by the tests. An insulation system or apparatus should not be condemned until it has been completely isolated, cleaned, or serviced and measurements compensated for temperature. The correct interpretation of capacitance and dissipation factor tests generally requires knowledge of the apparatus construction and the characteristics of the particular types of insulation used.

Transformers have been used at power plants since the inception of alternating-current generation, a century ago. While operating principles of transformers remain the same, the challenges of maintaining and testing transformers have evolved along with transformer design and construction. Modern transformers are designed to closer tolerances than transformers in the past. Thus, effective, regular maintenance and testing is even

more essential to continued operation when traditional “over design” cannot be relied on to overcome abnormal conditions. The utility engineer must be familiar with all aspects of maintenance and testing and make use of state-of-the-art tools and techniques for evaluating transformer condition. While on-line diagnostic systems and computerized testing methods are very helpful, they are not a substitute for sound engineering judgment and expertise.

## 6. Conclusions

This paper has presented an experimental research of diagnosis measurement tests method for power transformers in industry. The insulation quality of electrical power transformer is tested for systems performance and reliability of dielectric absorption is confirmed by the experimental results through. In real world, the insulation degradation cannot be eliminated but minimized to give an appropriate

corrective action taken in immediate time. The practical results show that the method can effectively minimize equipment deterioration.

## References

1. Rao, S., 1991, *Power Transformer and special Transformers, New Delhi, Second Edition.*
2. Cooper, J. H., 2000, Field measurements of transmission cable dissipation, HV Testing, Monitoring and Diagnostics workshop, Virginia, pp.1.1-1.5.
3. Iwanusiw, Oleh W., 1985, The development of an automatic power factor test set for electrical insulation, Multi-Amp, Canada limited, Ontario, CANADA.
4. Singh, S., 2008, Comparative study on fault diagnosis on power transformers. Proc. of the Int. Conf. TRAFOSEM, ITMA, New Delhi.
5. Singh, S., 2008, New trends on power transformer fault diagnosis, Proc. of the Nat. Conf. on Recent Advances, in Elect. Engineering NIT Hamirpur.
6. R. B., Cinch, M., Hassig, J., Fuhr, T., Aschwanden, 2000, Assessment of insulation condition of large power transformer by on site electrical diagnostic methods, IEEE, Int. Sym on Elec. Ins., Anaheim CA, pp.13-16.
7. M., Hanif, 2005, Principles and applications of insulation testing with DC, IEP-SAC journal, ABB Electrical Industries Co Ltd, pp.53-63.