

Reliability of an Unstable Pipeline Used for Natural Gas Transportation

N. Abdelbaki, E. Bouali, R. Bouzid and M. Gaceb

Laboratoire de Fiabilité des Equipements Pétroliers et Matériaux,

Faculté des Hydrocarbures et de la Chimie, Université M'Hamed BOUGARA, Boumerdès, Algérie

Abstract: The various sections of a pipeline used for hydrocarbons transportation over great distances cross several different natural obstacles, amongst which one can name water saturated swampy grounds. The practice shows that the pipeline sections which are laid down on such grounds are submitted to a process of destabilisation in the direction of their principal axis. Under the action of several factors these sections change continuously their position with respect to their initial position which affects their reliability and can even lead to their rupture with disastrous consequences. The working reliability of the pipeline sections is given by their geometrical characteristics and their stress states. The latter vary with the positions occupied by the principal axis of the pipeline section in space, the longitudinal efforts in the wall of the pipes, the temperatures of the pipe and the ambient medium, the internal pressure, the physic-mechanical soil characteristics and their distribution along the principal axis of the pipeline under consideration. In order to formulate the problem of the reliability of the pipeline sections laid down in water saturated grounds we use in this work the renewal theory and we assimilate each pipeline section into a system with a variable working regime. At the end of the study we give an application to a concrete case.

Key words: Hydrocabone transportation, pipeline, natural gas transportation

INTRODUCTION

The construction of pipelines in swampy zones carries enormous difficulties and necessitates the use of specific technological schemas, as well as special construction techniques. Once the pipeline achieved, it is important to follow its behaviour in exploitation. The state of a pipeline is determined by a number of parameters such as the geometric position in space of the principal axis of the pipes, the temperatures of the pipes' walls and of the ambient surrounding, the internal pressure, the external efforts applied on the pipes' walls, the physic-mechanical characteristics of the soils and their distribution along the principal axis of the pipeline.

During the exploitation, the pipeline works in a non stabilized regime and some regimes lead to a critical state and even to the rupture of the pipeline. Such cases are observed in sections of pipelines laid down on swampy soils. There is actually no general theory which answers all the questions associated to instabilities of work regimes of walls of pipelines laid down on such soils. Thus for the study of the impact of such instabilities on the functioning aptitude of the pipelines, the reliability methods are found to be fruitful. In effect, the coupling of approaches based on the systems reliability theory and

the methods of reliability analysis of mechanical structures permit to take into account the uncertainty during the conception, the verification and the maintenance of the constructions. When a new event takes place, it permits to evaluate the previsional reliability in terms of this event, which must therefore be included in the reliability analysis. Finally the study is ended by an optimisation procedure where are introduced the cost relative to the different measures to be taken at the construction stage of the pipeline and the possible actions during exploitation so that to maintain an optimal level of working safety of the pipeline.

CASE OF NOT BURIED PIPELINE SECTIONS LAID WITH ANCHORAGE

Particularities of the work regimes of pipelines laid down in swampy zones: These particularities are characterized by the low strength of the soil and by the movements of the pipeline, which permits important longitudinal and transversal displacements of the pipes, giving rise to very high flexion stresses in the pipe walls. These stresses can go beyond the bearing capacity limits of the pipes and thus leads to the rupture of the section. The stability of the pipelines in this case necessitates the application of

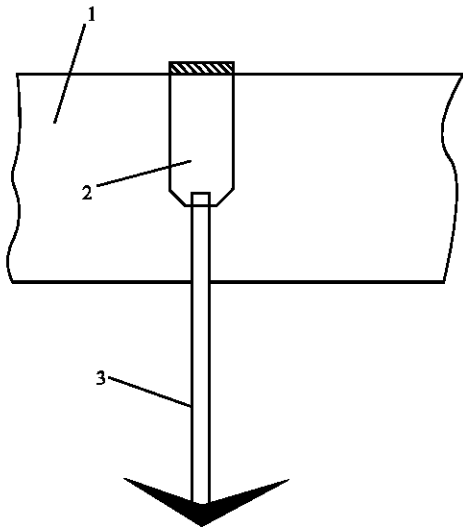

Fig. 1: Anchorage of the pipeline. 1-Pipeline
2-Anchorage collar 3-Anchorage stem

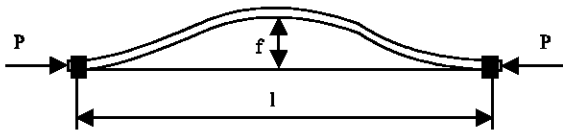

Fig. 2: Local bending of the pipeline between two anchorages

external concentrated or distributed load on the border of a small area of the lateral surface of some pipes of the sections. In other words, we use the reinforcements by anchoring for the pipelines sections laid down on swampy soils Fig. 1. Thus a section of a pipeline reinforced by anchorages disposed sufficiently far from one another is assimilable to an elastic bar Fig. 2 where the deflection f is a function of the dimensions of the section and the local bending of the pipeline.

Definition of the working regimes of the pipes walls: A pipeline section laid down on a swampy ground is subjected to extra loads which are function of the ordinary value of the deflection Fig. 2. We choose as a reference an extra top load defined by a given value of the deflection designated by f_{top} . Two possible cases arise:

- Either $f < f_{top}$ and in this study the overload has little effect on the rupture possibility of the section.
- Or $f = f_{top}$ and in this case the extra overload is one of the dominant factors which affect the rupture probability of the section.

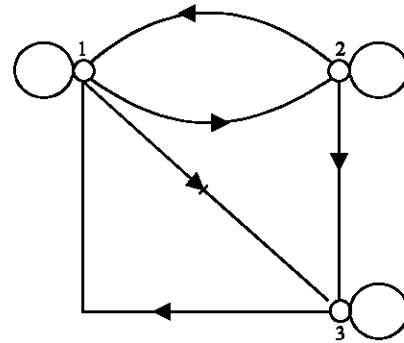

Fig. 3: Transition graph for a section laid on a swampy ground

The first study ($f < f_{top}$) defines the first work regime S_1 of the pipe walls and the second case ($f \geq f_{top}$) their second work regime S_2 . The non availability regime of the section due to repairing is designated S_3 .

Description of the mechanical model: The definition of the stochastic reliability model of the section in question is necessary to determine f_{top} for given concrete conditions of conception and exploitation. This model contains the transient input variables of the problem. The performance function $G(x)$ depends on the achievements of the transient variables $\{X\}$ amongst which some are function of the deflection f . This function emanates from the failure criterion defined by the exceeding of the equivalent stress σ_{eq} in the dangerous sections of the section, the pipes rupture limit being R_T , the failure probability is then defined by Melchers^[1].

$$P_f = \text{Prob}\{G(\{X\}) \leq 0\} \quad (1)$$

By analysing the mechanical reliability of the section for concrete conditions of construction and exploitation and basing on the model (1), the value of the deflection f is determined by strength of materials and soil mechanics calculations^[2,3].

Fiabilo-systemic approach: The section under study is assimilated to a multi work regime system^[4,5]. The transition graph from one regime to another is shown in Fig. 3. The working duration $\{\tau_1\}$ and $\{\tau_2\}$ under regimes S_1 and S_2 respectively are transient variables, of distribution functions $F_1(\tau_1)$ and $F_2(\tau_2)$. The good working times between failures ξ_1 and ξ_2 under regimes S_1 and S_2 obey exponential distribution laws of parameters λ_1 and λ_2 , respectively.

It is evident, that transition from the regime S_1 to the regime S_2 is only possible for $\tau_1 < \xi_1$ and this corresponds to a transition probability q_{12} given by the expression^[6].

$$\begin{aligned}
 q_{12} &= \text{Prob}\{\tau_1 < \xi_1\} \\
 &= \lambda_1 \int_0^{\infty} e^{-\lambda_1 t} F_1(t) dt = \lambda_1 \mathfrak{S}[F_1(t)]_{S=\lambda_1} \quad (2) \\
 &= \lambda_1 F_2^*(\lambda_1)
 \end{aligned}$$

Similarly, the transition from the regime S_2 to the regime S_1 is only possible after restoration of the pipeline and by analogy to the preceding case we have:

$$q_{21} = \text{Prob}\{\tau_2 < \xi_2\} = \lambda_2 F_2^*(\lambda_2) \quad (3)$$

The other pipeline state transition probabilities are:

$$q_{13} = 1 - q_{12}, q_{23} = 1 - q_{21}, q_{33} = 1 \quad (4)$$

For a given time interval t , the transition probabilities are given by the expressions:

$$Q_{12}(t) = \int_0^t e^{-\lambda_1 u} dF_1(u), Q_{21}(t) = \int_0^t e^{-\lambda_2 u} dF_2(u) \quad (5)$$

The dwelling times in states S_1 and S_2 designated by variables whose distribution functions are:

$$\begin{aligned}
 F_{\theta_1}(t) &= 1 - e^{-\lambda_1 t} [1 - F_1(t)] \quad (6) \\
 F_{\theta_2}(t) &= 1 - e^{-\lambda_2 t} [1 - F_2(t)]
 \end{aligned}$$

And whose average values are given by the following expression:

$$\begin{aligned}
 M\theta_1 &= \int_0^{\infty} e^{-\lambda_1 t} [1 - F_1(t)] dt = \frac{1}{\lambda_1} - F_1^*(\lambda_1) \quad (7) \\
 M\theta_2 &= \frac{1}{\lambda_2} - F_2^*(\lambda_2)
 \end{aligned}$$

On another hand, we distinguish the good working time $M\theta_1$, under the condition that at the initial moment, the section was in state S_1 and the average good working $M\theta_2$ time under the condition that at the initial moment, the section was in state S_2 . These two values can be determined from the following system of equations:

$$\begin{cases} M\theta_1 = M\theta_1 + q_{12} M\theta_2 \\ M\theta_2 = M\theta_2 + q_{21} M\theta_1 \end{cases} \quad (8)$$

Just after the repairing and the putting into service, the section under consideration reverts to regime S_1 and the average time between failures is given by the expression:

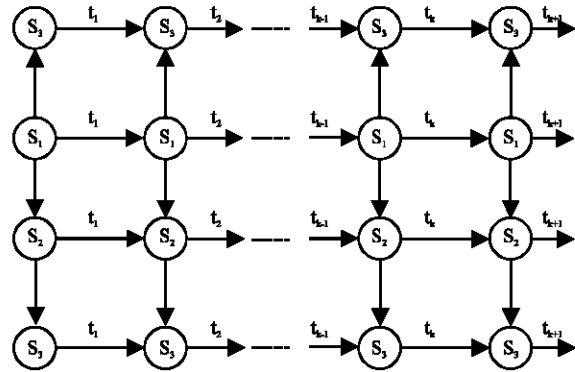

Fig. 4: Graph of the possible state transitions of a pipeline section laid down in swampy ground

$$M\theta_1 = \frac{M\theta_1 + q_{12} M\theta_2}{1 - q_{12} q_{21}} \quad (9)$$

Reliability control during exploitation: The reliability control aims at predicting the possible transition probabilities of the state of a pipeline section during exploitation. The results of such a control constitute a base for decision making on the technical measures to be taken to insure the required working surety level of the pipeline. A description of the methodology specific to the problem under consideration is given below. It consists in dividing the service duration envisaged T into k intervals so that the pipeline section being at the beginning of interval t_i at state S_1 , will at the end of this interval pass directly into one of the n possible intervals S_j . The model of possible transitions from one state to another, for a duration T is shown graphically in Fig. 4. The arrows indicate the possible state changes of a pipeline section.

Letting $Q_{ij}(k)$ be the possibility of transition during time t_k from state S_i to state S_j , the transition probabilities from one state to another are therefore:

$Q_{i0}(t_k), \dots, Q_{in}(t_k)$ satisfy the condition:

$$\sum_{j=0}^n Q_{ij}(t_k) = 1$$

The probability of transition from state S_i to state S_j during a period of time T is predictable by expression:

$$Q_{ij}(T) = 1 - \prod_{k=1}^N [1 - Q_{ij}(t_k)] \quad (10)$$

For a constant intensity of the probabilities distributions, expression (10) takes the form:

$$Q_{ij}(T) = 1 - [1 - q_{ij}]^N \quad (11)$$

Considering the possible state changes of the considered pipeline section over all the intervals and taking the last of the N considered states, that which corresponds to state S₂ and using the fundamental theorems of the theory of probabilities, the following expression is obtained for the prediction of the reliability of a pipeline section at the end of period T :

$$P_R = 1 - q_{12} (1 - q_{23})^{N-1} \sum_{k=0}^{N-1} \left(\frac{1 - q_{12} - 2q_{13}}{1 - q_{23}} \right)^k \quad (12)$$

Case of buried pipeline sections: The reliability of the pipes of buried pipelines is determined by the stress state in their walls, which vary as a function of the internal pressure, the pipe walls temperature, the bending of the pipeline sections and the variation of the physic-mechanical characteristics of the soil on which the pipeline is laid down. The relationship between the stress state in the pipes and these parameters are so important that even a given variation of only one parameter leads to the change of the stress state in the pipes walls. This may lead to a critical level of reliability and even to rupture of the pipes with disastrous consequences. The soils physic-mechanical characteristics vary generally along the line of the pipeline; if the pipeline sections are laid down on soils with little deformability they occupy practically a stable position in the vertical plane. The displacement of sections of the pipeline laid down on weak soils leads to the bending of pipeline and certain sections of the pipes become the weak segment of the pipeline. In soil mechanics the downward displacement in the vertical plane, is known as the compacting. The collapse of the soil carrying section of a pipeline takes place generally progressively and may sometimes take decades^[7]. The following question is then put forward: how does the non stabilized state of the compacting influence the reliability of the pipeline? The maintaining of the pipelines failure risk at a very weak level obliges to pay a particular attention to variability of the pipes and soils characteristics. The search for a procedure allowing bringing about a diagnostic on the keeping of the security level of the pipeline is more than necessary and is the object of this communication.

The phenomenon of the non-stabilized compacting of the soils: When a load is applied, we observe an initial soil compaction under the effect of the increase in the effective stress tensors. Then, the compaction will evolve in time and reaches its final value when the interstitial overpressure has totally vanished^[8]. The process of formation of the non-stabilized compactings or the

process of variation of their magnitudes with time under the action of the loads is a non-stationary process. The load of the pipes applied to a water saturated soil is supported at the moment of the laying down partly by the solid phase and partly by the liquid phase whose pressure increases. This results in a water movement which does not stop until all the excess water has been dissipated and the pressure has dropped back to its initial hydrostatic value. The passage from the non drained state to the drained state needs a delay related to the water flow speed through the soil^[9]. The determination of the compaction under the effect of load necessitates, in principle, the knowledge of the mechanical properties of the soils through their behaviour law. Unfortunately, this law of behaviour is generally not known. There exist some simulation methods, the indirect methods, where we assume an approximate behaviour law. The most interesting methods when we content ourselves with the knowledge of the behaviour along a path are the oedometric and the tri axial methods^[10].

Description of the mechanical model: The loads S and the strength R of the pipe materials are determined by a set of perturbation factors. Their distributions are considered to be normal and have average values \bar{R} and \bar{S} , of standard deviation σ_R and σ_S . The expression (1) of the failure probability P_f is thus equal to the event occurrence probability (R<S)^[11], i.e.:

$$P_f = \{R < S\} = \frac{1}{2} - \Phi \left[\frac{\bar{\eta}_{0,2} - 1}{\frac{1}{\theta} (V_R \bar{\eta}_{0,2})^2 + V_S} \right] \quad (13)$$

Where: $\theta = \frac{\bar{R}_{0,2}}{R}, \bar{\eta}_{0,2} = \frac{\bar{R}_{0,2}}{S}, V_R = \frac{\sigma_R}{R}, V_S = \frac{\sigma_S}{R}$

The mathematical expectation of the pipes rupture limit \bar{R}^t is determined by that of specimens taken from the pipe steel, by expression^[12]:

$$\bar{R}^t = \bar{R} k_e k_h$$

Where: k_e, k_h are the scale and homogeneity coefficients.

Te failure probability of a pipe is given by the expression^[13]:

$$P_f^t = 1 - [1 - P_f]^{V_t/V_e}$$

Where: V_b, V_e are the pipe and specimen material volumes.

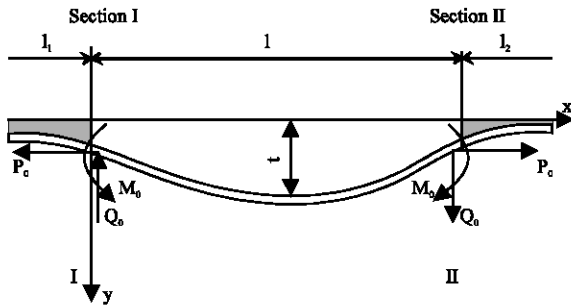

Fig. 5: Calculation scheme of a suspect pipeline section

The stress equivalent to the really applied stresses in the dangerous sections I-I and II-II Fig. 5 is determined by the Von Mises criterion^[12]. For the sake of the calculations the factors P_0 , Q , M_0 are determined in terms of the dimensions of the pipes, the pressure inside the pipes and the soils physic-mechanical characteristics according to the methodology described in^[2].

The suspect pipeline section I Fig. 5 is laid down on a soil with consistence indices B and dynamic viscosity η_D . The specific weight (weight per unit length) of the pipes q_i is considered to be greater than that of the soil q_s .

Depending on the soil consistence indices B , the compaction can take place due to the infiltration phenomenon ($B = 0,8$) or by pipe displacement in the soil ($B > 0,8$)^[7]. The soil compaction is a function $f = f(q_p, q_s, D, \eta_D, t)$ causing the bending of the section I (Fig. 5) which becomes subjected to traction under the action of the other sections of the pipeline I1 and I2. To each compaction value, correspond well determined values of the real stresses in the pipe walls and one value of the pipe failure probability.

Failure scenario: It is given by the expression $R_i - S_{eq}(P, Q, M_i) < 0$ and should be studied at the points of dangerous sections I and II.

- The first scenario $R_i - \max S_{eq} < 0$ in section I
- The second scenario $R_i - \max S_{eq} < 0$ in section II

This comes up to compose two scenarios in series.

Distribution density of times between failures: The apparition moments of new compactions of the soil carrying the suspect section of the pipeline, form an transient renewal flow. The renewal process, in this case, is characterized by the function of times until the detection of the first compaction judged grave $F_1(t)$, as well as by the time distribution function between the

ith and the (i+1)th dangerous compaction, of distribution densities $f_1(t)$ and $f(t)$, respectively. The failure probabilities P_f of the section I (Fig. 5) is function of the number of dangerous collapse events.

The distribution density of the times between failures of section I is in this case given by the expression^[5].

$$\omega_1(t) = \sum_{m=1}^{\infty} f_n(t) P_f P_R^{m-1} \quad (14)$$

Where $f_n(t)$ is the distribution density of the times until the manifestation of the nth dangerous compaction defined by the recurrence formulae :

$$f_{n-1}(t) = \int_0^t f_n(t-\tau) f(\tau) d\tau \quad (15)$$

The determination of the Laplace transform of the expression (14) is necessary to develop section (3.5) of this study, taking into account of the transforms:

$$\omega_1^*(\alpha) = \int_0^{\infty} e^{-\alpha t} \omega_1(t) dt, \quad f_1^*(\alpha) = \int_0^{\infty} e^{-\alpha t} f_1(t) dt, \quad f^*(\alpha) = \int_0^{\infty} e^{-\alpha t} f(t) dt$$

Then the transform of the expression (14) takes the form:

$$\omega_1^*(\alpha) = \sum_{m=1}^{\infty} f_1^*(\alpha) \cdot f^{*m-1}(\alpha) \cdot P_f \cdot P_R^{m-1}$$

This expression can be presented in the form:

$$\omega_1^*(\alpha) = \frac{f_1^*(\alpha)}{[1 - P_R f^*(\alpha)]} P_f \quad (16)$$

Risk based optimization procedure: In the case of the problem considered, the best decision is that which corresponds to the greatest mathematical expectation of economical usefulness and the risk associated consequences are measured in the results usefulness scale. The concept of usefulness permits to take the dispersion of results probability distribution into account, i.e. the risk. The investment cost can be represented by a probability distribution and it is rational to take into account the gain or usefulness expectation to evaluate the optimal decision. The values of the probability P_f associated with the pipe failure

consequences, are established according to a model including the uncertainty on the physic-mechanical properties of the pipe steels, on the pipe geometrical dimensions, on the physic-mechanical characteristics of the soils.

The possible results of an inspection of the compaction of a suspect section of the pipeline are transient variables which will lead to decision making. The best of the decisions consists of choosing a strategy which maximises the usefulness expectation which is expressed in our case as a function of the total cost CT of one kilometre of the pipeline^[14]:

$$C_T = C_0 + C_k + C_p + U \tag{17}$$

Where C_0 is the construction cost of one kilometre pipeline on a customary little deformable soil.

C_k is the cost of the special measures by kilometre length for the suspect section.

C_p is the loss due to the dead cost at C_k case where the measures taken serve nothing.

U is the expected cost of the failures in a given period of pipeline exploitation.

The expected cost of failure corresponding to the service life of the pipeline is given by the expression:

$$U = C_U \omega_m(t) \tag{18}$$

Where C_U is the average cost of a failure in the suspect pipeline section.

$\omega_m(t)$ is the distribution density of the probabilities of times until the mth failure.

The Laplace transform of the expression (18) is of the form:

$$C_U \omega_m^*(\alpha) \tag{19}$$

Where $\omega_m^*(\alpha)$ is the Laplace transform of $\omega_m(t)$

The expression (19), after some elementary transformations, is given in the form:

$$U^* = C_U \omega_1^*(\alpha) [1 - \omega^*(\alpha)]^{-1} \tag{20}$$

Where

$$\omega^*(\alpha) = P_f \cdot f^*(\alpha) [1 - P_R f^*(\alpha)]^{-1} \tag{21}$$

Taking into account the expressions (10) to (21), the expression (18) is put into the form:

$$U^* = C_U P_f H^*(\alpha) \tag{22}$$

Where:

$$H^*(\alpha) = f^*(\alpha) [1 - f^*(\alpha)]^{-1} \tag{23}$$

For an exponential distribution of times between the failures caused by the compaction $f(t) = e^{-\lambda t}$, the inverse transformations of expressions (22) and (23) give:

$$H(t) = \lambda \text{ et } U = C_U \lambda P_f \tag{24}$$

Let Δt be the time interval between the entry of the conduit into service and the moment of apparition of the failures caused by the collapses for a projected service life of h years, we have:

$$C_p = C_k E_N \sum_{\Delta t=1}^h (1 + E_N)^{\Delta t-1} \tag{25}$$

And from expression (24), we have in this case:

$$U = \sum_{\Delta t=1}^h \frac{C_U}{(1 + E_N)^{\Delta t}} \lambda P_f \tag{26}$$

Taking into account expressions (17), (25) and (26), the optimization procedure in the case of the problem under investigation, consists in determining the probability PR which corresponds to the minimal value of the quantity M given by the expression:

$$M = \left[1 + \sum_{\Delta t=1}^h E_N (1 + E_N)^{\Delta t-1} \right] + \sum_{\Delta t=1}^h \frac{G}{(1 + E_N)^{\Delta t}} \lambda P_f \tag{27}$$

Where :

$$\begin{cases} M = \frac{C_T - C_0}{C_k} \\ G = \frac{C_U}{C_k} \end{cases} \tag{28}$$

RESULTS AND DISCUSSION

Case of the non-buried sections of the pipeline: To evaluate the precision of the reliability of the prediction of parameters λ_1 and λ_2 , the concepts of confidence interval corresponding to a confidence probability of 0.99 are used. The number of available statistical data collected from the follow up reports on pipelines laid in swampy grounds is very little and the recourse to the bootstrap method permits to construct new data samples^[15]. The confidence intervals of parameters λ_1 and λ_2 are deduced afterwards by the use of descriptive statistics. The results of the predictions are given in Table 1.

Table 1. Confidence intervals prediction

Diameter [mm]	Confidence Interval [10^{-3} 1/an]			
	λ_1^{inf}	λ_1^{sup}	λ_2^{inf}	λ_2^{sup}
1020	16,10	17,60	28,20	32,70
1220	21,90	23,80	33,90	36,50
1420	39,80	41,70	51,50	56,60

Table 2: The pipes' geometrical characteristics

D [mm]	F Cm ²	I Cm ⁴	W Cm ²	C (mm)
1020	442	5,6.106	1090	14

Table 3: Mechanical characteristics of the steel of the pipes considered^[13]:

\bar{R} N cm ⁻²	$\bar{R}_{1,0,2}$ N cm ⁻²	V_R	k_k	k_c	α 1/°C	qt Kg/cm
2,29.104	4,41.104	0,049	0,84	0,85	11.10-6	452

Table 4: Soil characteristics

γ_s N cm ⁻³	k_0 N cm ⁻³	K_U N cm ⁻³	ν cm ² s ⁻¹	τ_D N.s cm ⁻²	C N cm ⁻²
0,019	5	1,5	2,06.10 ³	4.10 ⁸	1,5

γ_s Soil specific weight, k_0 Compression soil strength modulus, K_U Shear soil strength modulus

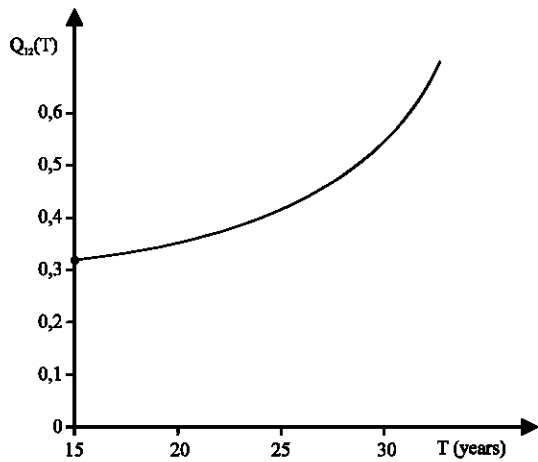

Fig. 6: Transition probability for S_1 to S_2

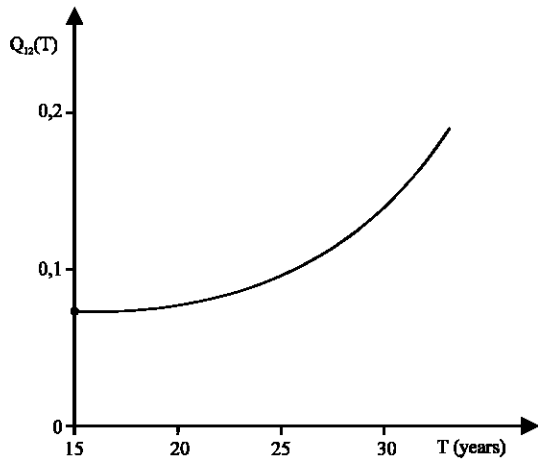

Fig. 7: Transition probability for S_2 to S_3

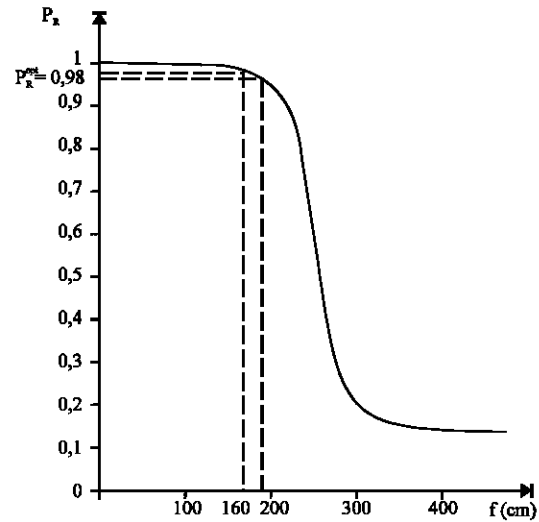

Fig. 8: Dynamics of the resistance reliability variation of the pipeline section considered in terms of the collapses evolution.

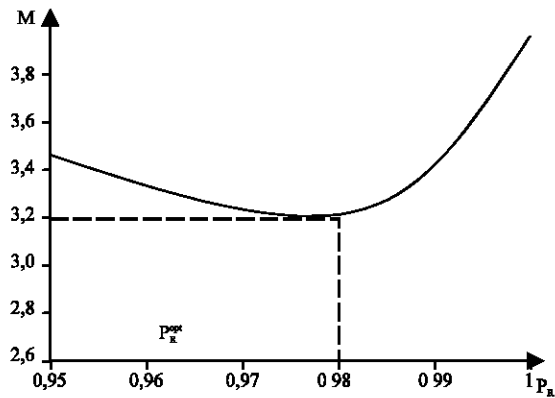

Fig. 9: Dependence of the cost criterion M on PR for $G=1,2$

Study of a concrete case of non-buried sections: The observations of the behaviour of 180 pipeline sections laid on swampy grounds, during ten years of exploitation have given the following results:

- The number of sections being still in state S_1 is 135
- The number of sections whose state has transited to S_3 is 36
- The number of failures and emergency repairs is 9

The reliability control of all of these pipeline sections consists in the determination of how many of the sections are still prone to change state up to the end of a given exploitation duration T. After data analysis the interval t_k is taken to be equal to three months and using the

approach shown in sections 2, the results of the prediction of state transition probabilities of the pipelines sections in terms of the duration T are shown in Fig. 6 and 7.

Case of a buried pipeline section: The pipeline section under consideration is 100 m long and subjected to an interval pressure of 50 bars, with $\Delta t = 50^\circ\text{C}$, $\lambda = 10^{-7}$ l Km h⁻¹. The section is initially rectilinear laid down on a weak soil periodically flooded. The starting data are given in Tables 2 to 4.

The use of the normal distribution for the study is justified for the strength variable R and for simplification purposes the transient load variable S is presented by a normal distribution. The considered pipeline section is subjected to loads which modify its shape. Depending on the level of compaction, we consider finite number of stress maxims in the dangerous sections Fig. 5. For each stress maxima (l) the safety state is defined by the safety domain $R_t > S$. The results of the calculation of dynamics of variations in the strength reliability of the pipeline section considered in terms of the compaction evolution are presented in Fig. 8. These results show, for predicted values of collapses over 190 cm, it is necessary to use constructive measures. The results of optimization calculations are shown graphically in Fig. 9. These results show how that the level of reliability is determined from the expression (28) for $M_{\min} = 3,2$ and $G = 1,2$. These measures should, in principle, limit the magnitudes of the compaction of f to lower values at 160 cm.

CONCLUSION

The reliability approach is first of all a tool which serves the calibration of the semi-probabilistic codes and the analysis of experience feed back. It constitutes a tool for decision making during conception and exploitation of master pipelines.

The cost of observations and of regular measurements of parameters affecting the stress state in pipes walls of pipelines does not represent any thing with respect to the spending and costs generated by a sudden rupture of the pipeline. On the other hand the follow up of the stabilisation state of the pipeline reduces significantly the exploitation spending. The measurement of the characteristics of a section of a pipeline, such as its position in the vertical plane, the temperature of the pipe walls during exploitation process is achievable. There exist some apparatus and control methods allowing situating with precision and rapidly the positions of the pipes. Captors placed 0.5 to 1 m apart, offer the possibility to follow regularity of the pipe wall temperature variations.

Finally, the analysis of the soil properties such as the porosity, the humidity, the consistence indices and others at each length of 100 or 200 m of a pipeline section actually presents no technical difficulty.

Pipelines destined for the transport of hydrocarbons must be designed and dimensioned so that to reach the objectives of safety and durability wanted. These objectives are not systematically reached by the mere respect of the existing rules and standards the reliability methods permit to do best and questions relative to soil/pipe interactions should occupy an important place.

REFERENCES

1. Melchers, R.E., 1999. Structural Reliability Analysis and Prediction, Ed. by Wiley and Sons, 2nd Edn.
2. Yen, B.C. and G.D. Tofani, 1985. Geometrical assessment of soil stress on pipeline coating, pipeline Ind- N° 5.
3. Cordary, D., 1994. Mécanique des sols, Ten et doc, Lavoisier
4. Cox, D., 1963. Renewal theory. John Wiley and Sons, New-York.
5. Barlow, R. and F. Proshan, 1964. Mathematical theory of Reliability.
6. Benjamin, J.R. and C.A. Cornell, 1970. Probability, Statistics and Decisions for Civil Engingeers, Marc Graw Hill, New-York.
7. Holtz, R. and W. Kowas, 1994. Introduction à la Géotechnique, Ed. L. P. M, Tech et Dec.
8. Peignaud, M., 1972. Consolidation sans charge variable, tassement et pression interstitielle, Annales de l' I I B TP, série sols et fondations, N° 85.
9. Girous, J.P., 1975. Tassement et stabilité des fondations Superficielles, P.U. G de Grenoble, Grenoble
10. Cassan, M., 1978. Les essais in situ en mécanique des sols, Eyrolles-Paris.
11. Bouzid, R. and Co., 2004. Approche physico-statistique à l'étude de la fiabilité des gazoducs, 23^{èmes} journées de printemps, Fiap Jean Monnet, Paris.
12. Lemaitre, J. and J.L. Chaboche, 1980. Mécanique des matériaux, Ed. Dunod, 2^{ème} Edn.
13. Abdelbaki, N. and Co., 2004. Statistical approach to the analysis of the strength of pipes used in gazoducs, CHISA, Prague.
14. Enevoldsen, I. and J.D. Sorensen, 1995. Reliability based on optimization in structural engineering, Structural Safety Elsevier-N° 15.
15. Efron, B., 1973. Bootstrap methods: anoder look at the jackknife, ann. Statist, 7: 1-26.